

THE
TRIUMPH
MAYFLOWER
CLUB

MAYFLOWER OVERHAUL, RECONDITION, MAINTAIN

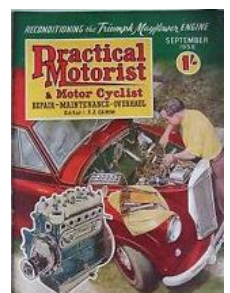
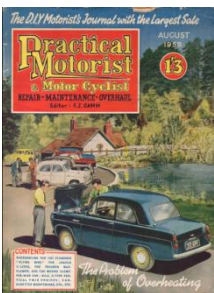
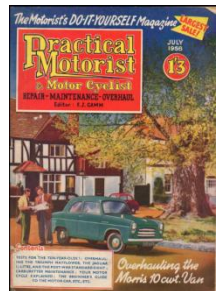

March 2018 | Paul Burgess

Contents

Overhauling the Triumph Mayflower	Practical Motorist & Motor Cyclist, June 1958	2
To Set Ignition Timing		2
To Set Valve Tappets		3
To set Valve Timing		3
Distributor & Oil Pump Drive Shaft		4
The Oil Pump		4
Pistons		5
Connecting Rods and Big End Bearings		5
Main Bearings and Thrust Washers		5
The Clutch		6
The Gearbox		6
Overhauling the Triumph Mayflower	Practical Motorist & Motor Cyclist, July 1958	8
To Remove Front Suspension Unit		9
Steering Gear		10
To Remove and Refit Steering Wheel		10
Rear Axle		12
Brakes		13
Overhauling the Triumph Mayflower	Practical Motorist & Motor Cyclist, August 1958	
14		
Brakes (cont.)		14
Petrol Pump		15
Carburettor		16
Reconditioning the Mayflower Engine	Practical Motorist & Motor Cyclist, Sept 1955	18
Lubrication & Ventilation System		18
Cooling System		19
Ignition System		19
Top Dismantling		19
Valves and Springs		20
Engine Removal & Dismantling		21
Connecting Rods & Pistons		21
Main & Camshaft Bearings		22
Oil & Water Pump		23
Timing		23
Clutch		24
Maintaining a Mayflower	Car Mechanics, February 1960	25

Overhauling the Triumph Mayflower

Practical Motorist & Motor Cyclist June 1958

Setting the Ignition Timing and Valve Tappets. Removing the Distributor and Oil Pump Driving Shaft and Checking Pistons and Connecting Rods

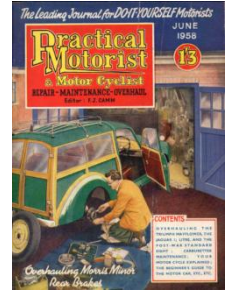

THIS car is fitted with a four-cylinder engine, which has a cylinder bore of 63 mm. and a stroke of 100mm., with a cubic capacity of 1,247 cu. cms. A compression ratio of 6.8 is employed.

The crankshaft is accommodated in three precision type, white metal lined, steel-backed bearings. Crankshaft thrust is taken by two steel-backed white metal covered half washers, which fit into a recess machined on each side of the rear bearing cap.

Side by side valves are used and are operated by flat-based chilled cast-iron tappets, which bear directly on the camshaft. With early batches of engines a special cast iron alloy was used in the manufacture of the camshaft, but all subsequent engines are fitted with a case-hardened steel camshaft. The camshaft is provided with four journals which are mounted directly in the cylinder block. The camshaft is located endwise by a case-hardened steel plate which also accommodates end thrust.

The chilled cast-iron tappets are accommodated in cast-iron guide blocks, which are secured by four bolts to the cylinder block. The centre pair of bolts also secure the distributor and oil pump drive shaft abutment, and for this reason are longer than the outer ones.

The oil pump is of the submerged double rotor type and driven by a vertical shaft on which is pegged a helical gear, an integral portion of which forms the cam for operation of the petrol pump. The helical gear on this shaft is driven by a similar gear which is cut on the camshaft.

To Set Ignition Timing

There may be occasions where, a new distributor has to be fitted or the helical drive gears are dis-engaged inadvertently. In such cases proceed as follows:

Place No.1 piston on T.D.C. of its compression stroke (i.e., with both valves closed). T.D.C. for Nos. 1 and 4 cylinders is indicated by the alignment of the pointer on the timing cover with the hole in the crankshaft fan pulley, as shown in Fig. 1.

Where the distributor driving shaft is correctly fitted, and the helical gears are appropriately engaged, the offset slot at its upper extremity will be as shown in Fig. 2 with the engine in this position, i.e., T.D.C. of compression stroke for No. 1 cylinder.

It is now necessary to fit the distributor in its correct position for ignition, which should occur 2 deg. before T.D.C. To do this first set the Advance/Retard plate one division on the scale toward "R" . Assemble the distributor on the cylinder head with its clamping bolt slack.

The distributor body should now be rotated in a clockwise direction until the points, which should have been already set to the correct gap of 0.010in. to 0.012in., are just commencing to separate. It is now merely a question of tightening the clamping bolt and afterwards advancing the adjuster one division until the pointer is aligned with the central or neutral marking, i.e., the ignition will then be

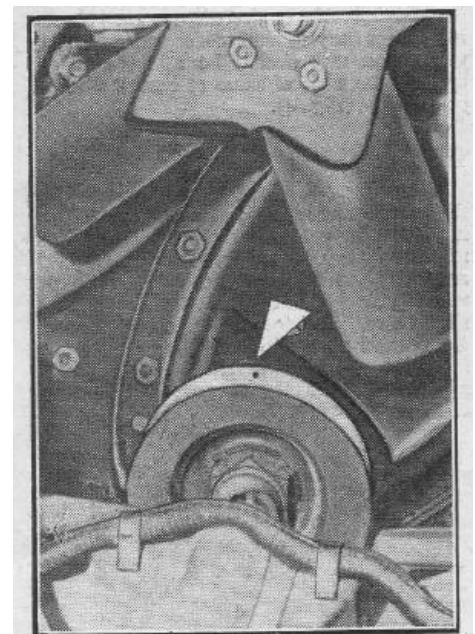

Fig. 1.—T.D.C. of Nos. 1 and 4 pistons

occurring 2 deg. B.T.D.C. The car should then be taken on the road and ignition set to just pink at 30 m.p.h. under light load, whilst using regular (Pool) petrol.

Where the distributor oil pump helical gears are disengaged for any reason it is merely a question of reengaging by trial and error (with the engine on T.D.C. of No. 1's compression stroke) until the offset slot at the upper end of the drive shaft assumes the position shown in Fig 2

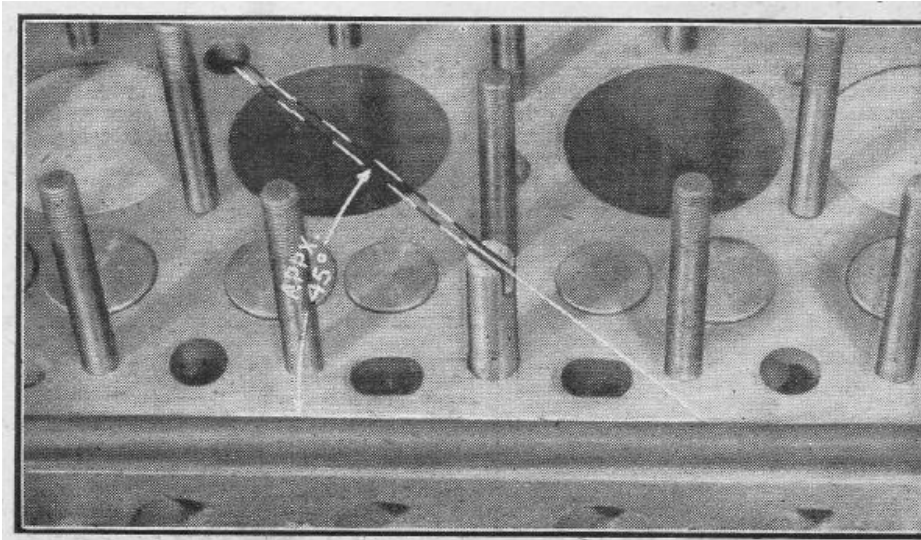

Fig. 2.—Position of offset and slot at upper end of distributor driver shaft with No. 1. cylinder at firing point.

To Set Valve Tappets

Turn engine until No. 8 valve (the rearmost one) is fully open and then set No. 1 valve (front one), the tappet for which will be on the back of its cam, or its concentric position. Set tappet for No. 1 valve to 0.015in. Continue to turn engine until No. 7 valve is fully open and adjust clearance for No. 2 valve. Continue in this way setting the rear valves fully open and set clearance on one of

the front valves so that the number of the two valves total "9". Thus 8 and 1, 7 and 2, 6 and 3, 5 and 4, 4 and 5, 3 and 6, 2 and 7, and finally with No. 1 valve fully open set clearance on No. 8 valve.

There are two methods of actually adjusting the clearances – first by using three spanners with different size jaws, viz. 1/2in. A/F for lock nut, 13/32in. A/F for flats on tappet and 7/16in. A/F for adjuster screw. The second method disposes of the 13/32in. A/F spanner for the tappet flats and employs a wedge between the two adjacent tappets as shown in Fig. 3.

To Set Valve Timing

Where timing gears are marked, on the assumption that the engine is in a dismantled condition, the following procedure should be used:

When the crankshaft and camshaft timing gears have been aligned, fore and aft, with a straight-edge, fitting or removing shims from under the crankshaft gear until these are in the same plane, the crankshaft gear can be fitted and this gear and the loose camshaft gear should next be encircled with the timing chain and the latter gear offered up to its spigot on the camshaft, by trial and error, until the scribed

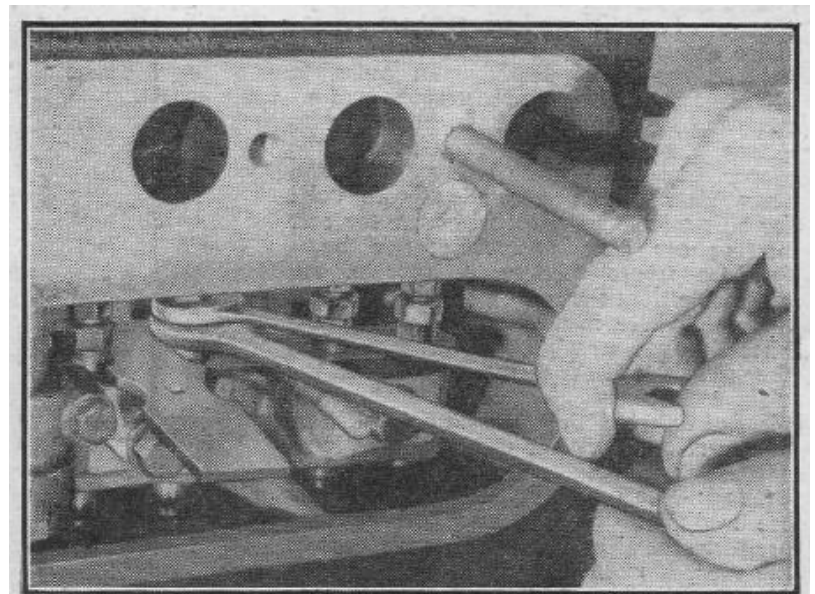

Fig. 3.—Setting tappets utilising two spanners and taper wedge.

markings shown in Fig. 4 are matched and the cut-away in camshaft is as shown. The alternative pair of set-screw holes in the camshaft gear provide a half-tooth variation in timing. Turning the camshaft gear back to front, from any position, gives a quarter-tooth adjustment, whereas the use of the second pair of holes in this reversed condition allows a three-quarter-tooth variation from the original position.

It is important when matching these markings that the driving side of the timing chain is kept tight and that neither the camshaft nor crankshaft are moved.

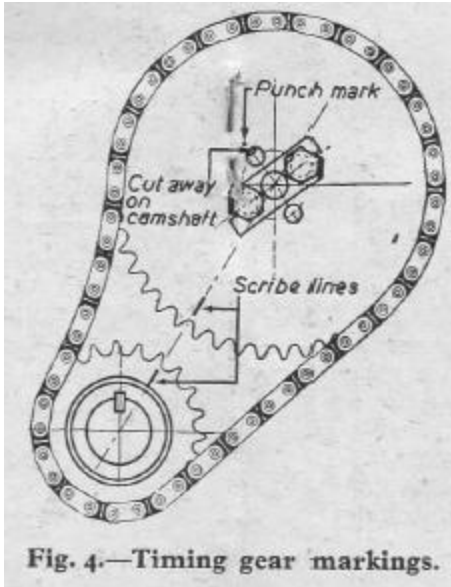

Fig. 4.—Timing gear markings.

Having matched the timing markings and rechecked these, whilst holding the timing chain tight, the set-screws can be tightened and the locking plate engaged with the flats on the hexagonal heads.

Distributor and Oil Pump Drive Shaft

The oil pump and distributor are driven by a single vertical shaft. The shaft runs in a flanged bush, which is pressed into the cylinder block at the bottom of the tappet chamber.

The spiral gear is integral with a cam which actuates the petrol pump by means of a short rod. The gear is located on the vertical shaft by a pin, which is retained by a clip (see fig. 6).

To Remove Distributor and Oil Pump Driving Shaft

Remove distributor assembly after disconnecting the electrical leads from the sparking plugs and the coil and removing the two securing nuts and spring washers. Detach tappet cover and packing after removal of the two domed securing sleeves. Withdraw the two set-screws which secure the outer abutment bracket to the

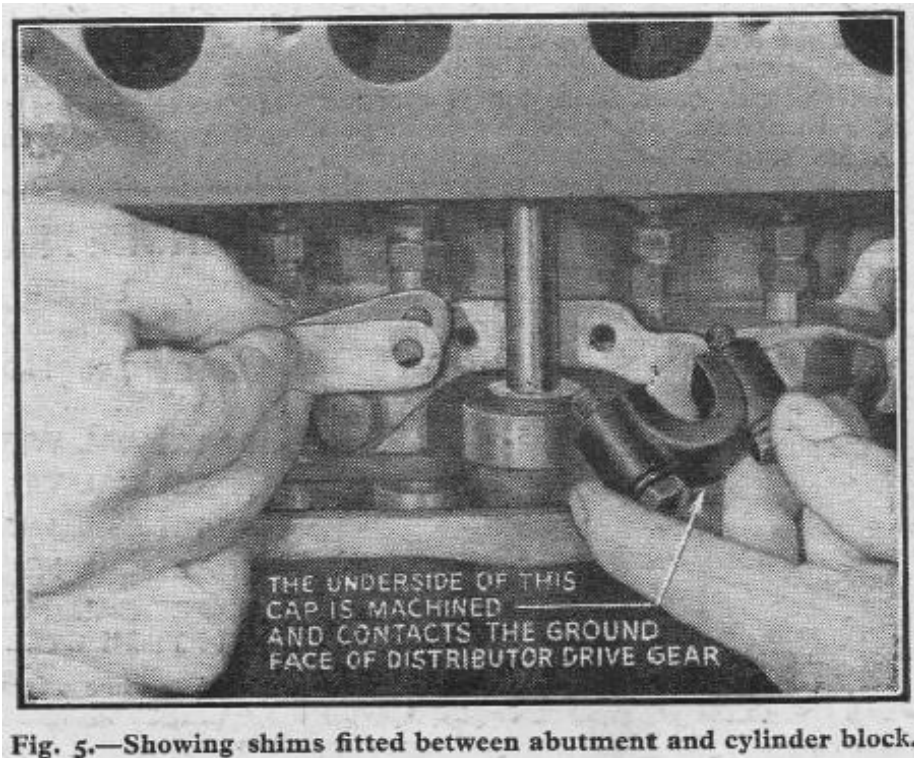

Fig. 5.—Showing shims fitted between abutment and cylinder block.

inner one and remove the latter bracket. Take care not to drop the packing shims into the sump (see Fig. 5). Remove the two bolts which secure the main abutment bracket and inner ends of the two tappet guide blocks to the cylinder block. Withdraw main abutment bracket. Remove petrol pump and withdraw operating spindle. Remove the driving pin retaining clip (see Fig. 6) and withdraw pin. The driving shaft can now be lifted out of the engine.

The Oil Pump

The pump is of the double-rotor type and provides much more oil than is actually required, and little wear is likely to be experienced during the normal life of the car.

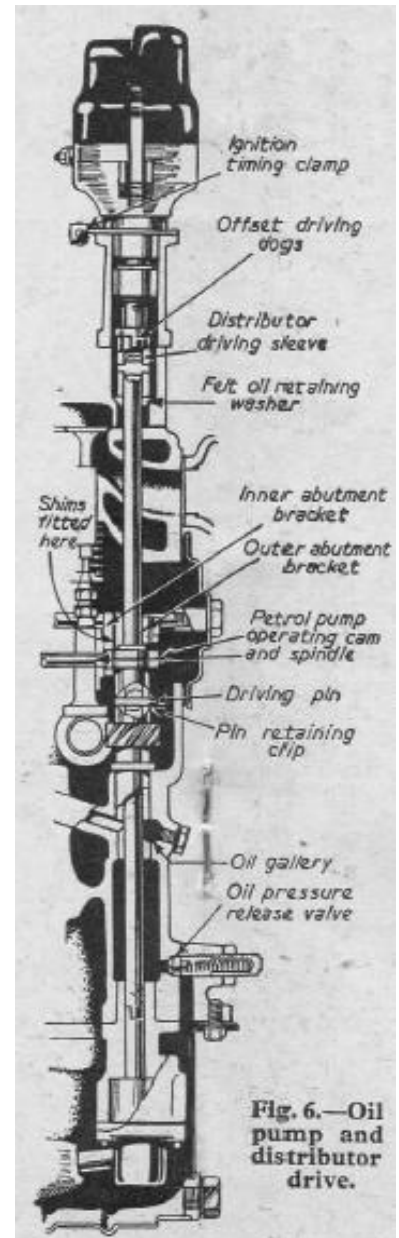

Fig. 6.—Oil pump and distributor drive.

The only possible attention, apart from collapse due to a defective part, which is not likely until some 200,000 miles have been covered, will be the elimination of end float in the rotors. This can be met by lapping the joint faces on the rotor casing and cover assembly.

If it is required to remove the oil pump for any reason it is merely necessary to withdraw the sump and to remove three nuts.

Pistons

The pistons are of aluminium alloy and are provided with a split skirt; this split must be fitted towards the camshaft side of the engine.

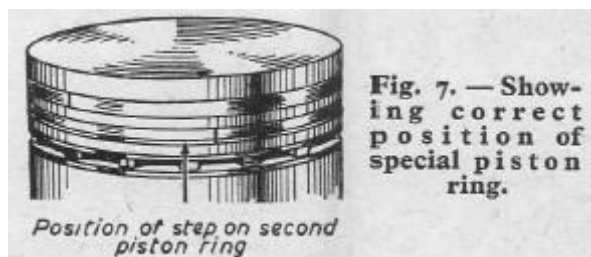

Two compression rings are fitted, the lower one of these being tapered (see Fig.7). The tapered ring must be fitted with the larger diameter downwards. The correct fitting position is identified by the etching of a "T" on the upper face of the ring. The compression rings fitted to a very few early cars were of the parallel type.

Selective assembly of pistons was employed in the factory, three piston sizes being used, viz.: "F" (small), "G" (mean), and "H" (large), the sizes varying by 0.0004in. The bore sizes for these three sizes of pistons are: —

"F"	"G"	"H"
2.4799in.	2.4803in.	2.4807in.
2.4802in.	2.4806in.	2.4810in.

Where cylinder bore wear exceeds 0.007in. and 0.005in. at top and bottom of the bores respectively, a rebore is necessary if a satisfactory repair is to be obtained. Oversize pistons, normally available from the factory through local dealers, are

+0.020in., +0.030in. and 0.040in. Selective assembly is not used with such pistons.

When it is necessary to exchange a piston this only entails the removal of the sump, the withdrawal of the bearing cap, noting the offsetting of the connecting rods and the markings on these components for reassembly.

Connecting Rods and Big End Bearings

The connecting rods are offset as shown in Fig. 8, and have nominal centres of 7 ¼ in. Precision type bearings are fitted and *no hand scraping* of these is permissible.

The standard crankpin size is 1.750in., 1.7495in. Where undersized bearings are fitted their sizes are stamped on the back of the shells. The standard undersize bearings obtainable from the factory are - 0.020in., 0.030in. and 0.040in. Where crankpin wear exceeds 0.002in., regrinding of the crankshaft is required if a satisfactory repair is to be effected.

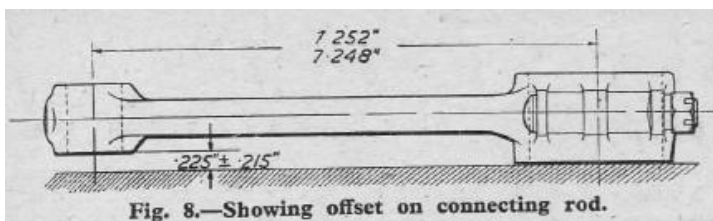

Main Bearings and Thrust Washers

Whilst it is possible, to exchange the centre main bearing fairly easily without removal of the engine unit, the removal of the front and rear bearings can best be effected after removal of the engine owing to the necessity to remove the sealing blocks, etc.

The normal end float of the crankshaft is 0.004in. to 0.006in., and where these dimensions are seriously exceeded new thrust washers should be fitted. In order to exchange these thrust washers, as well as removing the engine, it is necessary to detach the gearbox as a unit; remove the rear sealing block, which is secured by two screwdriver slotted screws and two bolts for oil retainer, and then withdraw the rear bearing cap after unscrewing two bolts. Oversize thrust washers + 0.005in. are obtainable from the factory through the local dealer. Where insufficient end float exists after fitting a

new pair of thrust washers, the steel sides of the thrust washers, i.e., the plain side, should be rubbed down on a piece of emery cloth placed on a flat surface.

The standard size of the crankshaft journals is 2.0000in., 1.9995in. Undersized bearings - 0.020in., -0.030in. and - 0.040in. are available. Where undersized bearings are fitted the size is stamped on the back of the shell. If worn clearance exceeds 0.006in. (dry), regrinding of the shaft is necessary if a satisfactory repair is to be expected.

The Clutch

The clutch (see Fig. 9) is of the single dry-plate type, consisting of a driving plate assembly splined to the gearbox constant pinion shaft's forward extension; a cover assembly and a release bearing which is operated by a fork mounted on the clutch cross shaft.

As wear occurs to the friction facings (A), the outer ends of the release levers (B) will move with the pressure plate (C) closer to the flywheel, and the inner ends of these levers will move outwards with the release lever plate (D) thus reducing the clearance between (D) and (E). It will be understood, therefore, that as this necessary clearance of 1/16in. (.0625in.) is reduced by wear it is necessary to restore it by suitable adjustment of the fork which carries the release bearing carrier. This is effected by alteration of the adjusting nuts shown in Fig. 10.

There is obviously a limit as to the wear which this service adjustment can accommodate and when this limit is reached it will be necessary to replace the centre, or driven plate, assembly. The fitting of new friction facings to the driven plate is not recommended. The exchange of the centre plate assembly entails the removal of the gearbox unit and the withdrawal of the cover assembly. The removal of the gearbox is covered later in this article when dealing with that unit. When removing the clutch the holding screws should be slackened off a turn or two at a time to allow

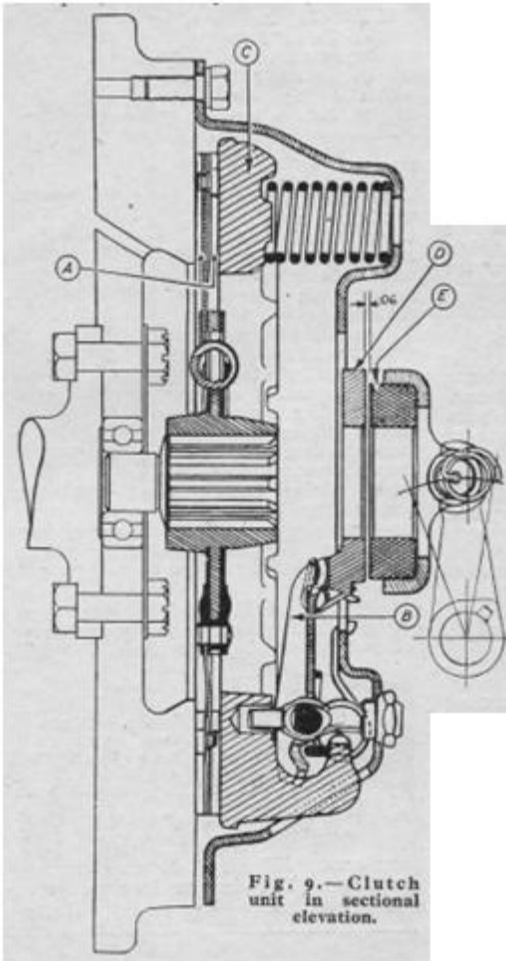

Fig. 9.—Clutch unit in sectional elevation.

for the extension of the thrust springs.

After exchange of the centre plate, which does not require any alteration to the clutch cover assembly, nor, indeed, must such be attempted, it is merely necessary to adjust the four nuts shown in Fig. 10, until there is an inch of free movement at the pedal pad, which represents the necessary 1/16in. clearance between (D) and (E) (see Fig. 9).

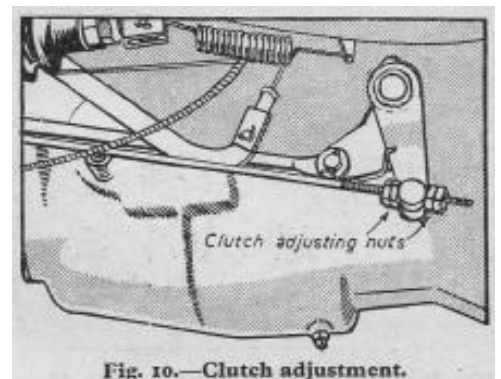

Fig. 10.—Clutch adjustment.

Setting Release Levers

This should only be required when it is found necessary to renew any parts in the cover assembly, or a complete clutch overhaul is required. It will be found more satisfactory to obtain a reconditioned clutch in exchange for the one at present fitted.

The Gearbox

A gearbox having three forward gears and reverse is fitted. Synchro-mesh is provided on the three forward gears.

To remove the gearbox as a single unit proceed as follows:

Disconnect battery lead. Disconnect clutch coupling rods from housing by removal of the split pinned nut, which secures the trunnion to operating lever in the clutch operating cross shaft, and the split pin and plain washer which secures a second rod to the fixed bracket on the housing. Disconnect the two transverse gear operating cross shafts from the selector shafts by removal of two bolts and self-locking nuts. Remove propeller shaft after withdrawal of the four bolts and self-locking nuts, which secure the rear universal coupling to the driving flange on the rear axle. Remove centre steering tie-rod after slackening the lock nuts and screwing rod out of sockets. Detach exhaust downtake pipe from manifold afterwards placing lifting jack under engine sump using a wood packing to prevent damage. Remove nuts and bolts which secure housing to engine. Having detached petrol pipe clip from detachable cross-member, remove the two self-locking nuts which secure the rear of the engine to this member. After ensuring that the jack is taking the weight off the rear cross-member, remove the two bolts by which it is attached to the chassis frame and withdraw.

Lower the engine on the jack, just sufficiently to enable the clutch housing to clear the toe board, pressing as it is drawn back to disengage the constant pinion shaft from the clutch assembly. The necessity to lower the rear of the engine is the reason for removal of the steering Centre rod.

Reassembly requires approximately the reverse procedure to that described above for removal. Where it is necessary to remove the clutch for any reason, or where the centre plate is moved relative

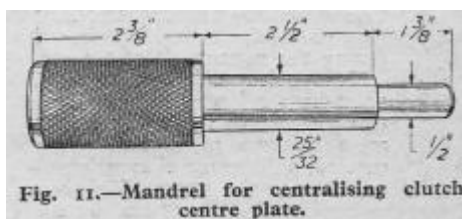

to the cover assembly when withdrawing the unit, it will be necessary to centralise it before offering up the gearbox with a suitable mandrel. Fig. 11 gives the dimensions of a suitable mandrel. A mandrel can be made less elaborately from wood, provided the two smaller diameters are as given, to fit into the splined centre of the clutch and the bush in the end of the crankshaft.

To Dismantle Gearbox

Having removed the unit from the car proceed as follows:

Detach the top cover, withdraw the clutch operating shaft after removal of locating bolts and actuating fork. Remove the taper set screw from the side of the casing (R.H. side for R.H.S. Models), which secures the selector rod. Withdraw the selector locking plungers after extracting the split pin located screws. Screw out speedometer drive securing set screw and pull out gear. Remove gearbox extension and paper packing after withdrawal of six securing bolts. Tap out the selector rod from the rear of casing after first removing the wired stop screw.

Remove the countershaft and reverse pinion locating bolt and after withdrawal of the countershaft front cover (located by two wired set screws), tap the countershaft out with a suitable length of tube (0.787in. outside diameter X 5 3/4 in. length), leaving the tube in the- countershaft gear to retain the 48 needle rollers fitted.

(To be continued)

Overhauling the Triumph Mayflower

Practical Motorist & Motor Cyclist July 1958

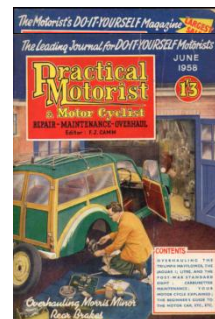

Continuation of Details of Dismantling and Reassembling the Gearbox, and Instructions for Maintaining the Steering

WHILE removing the countershaft and reverse pinion locating bolt, as described last month under dismantling the gearbox, it is important to maintain contact between the tube and countershaft during this operation. The removal of the countershaft will allow the countershaft gear cluster to fall to the bottom of the casing with the tube retaining the rollers.

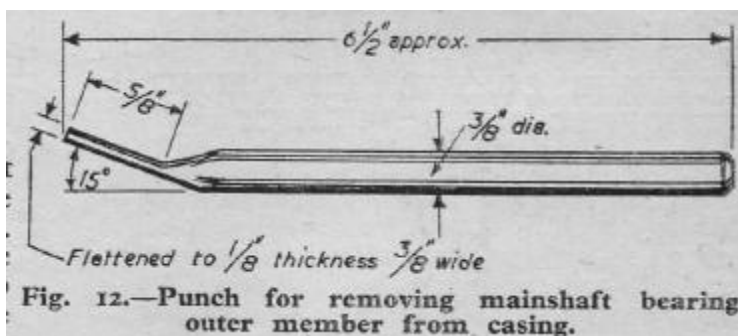

Remove the gearbox front cover after withdrawal of four wired set screws. Note that these set screws are each provided with a plain and spring washer and between the casing and each plain washer a coil of lead wire is fitted to prevent oil leakage. Tap out the constant pinion ball bearing, utilising a suitably cranked drift, such as is shown in Fig. 12.

Unless it is necessary to renew the constant pinion or its bearing, it is unnecessary further to dismantle this unit. If it is necessary for either of these reasons to dismantle the assembly, the small circlip must be removed with the washer utilising a suitable pair of circlip pliers.

Tap the mainshaft rearward in the casing with a suitable soft metal drift, as shown in Fig. 13, until the rear bearing is free of the casing. The mainshaft can now be tilted, and the "Second" and "Top" synchro unit removed. Note the position of the shorter boss on the hub of the latter towards the rear of the unit for reassembly.

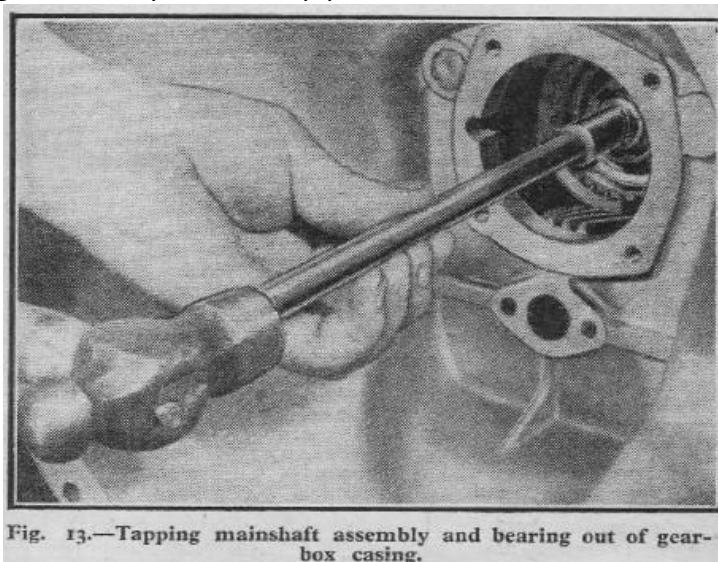

The further dismantling of the mainshaft gear requires the removal of the mainshaft circlip, which at the dealers, will be carried out with a special extractor. In the absence of this extractor the circlip can be severed by a sharp blow with a cold chisel and the use of a strong pair of pliers.

The mainshaft gears can now be removed and the shaft withdrawn. Reference to Fig. 14 will assist in their being assembled in their proper sequence when the unit is built up again.

The countershaft assembly can now be lifted out of the casing with the retainer tube still holding the needle rollers in position. The thrust washers (one at each end of cluster), the larger one at the front and the smaller one at the rear, can now be removed.

Tap out the reverse pinion spindle through the rear of the casing, the locating bolt which also passes through the countershaft having already been removed. This frees the reverse pinion for withdrawal, which it should be noted has its reduced portion towards the front of the unit. Lay aside the two phosphor bronze thrust washers for refitting, or replacement, according to their condition.

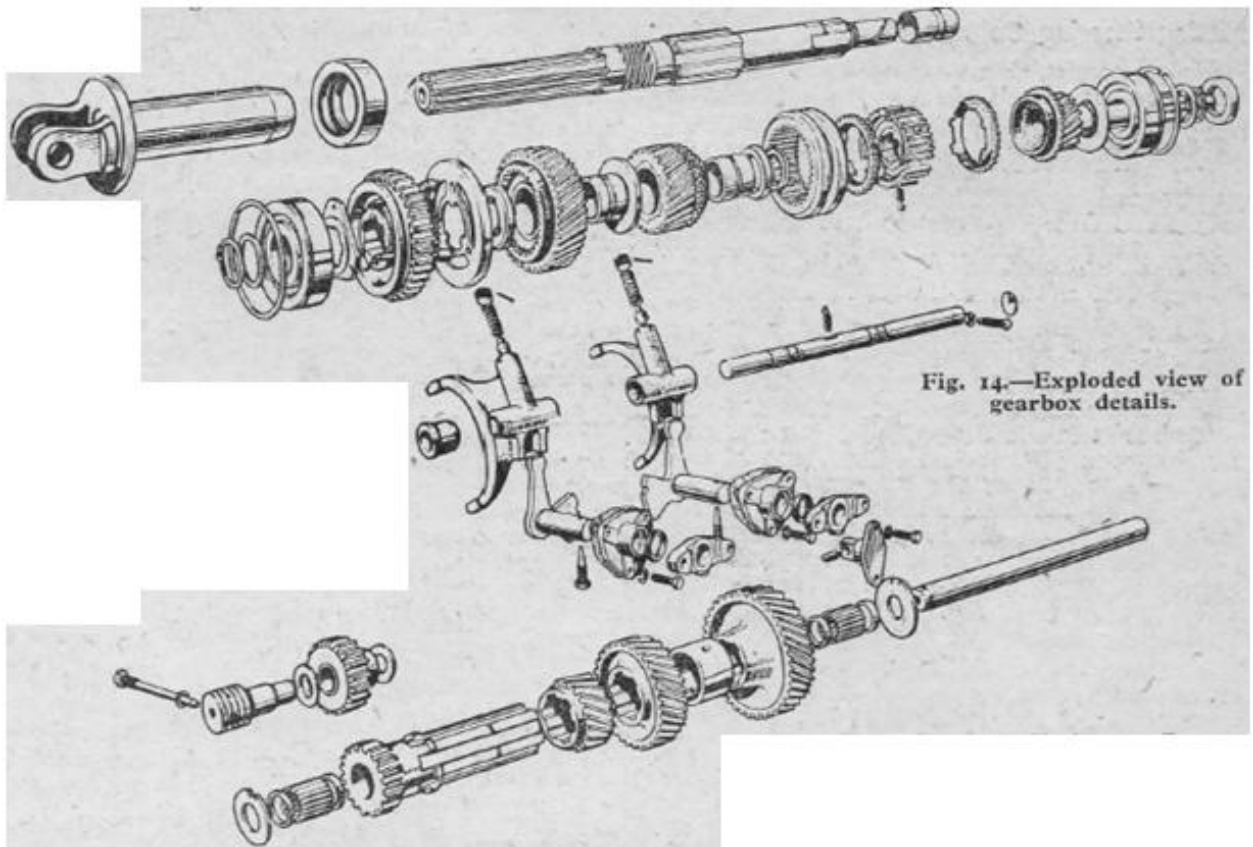

Fig. 14.—Exploded view of gearbox details.

Reassembly of Unit

Reassembly of the unit will be carried out by adopting an approximately reverse procedure to that described above for dismantling, noting the following points for particular attention:

Reassemble the countershaft gears noting the position of these, shown in Fig. 14. Ensure that the 48 needle rollers are in position—24 at each end—and locate these with grease whilst entering retainer tube, if this has been removed.

Position front countershaft thrust washer (the larger of the two) with the tip of the countershaft. The smaller thrust washer can be located with grease. The countershaft gear cluster should be assembled with the countershaft in position temporarily; to check end float, which should be between 0.006in. to 0.010in., if end float is excessive fit new thrust washers. Where the ball bearing has to be replaced first locate the baulk pin washer on its splines and then press on ball bearing.

Where synchronisation has been unsatisfactory on the "Second" and "Top" gears the condition of the coned faces in the synchro hub and on its mating gears should be ensured and if necessary should be lapped together with fine carborundum powder. Similarly the condition of the six synchro springs should be satisfactory. An axial load of 19lb. to 21lb. is specified at the works, but involves the use of elaborate equipment. The use of a spring balance can be employed, or alternatively this will have to be judged by manual means, as is normally done in the average garage.

To Remove Front Suspension Unit

Jack up front of car, remove road wheel and place support under jacking bracket and withdraw jack. Disconnect steering outer tie-rod from the steering lever and compress front spring by use of a lifting jack under brake drum. Remove locking nut on upper end of the shock absorber whilst holding the larger nut with a suitable 1 ¼ in. A/F spanner. Remove the four nuts on the studs which secure the bottom of the damper and withdraw unit from below.

Withdraw the split pins which secure the six spring pin bolt nuts and remove the centre bolt on each side and replace with guide pins as shown in Fig. 15 and leave the other four for later withdrawal.

Remove jack from under brake drum and insert under centre of spring with a suitable wood packing to provide clearance for the four shock absorber mounting studs. Withdraw the four spring pan

securing bolts not so far withdrawn and lower jack, thus releasing spring pan. All but very early cars are provided with a rebound cable, which is attached to a special bolt which is substituted for the front outer spring pan securing bolt.

Disconnect the brake hose from the body valance. Under no circumstances should an attempt be made to turn the hose by its hexagonal extremities as this will damage the hoses. The withdrawal of four bolts which secure the top inner fulcrum bracket completes the removal of the unit.

Reassembly of the front suspension involves the reverse procedure to that described above, with the additional necessity to "bleed" the hydraulic system after reassembly.

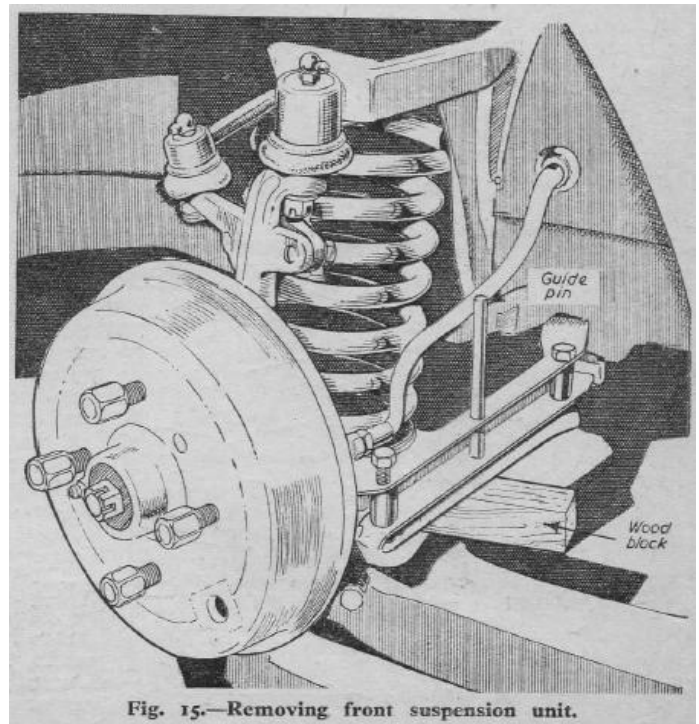

Steering Gear

The steering gear is the bishop's cam and lever Model T, which has a ratio of 11 to 1. The rocker shaft runs directly in the steering box as shown in Fig. 16 . A lever integral with this shaft carries a peg which engages with the cam groove but does not touch the bottom of the groove. Adjustment for wear is effected by varying the depth of engagement. This adjustment is carried out by means of set screw, Fig. 16, in the top cover of the steering box.

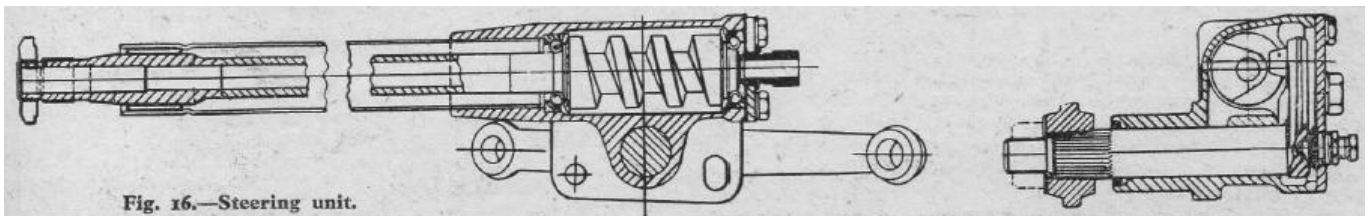

Maintenance of Unit

An oil filler plug is provided in the steering box lid. A high pressure oil should be used, and under no circumstances should grease be used.

The top bush in the steering column is impregnated with graphite and should not require lubrication. If, however, after many miles of service a squeak develops, this can be cured by sparing application of oil.

Check that the steering drop arm and ball joints are tight and likewise the bolts securing the steering bracket to the frame.

To Remove and Refit Steering Wheel

Disconnect the electrical leads from the snap connectors at the base of the steering column, noting the terminals to which each cable is connected. Slacken off nut on live clamping at the base of the steering box. Catch escaping oil in a receptacle. Loosen the three grub screws in the steering wheel and withdraw stator tube and trafficator control.

Unscrew the nut securing the steering wheel before removing the steering wheel, the splined hub and the splines on the centre column should be marked with a centre punch to ensure similar relation after refitting. This correct relation is necessary so that the self-cancelling slots will be correctly positioned.

Remedies for Various Difficulties

Easy steering with excessive backlash or knock- can be remedied as follows:

Disconnect the tie-rods from the drop arm (Fig. 16) and set steering on partial lock (not full lock). Grip the lever firmly and try to move it backwards and forwards, whilst preventing the steering wheel from moving, and watch for lift on the wheel. If such end float exists it is due to lift of the cam on the ball bearings.

The remedy for this complaint is to remove one or more shims from the end cover a very slight preloading of the bearing balls is permissible.

Bent Steering Column

Whilst slight pulling to one side has little effect on the feel of the gear, a badly bent column, which is causing stiffness, must either be rectified, if this is possible, or alternatively replaced.

Tight Cam Bearings

If an improvement is effected by releasing the four end cover set screws insert an additional shim or shims as necessary to ease steering. End play must not exceed 0.0015in. Take care to replace ball cage properly if this comes away when fitting the extra shims and always renew the paper packing if its condition is suspect, otherwise oil leakage may develop.

Fitting Steering Column Controls

Under normal circumstances when it is necessary to remove the steering column controls for any reason the best procedure to adopt is to mark the position of the control brackets on the steering outer column, and it will thus only be necessary to position these brackets so as to permit free movement of control rod in the vertical plane.

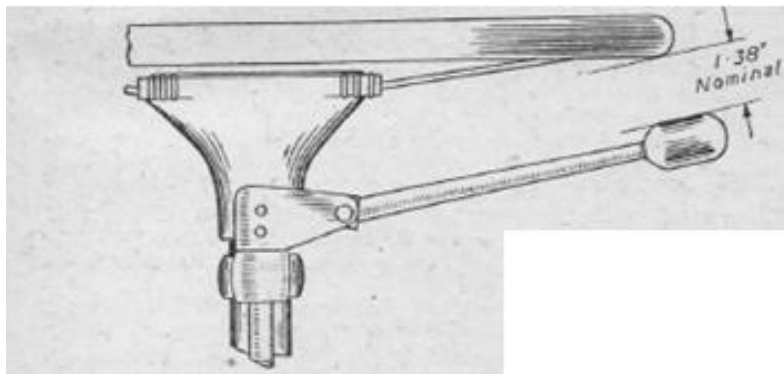

When new controls or a steering unit has to be fitted the following procedure is recommended:

Offer up the controls to the steering column and with the upper bracket and the control shaft in the same vertical plane as the drop arm pivot, adjust the position of the upper bracket on the steering column so that, with the knob on the hand lever forced upward as far as it

will go, the upper side of the knob is approximately 1 3/8in. from the underside of the steering wheel, as shown in Fig. 17. Secure this bracket in this position.

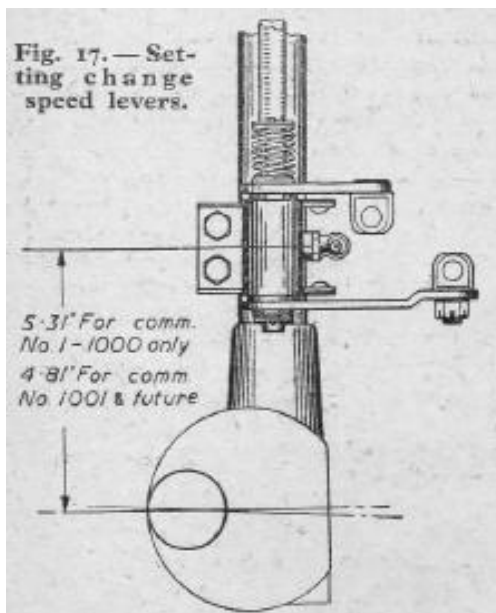

The positioning of the upper bracket automatically forces the distance of the lower bracket up the steering column. If being necessary to align it in the same vertical plane as the upper bracket and hence with the drop arm pivot.

After placing the gearbox in "neutral" and with the connecting rods attached to the two operating cross-shafts, place the hand lever at the top of the steering column in a horizontal position and connect the upper ends of connecting rods on their respective levers on the steering column. Adjust the position of the nut on each side of the trunnion attachment on the respective levers as necessary to maintain the horizontal position of the lever (the neutral position) with complete freedom of movement of the control shaft upwards and downwards.

The final proof of the setting of these controls should be ensured by a road test.

Rear Axle

The rear axle is of the hypoid type with semi-floating half-shafts which are mounted on ball bearings accommodated in the axle casing and located endwise against a flange on each shaft by a bearing housing. The bearing housings are each secured with their respective brake back plate to the flanged end of the axle sleeves.

The hypoid pinion is housed in the centre casing being mounted on inner and outer opposed taper roller bearings. The outer race of the inner bearing is adjustable fore and aft by shims fitted between it and the abutment face in the casing.

The hypoid pinion's forward bearing is separated from the inner portion of the outer bearing by the interposition of a distance piece and shims. The shims enable the bearing preload to be adjusted.

Oil sealing is provided in the case of the wheel bearings by a super oil-seal which is fitted in the outer end of the bearing housing and, as far as the nose piece of the centre casing is concerned, a special seal assembly is pressed into the casing. A detachable breather valve screwed into the left-hand side of the casing prevents the build up of excessive pressure.

To Remove and Dismantle Half-shafts, Etc.

Jack up rear of car and remove wheels. Remove brake drums after withdrawal of two countersunk screws. Disconnect brake hydraulic connection at brake backing plate and handbrake lever operating cable. Remove the four bolts and nuts, which secure the brake backing plate and bearing housing to the axle sleeve.

Withdraw half-shaft and remove hub after removing the castellated nut, washer and taper collar. (If a hub extractor is available this will be used before withdrawal of bearing housing and brake backing plate bolts.)

The removal of the rear hub will release the bearing housing and oil seal. The oil seal can be driven out and replaced with a suitable diameter tubular drift—the lipped portion of the seal should fit inwards against the ball bearing. If it is wished to replace the ball bearing it may be removed on a suitable press.

To Remove Rear Axle From Chassis

Jack up rear of chassis frame and fit a support under each rear jacking bracket. Take weight of rear axle on a jack and remove nut from bottom eye of each shock absorber and remove two rubber bushings from respective eyes of these absorbers and separate them from their mountings. The weight must be taken off these absorbers when carrying out this operation. Disconnect propeller shaft from flange on pinion. Separate handbrake lever from compensator at rear of axle and free cable from its abutment by removal of pinch bolt.

Disconnect hydraulic brake pipe from its attachment to rear axle by detaching the two pipes from the "T" shaped adaptor union on the axle and freeing this adaptor from the axle bracket by removal of attachment bolt, thus leaving the adaptor attached to the flexible lead. Catch brake fluid in container when carrying out this operation.

Finally remove the self-locking nuts from the "U" bolts securing the shock absorber/spring plates and lift out the rear axle assembly.

Dismantling and Reassembling Rear Axle

Owners are not recommended to attempt to strip the rear axle as this necessitates the use of a reasonable amount of expensive equipment including extractors and setting fixture. The best course to adopt where it is necessary to replace any gears or bearings is to refer the repair to the local Triumph dealer, who may well advise the installation of a factory-reconditioned unit.

Repairs and Adjustments

Where oil leakage occurs, reference should be made to the following:

1. *Leakage Round Rear Cover Plate.*— Poorly fitting cover plate due to loose bolts or distortion, possibly caused by incorrect location of jack when raising the rear of the car.

2. *Oil Leakage from Front of Pinion Housing.*—Defective oil seal, breather valve blocked, incorrect grade of oil or too high an oil level employed. Before the seal can be changed it will be necessary to detach the propeller shaft from the driving flange and to remove this flange.
3. *Loss of Oil Leakage Past a Defective Wheel Bearing.*—Oil seal will also affect the brake linings and the efficiency of braking. Build up of pressure in the axle casing owing to a defective oil breather will cause this difficulty, as also will too high an oil level or the employment of an unsuitable grade of lubricant.

Loose Rear Hubs

When a rear hub is found to be loose on its respective shaft splines the nut on the axle shaft should immediately be tightened to the appropriate tightening torque — 125lbs. ft. is specified. If this precaution is neglected damage will soon be caused to the axle shaft and rear hub splines.

Providing the nut is maintained at its correct tightness and the splines in the rear hub are correctly positioned in the special split collar and on the half-shaft, this trouble should not be experienced.

Brakes

Lockheed brakes are fitted, the front brakes being of the two leading shoe type and those at the rear have one leading and one trailing shoe.

Handbrake Adjustment

Adjustment of the brake shoes, as described in the Instruction Book, automatically readjusts the handbrake mechanism. The brake rods on the back axle are correctly set at the factory and, under normal conditions, they should not require any adjustment, which also applies to the handbrake cables. Where for any reason it is necessary to replace the brake rods or cables, or if it is necessary to remove these, the following procedure should be adopted.

The approximate centres for the brake rods should be ensured and should be 28.69in. and 14.88in. respectively for long and short links.

The handbrake lever should be adjusted by nuts on the yoke piece attached to the end of the longer of the two cables at the handbrake lever end. The normal cable adjustment should allow the handbrake lever to be fully "o" at three or four notches.

Brake Pedal Adjustment (Fig. 18)

The correct amount of free play between the rod (G) and piston (L) is set when the vehicle is assembled at the factory and should not be altered. If the adjustment has been disturbed for any reason, reset the length of the rod connecting the push rod to the pedal, so that the pedal can be depressed approximately $\frac{1}{2}$ in. before the piston (L) commences to move; this free movement can be readily determined if the pedal pad is depressed by hand.

It should be noted that an incorrectly positioned floor mat or other obstruction may foul the pedal and prevent the complete return of the pistons to the "off" position when the adjustment is actually correct.

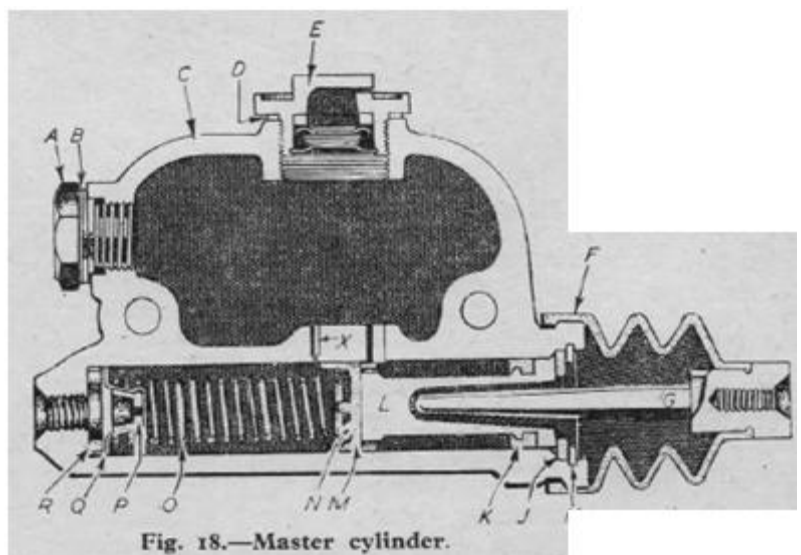

(To be continued)

Overhauling the Triumph Mayflower

Practical Motorist & Motor Cyclist August 1958

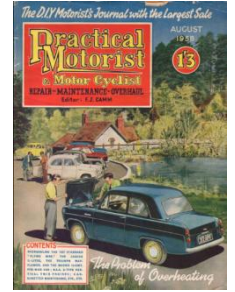

Removing and Reassembling the Master Cylinder and Adjusting the Carburetter

Removing the Master Cylinder

DISCONNECT the pressure pipe from the cylinder, remove the fixing bolts and detach the rubber boot (F) , Fig. 18, from the cylinder (C), leaving the boot and push rod attached to the brake pedal. Unscrew the filler cap (E) and drain fluid into a clean container.

To dismantle the master cylinder, push the piston (L) down bore of cylinder to release pressure on piston stop (J), then remove circlip (H) and piston stop. Withdraw piston, rubber cup (M), return spring (O), valve body (Q), complete with rubber cup (P) and rubber washer (R). Using fingers only, to prevent damage, remove the secondary cup (K) by stretching it over the piston flange.

Reassembly of Master Cylinder

Thoroughly clean all rubber parts in Lockheed brake fluid only. All traces of petrol, paraffin or trichlorethylene, used on metal parts must be removed before reassembly. Examine all rubber parts for damage, before reassembly. It is generally good practice to replace all rubbers as a matter of routine, when rebuilding a master cylinder.

Note the following:

1. Ensure that the by-pass port (X, Fig. 18), is clear by probing with a piece of 23 s.w.g. wire or smaller. Access to this port may be obtained through filler cap orifice.
2. Immerse all parts in brake fluid and assemble.
3. Fit the secondary cup (K) on piston so that the lip of the cup faces the piston head. Work the cup round the groove gently with the fingers thus ensuring it seats properly.
4. Locate the rubber washer (R) in the bottom of the cylinder bore. Fit the rubber cup (P) in the metal body (Q) and assemble the body on the larger end of the return spring. Assemble the retainer (N) on the smaller end of return spring and insert the assembly in the cylinder so that the valve body is in contact with rubber washer.
5. Insert the main cup (M) in the cylinder, lip foremost, without damaging or turning back the lip.
6. Push the piston (L) into the, cylinder, avoiding damaging or turning back the lip of the secondary cup (K) . Insert piston stop (J), circlip (H), ensuring that it beds evenly in its groove.
7. Fill the reservoir with clean Lockheed brake fluid and test the master cylinder by pushing the piston inwards, allowing it to return unaided; after a few such applications fluid should flow from the outlet connection.

Refitting the Master Cylinder

1. Insert the push rod (G, Fig. 18) in the piston (L) and assemble the boot (F) on the cylinder (C) so that the breather hole in the boot is at the bottom with the master cylinder in its fitted position.
2. Fit the master cylinder to the mounting bracket, picking up the adjustable push rod attached to brake pedal.
3. Check the pedal adjustment, as described above, and "bleed" the system.
4. Ensure that there is no leakage in the hydraulic system by applying the pedal hard whilst an assistant inspects the various unions in the pipe line.

Front Wheel Cylinders

The front wheel cylinders are firmly secured to the back plates inside the brake drums and between the shoe extremities. One cylinder is mounted at the top and the second at the bottom of each back plate and each cylinder operates one shoe only

To Remove the Front Wheel Cylinder

1. Jack up the vehicle, remove the wheel and back off all available adjustment and withdraw brake drum after removal of two grub screws.
2. Pull one of the brake shoes against the load of the pull-off springs away from its abutment on the closed end of the adjacent cylinder and slide "Micram" mask off the piston cover of the operating cylinder. On releasing the tension of the pull-off springs, the opposite brake shoe will fall away.
3. Remove the flexible hose adopting the procedure given in the "Front Suspension" instructions.
4. Remove the banjo bolts on both cylinders and withdraw the banjo adaptors complete with the bridge pipe.
5. Remove the nuts and withdraw wheel cylinders from back plate.

Refitting Front Wheel Cylinder

Position the wheel cylinder on the back plate and secure in position with nuts and spring washers. Fit the bridge pipe and banjo connections on the wheel cylinders, providing the banjo bolts with new copper gaskets to ensure pressure-tight joints. Refit the flexible hose into the banjo connections, using a new copper gasket and tightening securely. Mount the opposite end of the hose in the wing valance. Reassemble brake shoes, locating the "Micram" adjusters in the slots in the leading tip of each shoe, with the masks in position. Fit the brake drums, "bleed" the system and adjust the brake shoes. Check hydraulic system for leakage from the various unions whilst applying the footbrake hard.

Rear Wheel Cylinder

The rear wheel cylinder is fitted in an elongated slot in the rear back plate, and is free to slide in the slot between the tips of the brake shoes which are of the leading and trailing, shoe type.

Removal

Jack up the vehicle, remove the wheel back off all available adjustment, disconnect the rod from the handbrake lever and then remove the brake drum after withdrawal of two screws. Remove the brake shoes as explained for those fitted to the front wheels.

Unscrew the banjo bolt securing the banjo adaptor to the wheel cylinder, disconnect the rod from the handbrake lever and remove the rubber boot. Swing the handbrake lever until the shoulder is clear of the back plate and slide the cylinder casting forward. Pivot the cylinder about its forward end and withdraw the rear end from the slot in the back plate, a rearward movement of the cylinder will now release the forward end from the back plate.

Testing the Petrol Pump (A.C. "Y")

With the engine switched off, disconnect the pipe to the carburettor at that unit's end, leaving a free outlet from the pump. Turn the engine by hand when there should be a well-defined spurt of petrol at every working stroke of the pump, i.e., once every two revolutions of the starting handle.

If this test proves negative, before condemning the fuel pump ensure that the petrol pipe from the pump to the tank is not sucking air, or that it is restricted by the disintegration of the inside of the flexible coupling.

If the petrol pump, the detachable components of which are shown in Fig. 19, is established as being responsible for the trouble it should be ensured that the cover gasket is in good order and that

there is no question of an air lock. It is necessary also to clean the filter gauze and reservoir uncovered by the latter's removal.

Details for further dismantling of the petrol pump are outside the scope of this article and you are recommended to refer the repair of the unit to Messrs. A. C. Delco Ltd., of Dunstable, or to one of their local agents.

Petrol Pump Pressure

This has an important bearing on petrol consumption. The specified pump pressure is 1 ½ to 2 ½lb. and if this is substantially exceeded it will overcome the resistance offered by the needle valve in the float chamber of the carburetter. Where pump pressure is excessive, its effects will obviously be more noticeable at fairly high speeds and the smell of petrol when driving the car, associated with heavy petrol consumption, is a sign. To reduce pump pressure extra packings can be fitted between the petrol pump and cylinder block thereby reducing the stroke of the plunger.

The Carburetter

A Solex Carburetter, Type 30 FA. 10 is fitted to the engine and the jet setting used is: 21 choke tube (K), 105 main jet (G), 220 air correction (A), 2.0 air bleed for pilot (U), 45 pilot jet (g), 2.0 needle valve (not shown), 120 starter jet (Gs), 4.5 starter air jet (GA). (With later models 8mm).

Adjustment of Carburetter

The jet setting employed with the carburetter is that decided for all round performance and economy after numerous experiments at the factory in collaboration with Messrs. Solex. It should not be altered without sanction of the manufacturers Messrs Solex, who are always willing to advise.

Slow Running Adjustment

The idling or pilot jet (g) provides the necessary output for idling. The slow-running screw mounted the abutment plate of the throttle lever limits the closing of the throttle and fixes the idling speed.

The mixture adjustment (W) permits the amount of mixture supplied to the engine to be varied. By turning it anti-clockwise it is increased and vice versa.

Poverty of mixture may be recognised by the irregular behaviour of the engine and a tendency to stall. Over-richness will cause the engine to "hunt" and tend to stall when the hunt becomes excessive, it will also be associated with black smoke from the exhaust which smells of petrol.

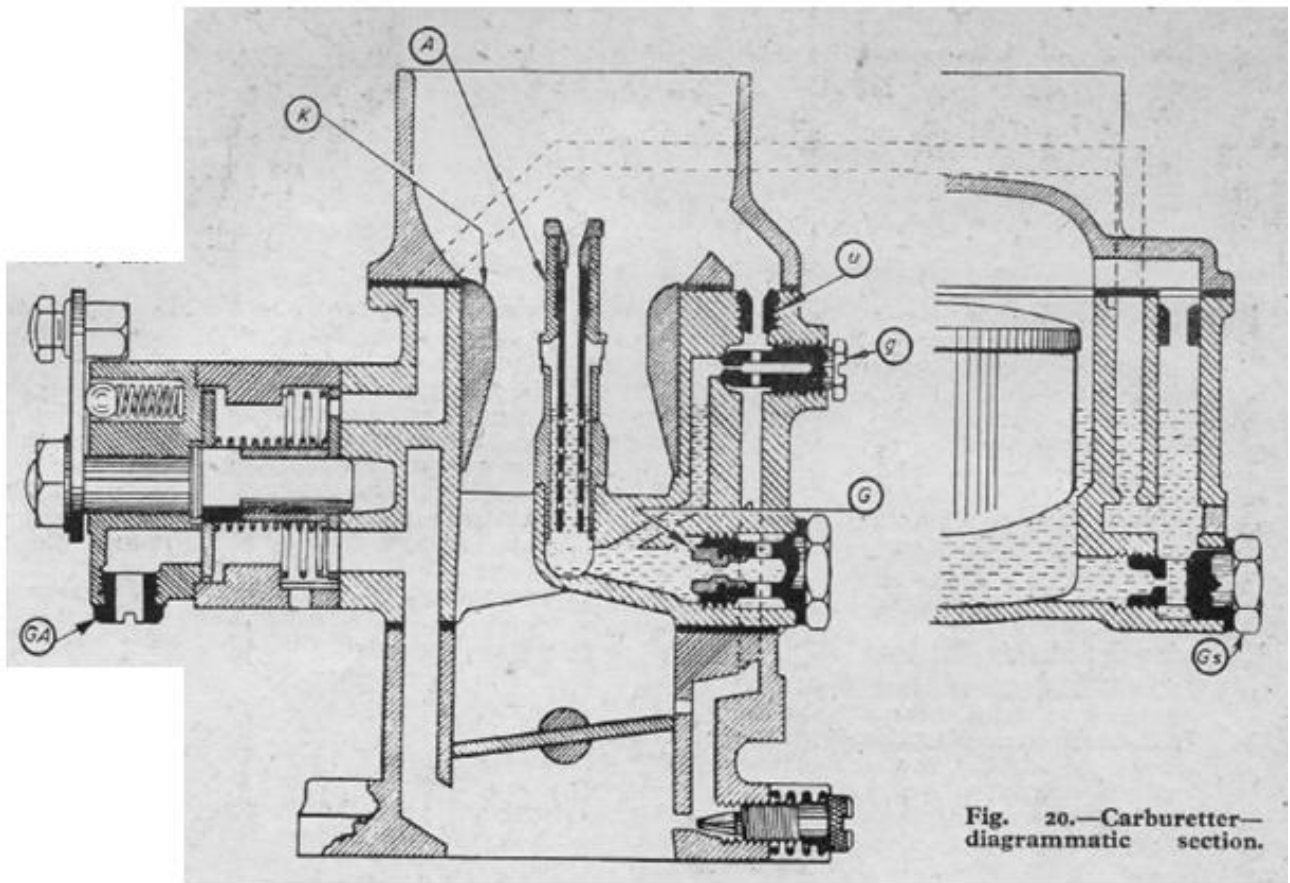
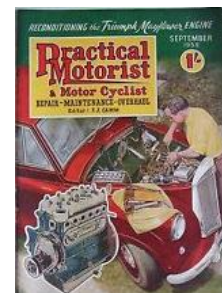

Fig. 20.—Carburetter—
diagrammatic section.

Reconditioning the Mayflower Engine

Practical Motorist & Motor Cyclist September 1955



Constructional Features: Lubrication and Ventilation Systems: Decarbonising: Engine Removal: Oil and Water Pumps

DISTINCTIVE for its knife-edge styling, the Triumph Mayflower is of 1½ litre capacity and thus in a class which many motorists consider has much to recommend it. This is a class in which overall dimensions of the vehicle impose few problems of parking and garage accommodation, in which power and speed are superior to those in the small car or baby class, yet in which fuel and oil consumption remain relatively modest.

It will be recalled that 1½ litre equals 1,250 c.c. The Mayflower engine, a side-valve, is of 1,247 c.c., 63 mm. bore by 100 mm. stroke, four-cylinder, firing order 1, 3, 4, 2, compression ratio 6.8 to 1, developing 38 b.h.p. at 4,200 r.p.m. and providing 65 m.p.h. in top, 40 m.p.h. in second, 18 m.p.h. in first, with petrol consumption 35 m.p.g. and oil consumption 2,000 m.p.g.

Lubrication System

The crankshaft, carried in three main bearings, drives the camshaft through sprockets and chain. A skew gear on the camshaft drives a vertical shaft at the top of which is the distributor, while at the bottom is located the oil pump. A cam integral with the skew gear on the vertical shaft operates the petrol pump by means of a push rod which passes horizontally through the engine.

The double-rotor type oil pump is driven from a tongue on the lower end of the vertical shaft. Oil enters the pump from a floating intake, and is forced up round the vertical shaft, past the relief valve on the side of the engine, where it is accessible from the outside for adjustment or renewal. This valve originally consisted of a spring-loaded ball, though later a plunger was introduced. Just beneath the bush of the vertical shaft the oil enters a longitudinal gallery, and thence goes directly to the three main bearings; two intermediate camshaft bearings are supplied through restrictors pressed into the casting, while front and rear camshaft bearings are supplied through restricted channels from the passages carrying oil to the front and rear main bearings. Bypasses from the intermediate camshaft journals feed the tappet blocks.

Big-end bearings are supplied from the main bearings through drillings in the crankshaft, and the surplus forced from the big-ends lubricates cylinders, pistons, gudgeon pins, etc. Timing chain and sprockets are fed from the front camshaft journal in a similar manner.

Fig.1 shows a cross-section of the engine with

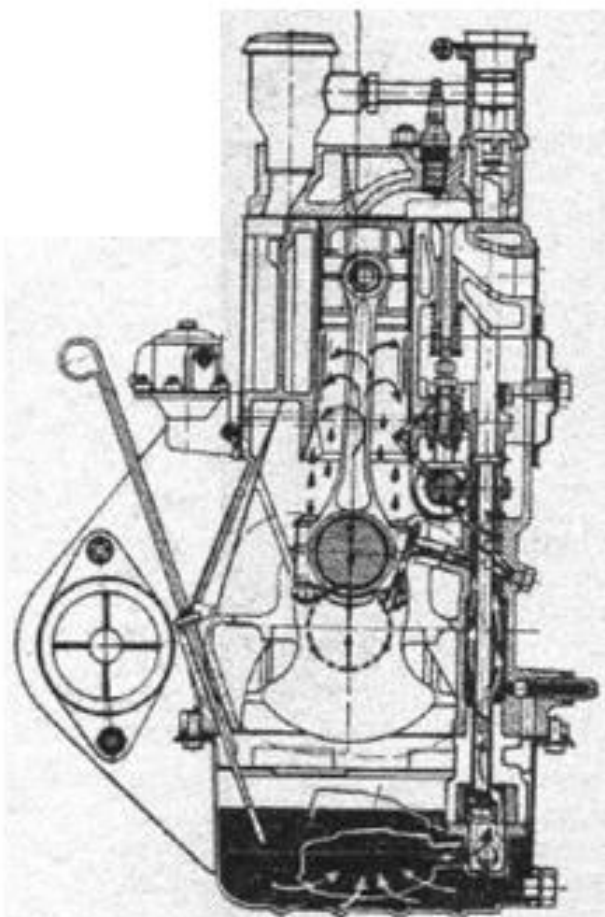

Fig. 1.—Cross-section of Mayflower engine showing lubrication system.

the flow of oil.

Sump capacity is 6 pints, and the pressure should be between 40lb. and 60lb. at normal speed with the engine hot.

Ventilation System

Crankcase ventilation is accomplished on the sealed engine principle, in which a depression is created in the crankcase through a pipe connected to the induction manifold. The important features of this system are engine joints must be sound to remain sealed; the metering valve (Fig. 2) in the manifold must be kept clear of carbon for the system to function. The valve contains a stainless steel pin, and movement and vibration should maintain it free. Nevertheless, it should be examined from time to time during servicing operations, but not altered in any way. If the valve becomes choked with carbon pressure will be created in the crankcase and oil may be forced through joints or through the front seal behind the crankshaft pulley or past the rear seal in front of the flywheel—in which case oil would pass into the clutch casing, and clutch troubles might ensue.

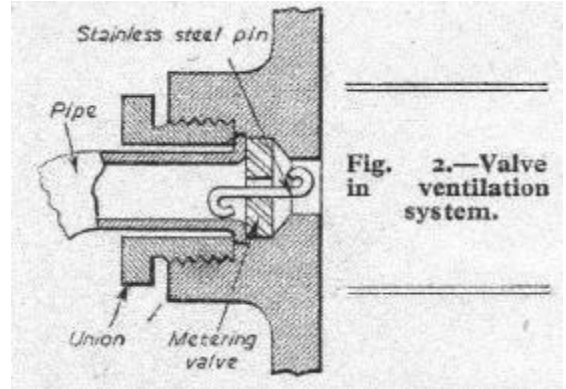

Fig. 2.—Valve in ventilation system.

Air is taken from the carburettor silencer through a pipe to the neck of the oil filler, where it enters the crankcase. Having passed round and ventilated the crankcase, it is drawn out—along with fumes—from a pipe connected between the tappet cover and the manifold. All joints in the pipe-lines, filler cap, etc., must be maintained airtight.

Cooling System

Cooling, which is thermostatically controlled, is effected by a pump and integral fan, the belt drive from the front of the crankshaft being triangulated round the dynamo pulley, with adjustment for tension through tilting the dynamo. The capacity of the cooling system is 12 pints, or 13 pints when a heater is fitted.

The thermostat is situated in an aluminium alloy housing on the cylinder head, and can be removed by lowering the level of the coolant in the radiator and detaching the main outlet hose. The thermostat should begin to open at about 158 deg. F. And be fully open at 176 deg. F. In very cold climates a thermostat operating 185 deg. – 195 deg. F. is recommended. Testing of the thermostat is effected in a bowl of water, which can be heated, or to which hot water can be added; verification is made to an accurate thermometer.

Ignition System

The distributor mounted on the cylinder head is driven from an offset slot at the top of the vertical shaft. The distributor can be detached complete for cleaning or when decarbonising, and the timing will not be disturbed so long as the clamp is not loosened. Fig. 3 depicts details of the distributor.

With the rotor pulled off a few drops of oil can be applied to the centre for lubrication of the cam bearing, and a trace of grease can be put on the cam, a drop of oil on the rocker pivot. Contact breaker gap should be 0.010in. to 0.012in., and the timing 2 deg. before T.D.C. fully retarded. Champion type NA.8 sparking plugs, $\frac{3}{8}$ in. reach, are recommended, set to .025in. gap.

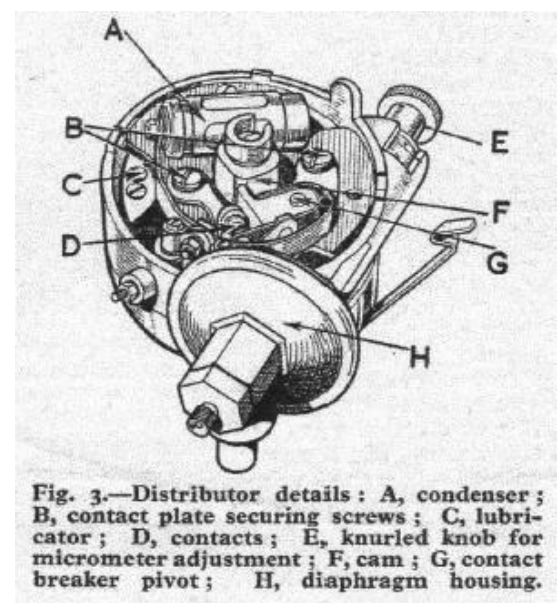

Fig. 3.—Distributor details: A, condenser; B, contact plate securing screws; C, lubricator; D, contacts; E, knurled knob for micrometer adjustment; F, cam; G, contact breaker pivot; H, diaphragm housing.

Top Dismantling

Decarbonising should be performed when there is a falling off in power accompanied by loss of compression, indicating leaking valves; pinking may also be noticed on occasion when the engine is out

of tune. Top dismantling procedure is as follows. The cooling system is drained and the top water hose and bypass hose disconnected. The air cleaner is detached, removing hose and nuts. The distributor is removed complete from the cylinder, not touching the clamp, (It is advisable, also, to disconnect a battery lead to obviate shorts.)

From the carburetter are detached throttle and choke connections and pipe to pump. Down pipe and crankcase ventilation pipe are detached from manifold, and this and carburetter removed. The tappet cover is removed and heater, if fitted, disconnected; also capillary tube for thermometer gauge, unscrewing union nut. The ventilation pipe is removed from the oil filler, and the cylinder head lifted, following withdrawal of throttle bracket and coil brackets.

The vertical (distributor and pump) driving shaft abutment brackets (Fig. 8) are removed, with care that the shims are not dropped; this shaft must not be lifted or the gear will be disengaged, and it will be drawn from the oil pump at the bottom. Outer securing bolts are removed from the tappet guide blocks, and these withdrawn. The space over the camshaft should be covered before valve collars and springs are removed. Valve spring securing collars have a large and a small hole intersecting, so that after lifting they can be moved sideways and slipped off the valves.

Valves and Springs

Decarbonising is performed in the normal manner, filling the two bores where the pistons are at B.D.C. with clean rag. A ring of carbon 1/8 in. wide should be left round each piston. Care should be exercised to get all faces clean without scratching and without damaging valve seatings. Valves are numbered and should be retained in the correct order for refitting. Seat angles are 90 deg., while seating angles in the block should be 89 deg. Where valves are pocketed or seatings lower than normal after re-cutting a chamfering cutter of 150 deg. angle is employed.

Valve stem diameters are .2475in.-.2465in. ; valve guide diameters .2495in.-.2505in. Clearance when new is .0021in. - .004in. The distance of the valve guides from the cylinder head face is .97in. The outside diameter of guides is .4385in.--.4395in. Valve springs are as follows: Number of free coils, 7 ; fitted length, 1 9/32in.; load at fitted length, 22lb. (plus 2lb. minus 1lb.); valve lift, 1/4 in. plus 0.010in. ; load at full lift, 37lb.

Reassembly

Cylinder walls can be lightly oiled before fitting the head, and surplus wiped off at T.D.C. Valve stems should be oiled during assembly, and the spring collars should be placed with the large hole inwards. To set the tappets the piston of No. 1 cylinder is brought to T.D.C. of compression stroke, where both valves are closed. Having set the tappets of this cylinder, the handle is rotated half a turn, then the tappets of No. 3 cylinder set, and when this has been done the handle is rotated a similar amount to bring the piston of No. 4 cylinder to T.D.C. compression stroke, the tappets of this being set, and the procedure continuing for No. 2 cylinder.

Tappet clearance is .015in. as checked by a feeler gauge. A type of wedge made of fiat plate can be used between a pair of tappet stems to prevent rotation while the locknuts are loosened and the adjustment made; this plate should be removed, however, when making the final check of clearance. Fig. 4 depicts the tightening sequence for the cylinder head nuts, which should be gone over several times to pull the head down gradually and evenly.

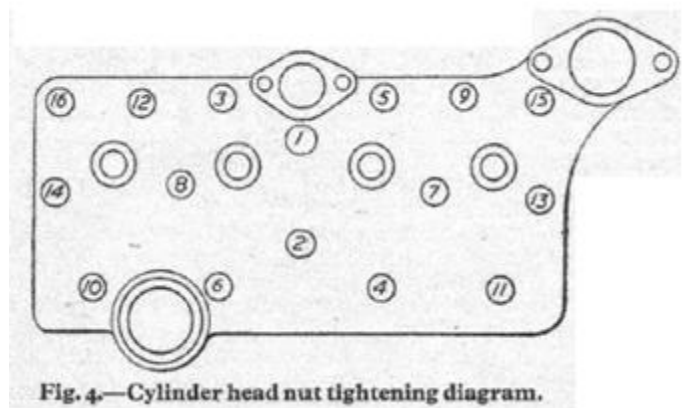

Fig. 4.—Cylinder head nut tightening diagram.

Engine Removal

The Mayflower engine and gearbox can be removed together as a unit, or the gearbox can be removed separately—which would be done in the case of trouble with this unit or with the clutch alone. A small crane or block tackle is necessary for lifting the engine-gearbox unit, through a lifting bracket attached to the cylinder head, the rear of the car being jacked up and supports placed beneath the rear jacking brackets.

The following is an outline of the removal procedure. Bonnet is removed, radiator detached from grille, drained and disconnected top and bottom, battery disconnected. Removing three bolts each side (caged nuts), the radiator block can be withdrawn. Self-tapping screws are removed securing grille to valances, and bolts to cross member, then grille removed. After removal of bolts, cross member bracket is lowered and removed from front. The following are detached: Connections to dynamo and starter; hose to petrol pump; exhaust down pipe; thermometer lead from cylinder head; heater connections; oil pressure gauge flexible hose; throttle wire.

The car is then jacked up at the rear as previously mentioned, and propeller shaft removed. Clutch coupling rods and gear-operating cross shafts are disconnected, and speedometer drive. With lifting bracket attached to the cylinder head, the weight of the unit is taken, and two nuts are removed which secure the gearbox extension bracket to cross member. The weight of this member is taken on a jack, petrol pipe clip removed and two bolts and member withdrawn. Removing the bolts which hold the front flexible mountings of the engine to chassis side members the unit can be lifted out—with care for the centre tie rod of the steering.

Engine Dismantling

Dismantling is a fairly straightforward process and need hardly be discussed in detail. The gearbox is, of course, removed early in the procedure, followed by the clutch to lighten the unit. Other components follow in convenient order.

Attention should be given to shims under the starter dog nut, which set the starting handle in the correct position for compression; shims between the abutment brackets for the vertical shaft (already mentioned in decarbonising) should not be overlooked, as they should just provide clearance for the shaft; also shims are situated behind crankshaft sprocket to set chain line.

A puller is required for the crankshaft pulley, and the timing case can be withdrawn with its packing seals; an oil thrower is fitted between the bosses of the pulley and crankshaft sprocket. The timing sprockets should be marked with two lines which come together, and there should be a punch mark at the hole which is next to the cutaway on the camshaft. These enable the camshaft sprocket to be correctly refitted, and the camshaft retuned—with the driving side of the chain tight. The abutment brackets for the vertical shaft and the tappet guide blocks and valves can be removed as for decarbonising. A pin with a clip is fitted through the boss of the skew gear of the vertical shaft (Fig. 8) and these should be removed, followed by the shaft and gear.

Sump and flywheel are removed, as are oil pump and floating filter. The aluminium oil retaining cover at the rear of the crankshaft is removed; then the sealing blocks, taking out the screws with a large screwdriver.

Connecting Rods

Connecting rods are offset (Fig. 5), and these and the markings should be noted for reassembly. The big-end caps must not be filed to adjust for wear since this would render the assembly non-standard. In any major overhaul it is recommended to check or have checked by a competent firm the alignment of the big-ends and small-ends. New clearances on big-end bearings are between .001in. and .002in., while side clearances lie between .008in. and .010in.

The standard crankpin diameter is 1.750in. +.0000in. -.0005in. The permissible worn diameter, as checked by micrometer, is 1.748in. At anything less than this the crankshaft must be reground and

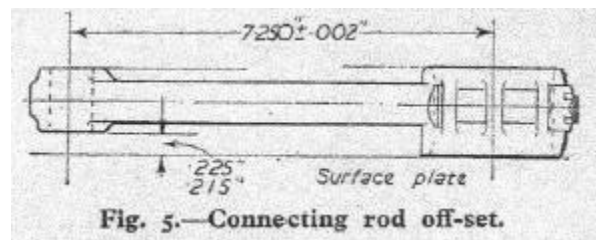

standard undersize bearings fitted. Clearance when new on the gudgeon pin is .0002in. at 68. deg. F., that is a thumb press fit. The permissible worn clearance is .002in. The gudgeon pin diameter is .75010in. - .74985in.

Pistons

In manufacture selective assembly is employed, and the code markings F, G or H are stamped on the crowns of the pistons. If cylinder bores are worn in excess of .0071in. at the top and .005in. at the bottom reboring is recommended to ensure a satisfactory result, new pistons and rings then being fitted.

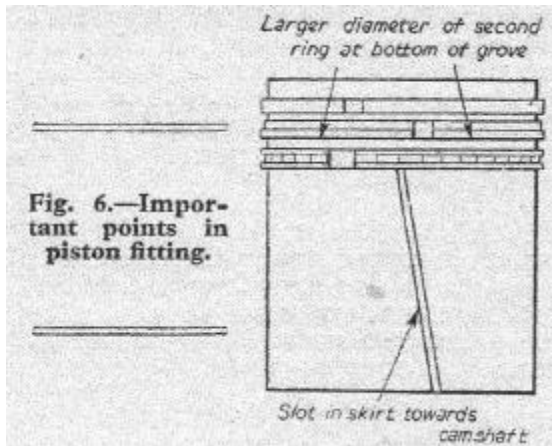

Code dimensions are as follow: F cylinders 2.4799in.-2.4802in.; G cylinders 2.4803in.-2.4806in.; H cylinders 2.4807in.-2.4810in.; F pistons, top diameter 2.4774in.-2.4777in., bottom diameter 2.47865in.-2.47895in. ; G pistons, top diameter 2.4777in.-2.4781in., bottom diameter 2.47895in.-2.47935in. ; H pistons, top diameter 2.4781in.-2.4785in., bottom diameter 2.47935in.-2.47975in. New clearances are at tops of pistons .002in. to .003in., and at bottoms of pistons .001in. to .0015in.

The skirt of the piston is slotted and piston and connecting rod should be assembled so that with offset and numbers correct on the connecting rod the slotted side of the skirt towards the camshaft or on the side of minimum thrust. A stepped second ring is employed and this should be fitted with the larger diameter downwards (Fig. 6). This ring, however, should be marked T on its top face. Ring gap clearances should be between .004in. and .008in., side clearances .001in. to .003in. Permissible worn side clearance is .005in. The top ring is chromium plated.

Main Bearings

New clearances on the main bearings are .001in. to .002in., with end float .004in. to .006in. The permissible worn diametral clearance is .006in., which when exceeded calls for regrinding the crankshaft and the fitting of new undersize bearings. End thrust can be checked with a dial indicator mounted to bear on a crankweb (Fig. 7); it can also be verified somewhat less accurately with feeler gauges. Halved thrust washers with steel backs are used to regulate endplay, and these may be obtained plus .005in. for taking up wear. Should insufficient endplay obtain the thrust washers are rubbed down on the steel backs on a sheet of emery cloth on a surface plate. The crankshaft diameter, new, is 2.0000in.—1.9995in.

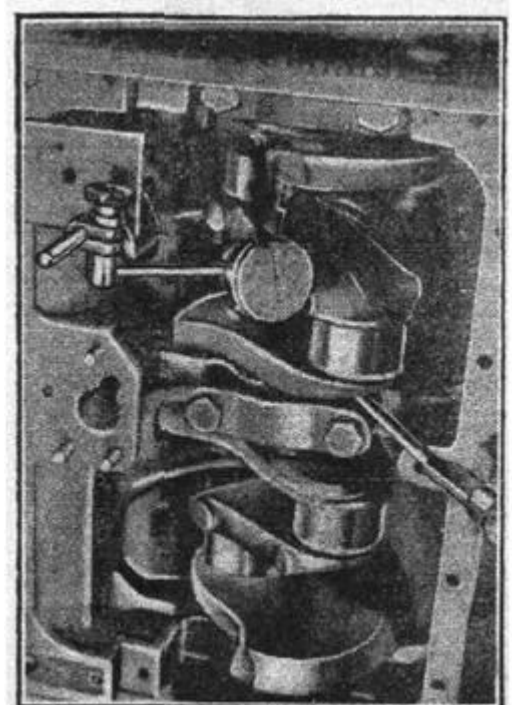

Camshaft Bearings

If necessary the camshaft can be withdrawn with the engine *in situ*, removing radiator block and grille, manifold, tappet cover, etc. It is essential always to remove the petrol pump before the vertical shaft (Fig. 8) is lifted for the operating push rod to be clear of the cam. The crankshaft pulley and timing case must, of course, be removed, the camshaft sprocket and chain, and the keep plate for the camshaft, which can be drawn out.

It is considered unlikely that wear of the camshaft journals in the cylinder block will ever attain dimensions to demand replacements being made—other than should the engine be damaged by neglect of the lubrication system in some respect.

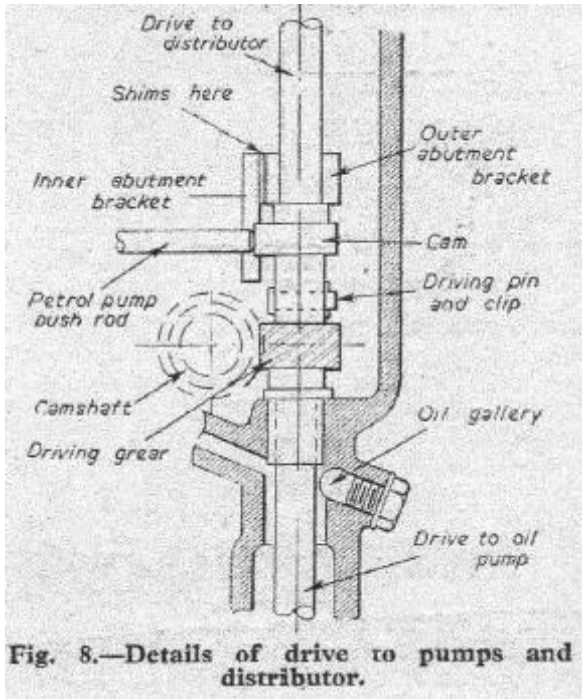

Camshaft dimensions, new, are as follow: Front journal 1.6845in.-1.684in. ; intermediate and rear journal 1.497in - 1.4965in. Clearance, new, is .003in.--.004in., and permissible worn clearance .010in. Endplay new is .003in.—.0065in., and may be up to .012in. when worn.

Should the camshaft be changed at any time the type should be checked and the driving gear of the vertical shaft (Fig. 8) renewed if necessary. This will be for engines up to and including No. TT.1407E, which were fitted with special alloy cast-iron camshaft, chilled on cam faces and journals. Beginning at No. TT.1408E, engines are fitted with casehardened camshafts, bonderised and graphited to promote good bearing surfaces.

Oil and Water Pump

Fig. 9 illustrates the oil pump—a double-rotor type

which is designed to provide a considerable surplus above the requirements of the engine, which, coupled with the minute wear ordinarily occurring in service with this type of pump, should ensure virtually no trouble in the normal life of the car. New endplay between the rotor assembly and the cover is .0005in.—.0025in. In the event of increased clearance from wear, as checked by a straight-edge across the base of the body, using feeler gauges, rectification can be made by careful lapping. The shaft for the inner rotor is slotted at the top to engage with the tongue of the vertical shaft. The rotor is pressed on its shaft and pegged.

The oil pump may be removed by removing the sump and the three nuts from the studs securing the pump to the crankcase.

The water pump can be removed after the radiator block has been removed. Driving belt should be detached, two nuts removed and the bolt loosened and screwed out as the pump is withdrawn; this will leave the water housing in place.

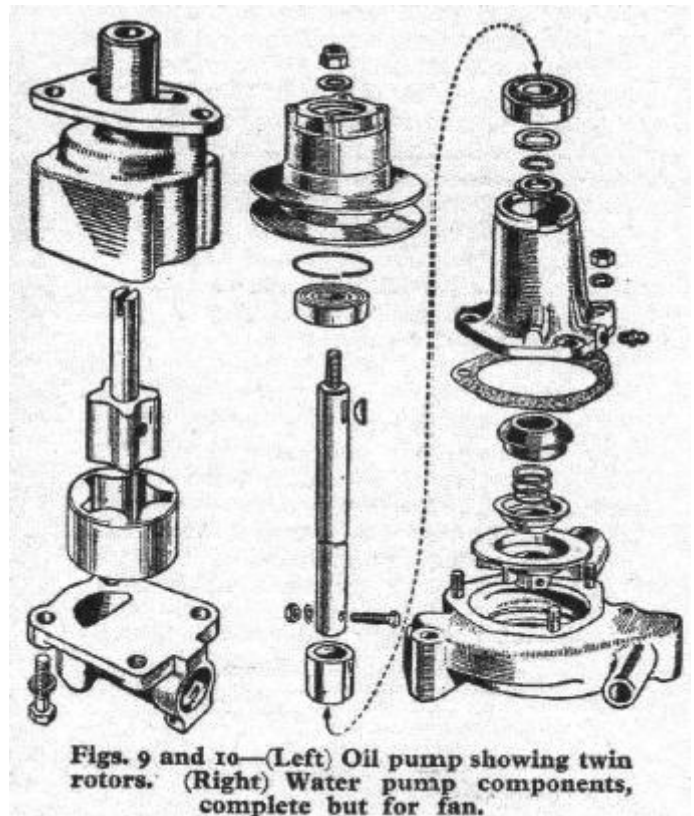

To dismantle the water pump (Fig. 10) the following is the procedure. The fan blades are removed, the nut and washer from the pump spindle, and the pulley withdrawn with a puller. The screw securing the rotor is removed and the rotor carefully levered off. The locating circlip for the bearing is removed and the spindle tapped out from the rear of the housing, complete with bearings, etc.

Timing

Little difficulty should be experienced in retiming the engine. Nos. 1 and 4 pistons should be at T.D.C. and the marks of the timing sprockets in line, the punch mark on the camshaft sprocket near to the cutaway on the camshaft, the driving side of the chain tight. Timing is as follows: Inlet opens 10 deg. before T.D.C., closes 50 deg. after B.D.C.; exhaust opens 50 deg. before B.D.C., closes 10 deg. after

T.D.C. Tappet clearances should be .020in. for timing verification; normal running clearance is .015in., both inlet and exhaust.

For ignition timing the engine should be No.1 piston T.D.C., compression stroke, when the slot of the vertical shaft should be at an angle of approximately 45 deg. across the top of the cylinder block. The distributor can be held in its fitted attitude on the shaft with the rotor pointing to No. 1 electrode, the points just opening. In the event of an error the vertical shaft can be raised and the skew gear appropriately re-meshed.

Clutch

The clutch is a Borg and Beck type with a single centre plate and a graphite release bearing or thrust block. There should be clearance of $\frac{1}{16}$ in. at this point to ensure proper operation and approximately 1in. free movement on the clutch pedal. The release levers should move $\frac{1}{2}$ in. towards the flywheel in releasing the clutch and the stop should be adjusted to limit this movement. A centring mandrel is illustrated in Fig. 11 for use when assembling the driven plate.

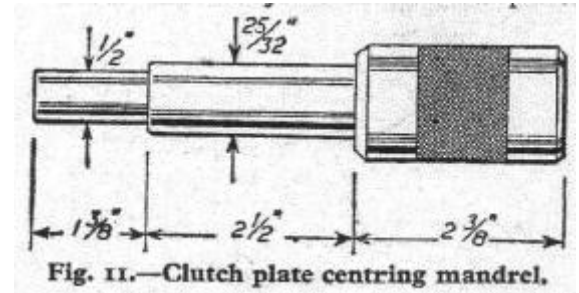

Fig. 11.—Clutch plate centring mandrel.

Maintaining a Mayflower

Car Mechanics, February 1960

Keep your ten-horse Triumph in top condition with Norman Davis' hints



IN the three years between 1950 and 1953, the Triumph Mayflower made more friends than perhaps any other small luxury saloon in the same period of time.

One of its most endearing characteristics is its trouble-free performance. But, much after 40,000 miles, the car will need a certain amount of attention. I recently checked mine up thoroughly and the points raised in this article should bring any Mayflower back to "as-new" condition.

Top overhaul is, in common with most side-valve engines, fairly straightforward although slightly complicated by the high wing valves which necessitate all but the tallest person standing on a box to reach the unit.

Dismantling entails draining the cooling system, disconnecting the battery and then removing the air cleaner which is best achieved with the brackets still attached to the cleaner. The carburettor controls are disconnected, the petrol pipe uncoupled from the carburettor, the exhaust pipe detached from the manifold and the ventilation pipe fitted between the manifold and the tappet cover plate removed.

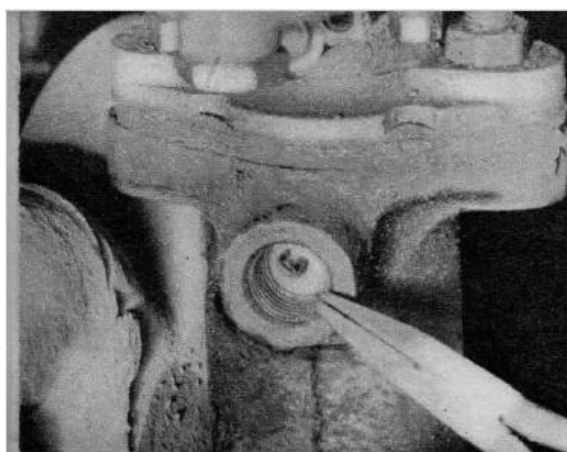

Removing the crankcase ventilation restrictor valve from the inlet manifold with pointed-nose pliers. Make sure there is no carbon on this valve or its seating

It is then possible to remove the two bolts and the two nuts holding the manifold to the engine after which the manifold can be lifted away complete with the carburettor and the manifold drain pipe. The only precaution necessary is not to tip the manifold downwards at the front as it is possible for the little restrictor valve to drop out and be lost. The valve is fitted in the drilling for the ventilation pipe and without it the engine will not idle.

It is worth checking that carbon has not formed between the stainless steel trembler pin and the washer which forms the valve as this is prone to blockage which can cause excessive crankcase pressure; this in turn will account for oil leakage, especially from the rear main bearing.

A sure symptom of no ventilation will be the formation of rust inside the oil filler cap and in the inlet ventilation pipe fitted between the filler and the air cleaner. If it is ever necessary to

clear the hole in the valve always use a No. 60 drill (0.040in. dia.) as this controlled air leakage is compensated for in the carburettor settings.

The cylinder head is removed after displacing the top water hose, the petrol pipe clip fitted on the forward thermostat stud and the cylinder head nuts. Some difficulty is frequently encountered in removing the expansion bulb of the thermometer from the rear face of the head due to corrosion and in no circumstances should any effort be made to pull the capillary tube unduly as it is very fragile.

If the application of a penetrating oil does not free the corrosion, try removing the square-headed plug at the rear top face of the head (or the heater hose adapter, if fitted), when it is often possible to gently prise the end of the expansion bulb with a pencil until it is free.

If the bulb is absolutely immovable, remove the cylinder head with the capillary tube attached as there is sufficient slack in the tube to enable the head to be rested on the offside wing. Here the head can be decarbonised but be sure to protect the wing with an old coat if you value the paintwork. The distributor is best removed by taking the two nuts securing the pedestal bracket away after which the distributor can be lifted off as an assembly: The adapter fitted between the drive shaft and the distributor can easily be lifted out of position.

Removal of the tappet cover plate reveals the tappet blocks and the distributor/oil pump drive shaft. It is best to remove the tappet blocks but before this can be done it will be necessary to displace the drive shaft abutment bracket which is secured by two small bolts to the plate fitted between the two centre tappet block bolts. Care must be taken here to prevent any shims fitted behind the abutment bracket from falling into the engine. It should also be noted that the two centre tappet block bolts are longer than the outer ones.

The cotters used are peculiar to the manufacturers and consist of a circular plate with a central hole through which the valve stem passes. There is an adjoining larger hole which breaks into the central hole and the method

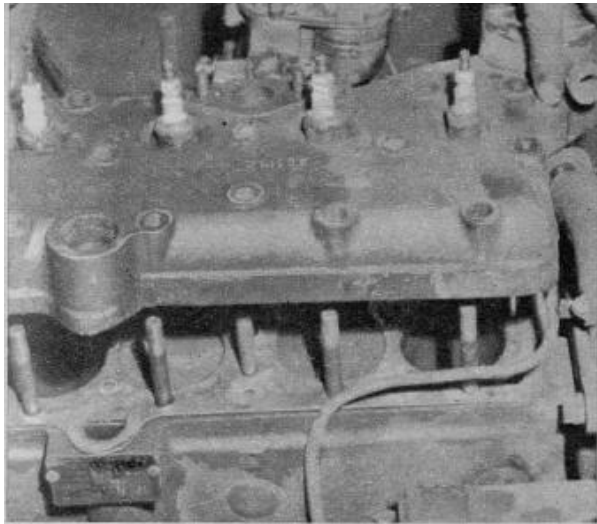

The light-alloy cylinder head should come off easily but if it sticks try soaking the studs with penetrating oil for 24 hours or using a specially designed cutting tool

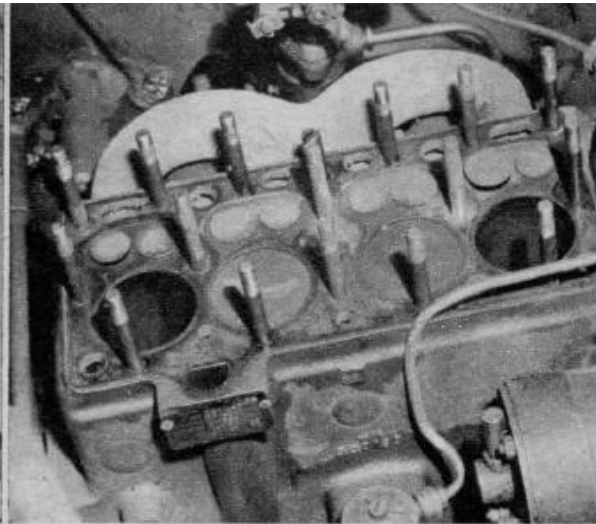

Here is the Mayflower engine with the head off. Don't scrape the piston crowns clean or oil consumption will rise. But the valves should be removed for a check

of removal is to compress the valve spring until the cotter is in line with a portion of the valve stem which is of reduced diameter. The cotter is then pushed sideways so that the valve stem slips into the eccentric hole after which the valve spring is decompressed.

The principles of decarbonising have been frequently discussed in CM before and any further description would only be repetitious but, if the faces of the tappet adjustment screws are badly indented, they should be replaced or alternatively the unworn perimeter can be removed with a grindstone or with emery cloth. Remember, worn tappet screws make tappet adjustment impossible. Be sure not to over tighten the tappet locking nuts as it is fatally easy to crack the cast iron tappets.

Before refitting the manifold, check that the drain pipe is not obstructed as this can cause difficult starting when the engine is hot. The drilling in the manifold often becomes choked with hard carbon and can be cleared with a No. 60 drill.

Fitting pistons, oil control rings or big end bearings is possible without disturbing the cylinder head, the dismantling procedure being as follows.

Drain the oil in the engine and remove the sump after which the floating uptake for the oil pump can be displaced by removing the, cotter pin. With the sparking plugs removed, the big-end cap on the connecting rod can be displaced after taking off the two split pinned nuts.

To remove the piston the big-end is raised slightly out of engagement with the crankshaft journal and then moved towards the offside of the engine. The crankshaft is then turned through 90— so that the journal points towards the nearside. It is then possible to lower the connecting rod until the piston is clear of the bore when it should be moved to the offside of the engine. If the crankshaft is then slowly rotated to bring the journal to t.d.c. it will be possible to lower the piston through the constantly varying space between the crankshaft and the cylinder block.

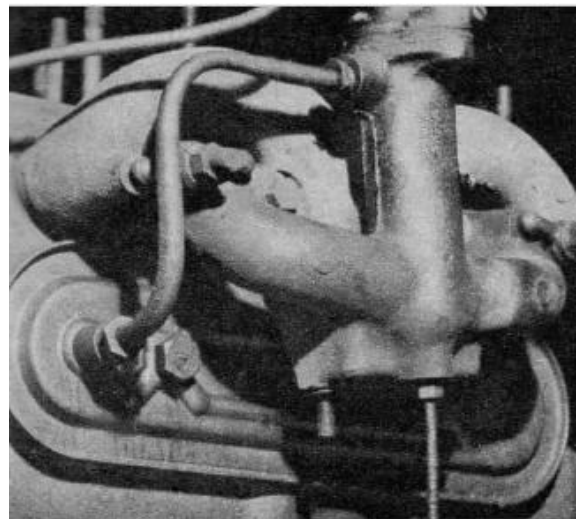

An often-overlooked item on the Mayflower engine is the manifold drain pipe coming from the base of the manifold. This must not be blocked or choked at all

Offset big-ends

Note that the big-ends are offset to the connecting rods. The correct position when refitting is for the wide offset on each pair of rods to face each other. Nos. 1 and 3 face rearwards while Nos. 2 and 4 face forwards. No. 1 cylinder is nearest to the radiator. Pistons must be fitted so that the split skirts face towards the nearside of the engine.

The oil pump floating uptake should be thoroughly washed in petrol prior to refitment as it is possible for the coarse mesh gauze to become choked and in severe cases this can cause a reduction in oil pressure. When

refitting the cotter pin to the oil pump, be sure to see that the uptake is not prevented from moving through its full range of movement due to the legs of the cotter pin fouling.

Such trouble can result in a loss of oil pressure except when the oil level is full and even then there can be a momentary loss of pressure when cornering.

The only adjustment required to the clutch is made by lengthening or shortening the bottom operating rod of the linkage so that there is 1in. lost motion on the clutch pedal. One can easily be misled by the pedal not being fully returned to its full rearward position on this model as there is a tendency for the return spring to be rendered ineffective because of the clamp which secures the front of the spring moving rearwards on the top operating rod of the linkage.

A simple way of overcoming this is to unhook the spring, slacken the clamp and retighten after repositioning with a small split pin or a small piece of tin interposed between the clamp and the rod.

This is really worth the effort as unnecessary wear occurs when there is no lost motion and even the weight of the pedal can accelerate wear on the carbon release bearing.

After many thousands of miles it is not unknown for the top operating rod to fracture and to obviate this the makers have modified the set up by using a double link and clevis pins instead of a rod. This is certainly worth fitting if trouble of this type is experienced or as a precautionary measure in the event of the clutch action having become unduly heavy in action.

When it is necessary to overhaul the clutch the gearbox must be removed from underneath the car as there are no detachable floorboards to facilitate its removal from inside. This is achieved in the following way, leaving the engine in position.

Gearbox removal

Disconnect the battery, drain the radiator, remove the top water hose and disconnect all attachments to the engine which will restrict its movement. The car must then be jacked up as high as possible and the body securely supported on stands—better still if a pit or ramp can be used. It is then necessary to remove the propeller shaft, disconnect the speedo cable, the clutch linkage and the gear change cross-shafts.

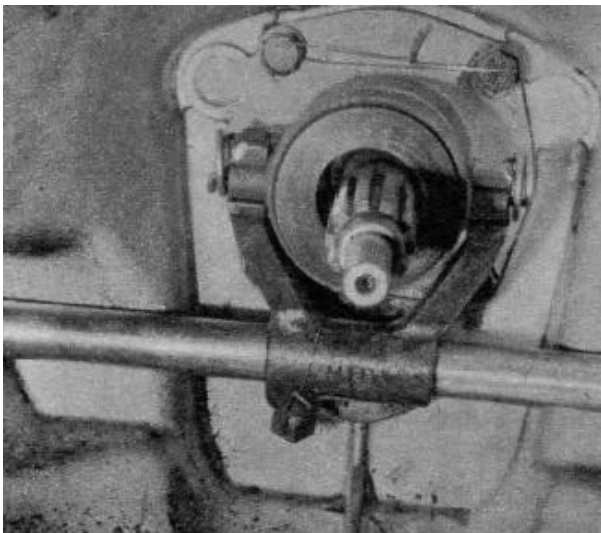

The effects of "riding" the clutch pedal can be seen in this picture of the carbon thrust which has moved sideways in relation to the pinion shaft in the centre

The supports for the exhaust system should also be freed to prevent any strain from being imposed. Using a block of wood to protect the sump from damage, use a jack to support the engine while the two bolts securing the gearbox bearer bracket to the body are removed—the right-hand bolt also secures the pivot bracket for the clutch linkage.

The jack is then lowered until the engine wedges itself in its compartment when the bell housing and starter bolts can be removed and the gearbox withdrawn.

The clutch is a conventional 7in. Borg and Beck unit and a replacement pressure plate assembly is available on an exchange basis. When replacing the pressure plate, centre plate and the carbon thrust, do not forget to renew the cross-shaft or bushes in the gearbox if worn. Sometimes the groove in the cross shaft or the locating bolt can be worn to such a degree that the carbon thrust is no longer centralised in relation to the constant pinion shaft and this condition can cause the carbon to contact the shaft on clutch disengagement. This in turn can affect the synchromesh

action of the gearbox due to the shaft being "braked". It always pays to renew the front gearbox oil seal whenever this is accessible as they' only cost a couple of shillings but care should be taken not to damage the new seal by allowing the sharp splines on the constant pinion shaft to cut it as it is slid into position.

This can be overcome by wrapping some greasy brown paper around the shaft right up to and over the shoulder at the rear end. Also check the square headed taper bolts securing the fork and lever to the operating shaft in the gearbox as these can break or come loose thereby allowing the relationship of the parts to alter.

A sure sign of such trouble is when there is insufficient adjustment left on the clutch linkage even though the clutch plates and carbon are virtually unworn.

The most common gear change fault is an inability to move the lever from first to second gear and the basic reason for this lies in the gear change mechanism. What in fact occurs is that the gear lever is able to enter the

neutral gate before the selectors in the gearbox have been returned to their neutral position. The interlock mechanism in the gearbox then prevents any other gear except the one previously selected from being engaged. A number of points must be checked to overcome this condition and it may be found that attention to one or more of the following will be necessary.

Ensure that the four rubber bushes fitted at the top end of each operating rod are not impoverished or missing. In no circumstances should these rubbers be contaminated by oil, otherwise they will deteriorate rapidly, so take care when lubricating around the gear change mechanism on the steering column.

Make sure that the wire locked, square headed taper bolts securing the trunnions to the selector shafts on the gearbox are tight as they have a tendency to wear.

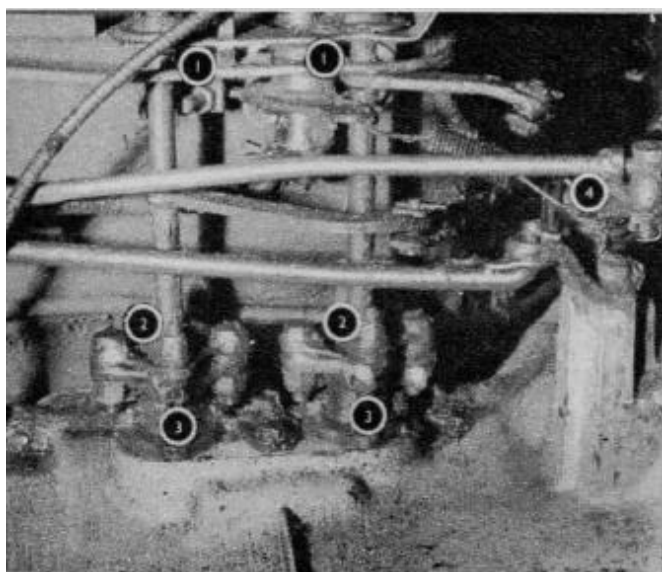

Wear-points on the gearbox. 1, the spherical bearing; 2, flexible transverse shaft couplings; 3, taper bolts on their trunnions and, 4, clutch adjustment point

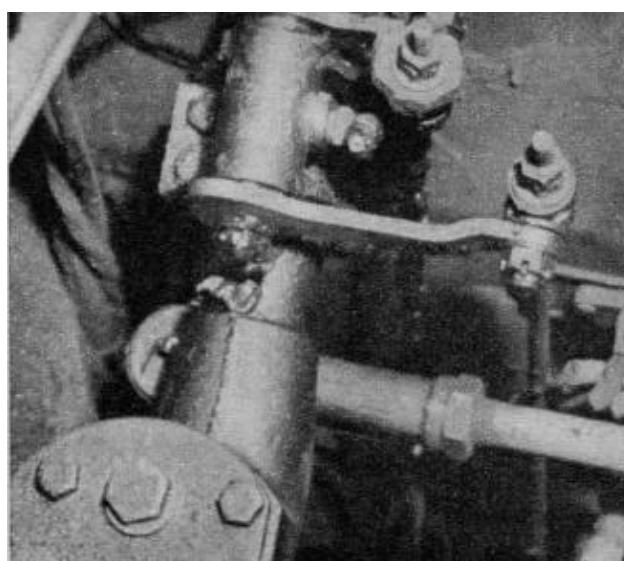

Close-up details of the gear-change adjustment on the steering column. Note the rubber bushes at the top of the rods—the one on the left is a D-I-Y product!

Check that there is no wear in the flexible strip type connectors fitted between the selector trunnions and the gear change transverse shafts. These are riveted to the shafts but in service new ones can be attached by bolts and locking nuts.

Renew the spherical bearings on the body which support the outer ends of the transverse shafts if worn. This is really a job for the garage as welding is involved but it is worth noting that there are two extra bearings fitted on the other side of the car for use on a left-hand drive vehicle and there is no reason why these should not be used as replacements.

After 30,000 miles, there may be sufficient wear in the rear road springs to allow the leaves a certain amount of sideways movement and this can result in the leaf immediately below the main leaf coming into contact with the rear shackle bracket. The result is a fairly heavy thump when cornering. The remedy is simple—you only have to remove the shackle bracket and grind or file away the excess metal at the point at which contact occurs.

Another unusual knock from the rear end is caused by contact between the offside shock absorber and the exhaust pipe clip and, here again, there should be marks to show the point of contact. The trouble is due to the clip on the exhaust pipe being positioned too far forward, but do not be misled by what appears to be bags of clearance as this reduces when the car is loaded.

The steering and front suspension on the Mayflower seem to be very robust and with the exception of shock



A mysterious noise can be caused after a large mileage by the rear-spring leaf hitting the hanger when the car is taking a corner at speed or heavily loaded

absorbers very little attention is normally required in the way of overhaul until very high mileages have been covered.

The steering box is fully adjustable in the following manner. Ensure that there is no end-float on the centre column and, if necessary, adjust this out by reducing the thickness of the shim pack fitted under the bottom cover plate. Backlash on the steering wheel is then reduced by setting the steering in its straight-ahead position, slackening the locking nut for the adjuster in the steering box top cover plate and then turning the adjuster clockwise.

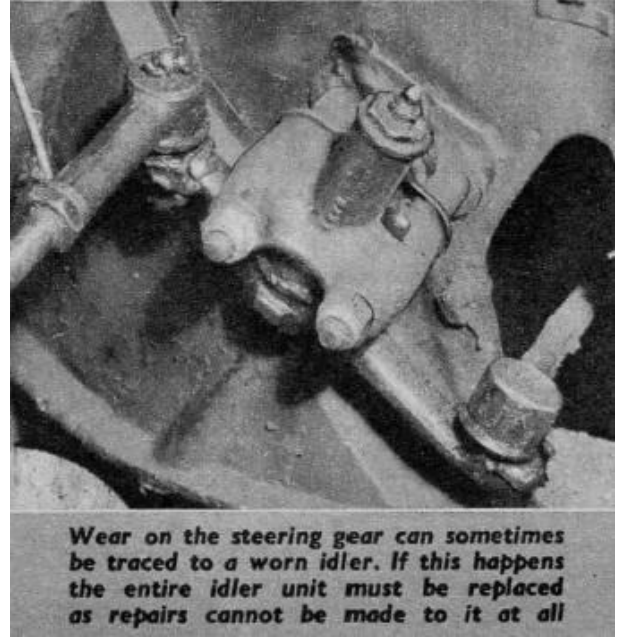
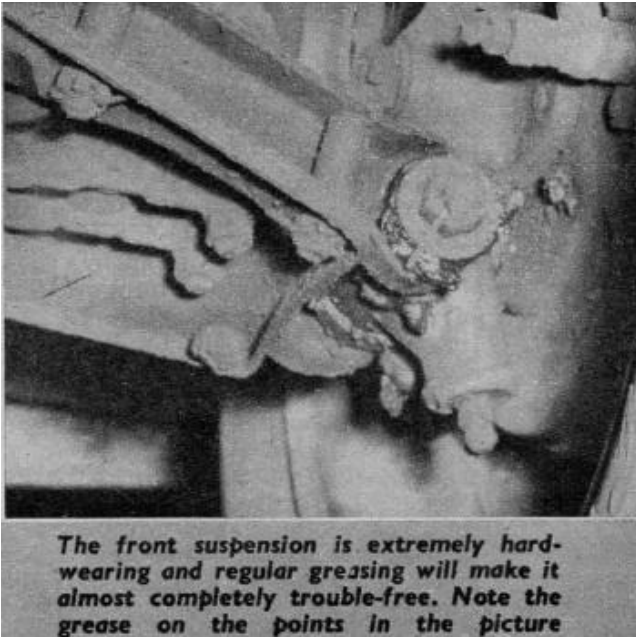

It is very important that this adjustment is not overdone otherwise the steering will become stiff and in time the box will be damaged. For this reason it is best to turn the adjuster as far as possible using finger pressure only. If the adjuster should be tight on its threads it is best to check results after each slight alteration. Correct adjustment is usually approximately half a turn of the adjuster back from its fully clockwise position.

Backlash or knocks in the steering can be caused by a worn slave lever. And as this cannot be serviced it will be necessary to replace the assembly. Such wear is obvious if the slave lever arm moves up and down as the steering wheel is moved back and forth.