

*Triumph  
Mayflower  
Club*

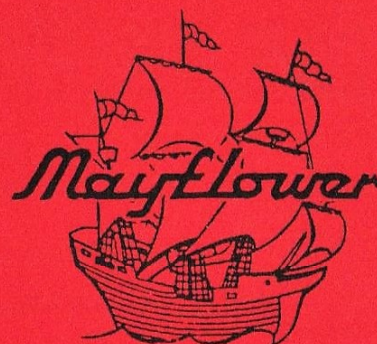

Worldwide Membership

WINTER ISSUE 2000 No. 98

*Merry  
Christmas*

*from all your  
Committee*

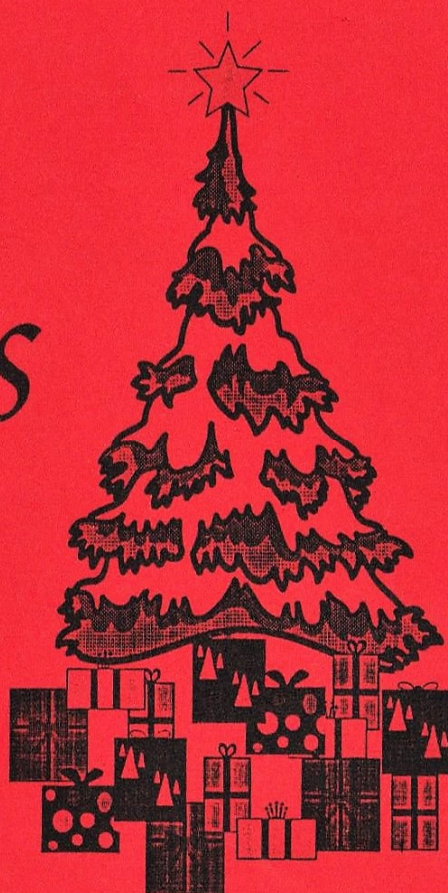

**FLOWER POWER**



# THE TRIUMPH MAYFLOWER CLUB

## Club Officials for 2000-2001

CHAIRMAN AND SECONDHAND SPARES	Peter Benfield, Amberley, Crintle Carr Lane, Thornton-le-Moor, Northallerton, N. Yorks DL7 9DZ
VICE CHAIRMAN	Tony Booth 1 Parkside, Hensington Gate Woodstock, OX20 1UR Tel: (01993) 811642
GENERAL AND MEMBERSHIP SECRETARY	John Oaker 19 Broadway North Walsall, West Midlands WS1 2QG Tel: (01922) 633042 E-mail: johnoaker@btinternet.com
NEW SPARES SECRETARY	John Gogay Cherry Hinton, Orchard Way Wilmington, Kent DA2 7ER Tel/Fax: (01322) 221493 E-mail: johngogay@breathe.com
TREASURER	Phil Benson 4 Dunlin Close, Redhill, Surrey RH1 5HJ Tel: (01737) 772202
RALLY SECRETARY	Howard Pryor 12 Park Road, High Barnet, Herts EN5 5SQ Tel: 020-8440 8623
EDITOR/SECONDHAND SPARES CO-ORDINATOR/ CLUB HISTORIAN	Steve Coulman 23 Park Street, Messingham Scunthorpe, S. Humberside DN17 3RU Tel: (01724) 762061 E-mail: stephencoulman@nicouls.globalnet.co.uk
ORDINARY MEMBER No. 1	Tony Thorpe
No. 2	Forbes Alexander
No. 3	David Miller
No. 4	Paul Norton

---

*When writing to a committee member and you require a reply, please enclose a  
Stamped Addressed Envelope*

*Please note that all the above committee members fulfil their positions in their spare time and not  
as a full-time occupation, so when contacting them other than by letter, please ensure that  
you choose a reasonable time of day*



# CONTENTS

EDITORIAL	Page 2 - 3
CHAIRMAN'S REPORT	Pages 4 - 5
2000 PLANNING MEETING	Pages 6 - 8
INTERNET MAGAZINE	Page 11
LETTERS	Pages 12 - 14
MORE ODDS AND . . .	Page 15
SPARE PARTS	Page 16

---

The information contained within Flower Power is the view of the writers and not necessarily those of the editor or the Mayflower Owners Club. Every effort is made to ensure the accuracy of the information contained, however use of such information is entirely at the members own risk and neither the club nor any individual shall in any way be liable for injury, loss or damage resulting directly from the use of such information.



## TRIUMPH MAYFLOWER CLUB SHIRTS SHORT-SLEEVED POLO & LONG-SLEEVED SWEAT SHIRTS

*WITH EMBROIDERED MAYFLOWER LOGO*

Available in Small, Medium, Large, Extra Large, and Extra Extra Large

*Colours available:*

Navy, Black, Red, Bottle Green, Emerald, Sky, White, Bright Yellow, Royal Blue, and Maroon

Prices: Polo Shirts — S/M/L £14 ExL/ExExL £15  
Sweat Shirts — S/M/L £16.50—ExL/ExExL £17.50

ORDER FROM THE SPARES SECRETARY

(Cheque with order please, made payable to Triumph Mayflower Club. Add £2 per garment for P&P)

Editorial**Well done Phil**

I WAS SADDENED to hear from Phil Benson that he was no longer able, due to personal and work commitments, to continue as Editor of *Flower Power*.

I know that Phil has a very busy life style and he must have deliberated long and hard over his decision. I will try and fill his boots and continue as sole editor.

Phil has been editor for the best part of seven years and in that period *Flower Power* has blossomed under his stewardship. The committee and members, old and new, thank him for his sterling work. Well done Phil! A tough act to follow.

This now leaves me with some work to do, and I don't intend to do it all on my own. Notwithstanding contributions by the committee and a regular group of members, submissions to *Flower Power* are generally far and few between.

**Your club**

I want you to prove me wrong! Shut me up! This is your club and your magazine so it's up to you to help me make it worthwhile. Don't just sit there and expect an informative and interesting read to land on your doorstep each quarter without some input.

You may feel that no one would be interested in your views and

technical knowledge, or that your grammar is not up to scratch — let the membership be the judge (I can always tweak here and there if absolutely necessary but will always avoid unnecessary tinkering). I hope that in the next issue I won't have to carry on in a similar vein.

You may recall the report of the passing of Steve Darley (161) in issue 94 and the hope that his immaculate Mayflower OUM 864 would go on loan to a suitable museum.

To date it still stands at home under cover in the garage. I contacted Gayden on behalf of his widow as they have virtually every Standard/Triumph on display, except that is a Mayflower.

**Free**

Frank Stoppard (825)  
is having a clear out and  
offers the following

**Free to  
whoever will  
collect them**

Gearbox, rear axle (without  
brakes), prop shaft, bonnet,  
boot lid, steering wheel and  
column

**Telephone:****01207 542218**



Due to the takeover by Ford and the uncertainty of the Dagenham collection the offer of a long-term loan was respectfully refused on the grounds of lack of space — hmmm!

### Research

I contacted Gayden with regard to continuing my research into the Mayflower in their photo-archive and was told that the archive had been closed indefinitely due to damage/theft (can you believe it!).

In time (no date given) the archive will be re-opened on a computer database which should allow easy scrutiny. Personally I

like to hold what I'm looking at (oh-er Matron) but fully understand the decision to protect the archive.

I have made a list of photographs of the Mayflower from previous visits and hope that if needed a print could be obtained.

There are literally hundreds of photos of the Mayflower in the archive covering every aspect, even before the launch on 26th September 1949.

Well, time to sign off. Merry Christmas and a Happy New Year to you from myself and all your Committee. Cheers!

## 1953 TRIUMPH MAYFLOWER

Black, with red leather interior  
Restored 5 years ago, all re-chromed, needs  
minor work, ideal winter project  
Original registration

£1,295 ono

Tunbridge Wells - Tel: 01892 824038

## MAYFLOWER FOR RESTORATION OR SPARES

£325

Tel. Maidstone 01622 831871



# Chairman's report

I FEEL I must begin my winter remarks by congratulating Phil Benson, together with John Gogay, for a superb autumn edition of *Flower Power*.

This colour edition, which we hope to repeat each autumn, was received favourably by members and was a most creditable publication for a club with quite limited membership.

Contributions from members attending the rally made refreshing reading, reflecting the appreciation of the committees efforts and thus making the editor's job so much more satisfying (more please — Ed). Reader's contributions are always welcome to help give the magazine a more family flavour.

## Weather

On reflection the summer weather (in the UK) didn't provide classic car enthusiasts with much to cheer about — countless weekends seemed to be rain affected and the September fuel shortage (in the UK) made some rallies a risky business with the uncertainty of future petrol purchase for the return journey.

These two factors made me reluctantly withdraw from events at Glamis and Sunderland Hall, Selkirk in the Scottish Borders.

## FOR SALE

Workshop manual  
£30

Drivers handbook  
(no cover) 2nd Edition

Sales brochure  
Gearbox, spare wheel  
Odds and ends

Contact:  
John Blundell  
Southport, Wigan  
Tel: 01659 721130

Now that petrol supplies have returned to normal most people will have made decisions as to the additives they have chosen while some fortunate enough to live near a Thrust outlet can of course carry on with original leaded four star, but at quite a high price.

Each club member will have made their own choice — comments of any detrimental 'knock on' effects would of course be appreciated.

Living close to a Thrust outlet did mean that during the fuel shortage I was able to make use of my Mayflower and thus avoid any inconvenience during every day motoring.

My winter projects are to have some repairs and renovation work on the leather of my front seating together with re-chroming of the nearside window surround.



Hopefully I will be able to take out the surround all in one piece, dismantle it and with a little luck be able to put it back together again.

I seem to have sorted out my rear springs after much trial and error. The rear end was riding quite high, probably because of mere friction from the flat leaves, the original leaf with a groove down the middle is apparently no longer manufactured.

I found, eventually, that by using the top two leaves from the new spring together with the older leaves has not only brought the rear end level but has also stiffened

the rear suspension, with the benefit of much less roll when cornering.

I am writing these notes just before our second November Planning Meeting and I can assure you the committee will endeavour to make all future rallies as enjoyable as the last three.

All helpful suggestions from members are welcome before final decisions are made at the March 2001 AGM.

Meanwhile best wishes to you all for Christmas and the New Year and your winter Mayflower motoring!

## **1953 Triumph Mayflower**

**Maroon with excellent body and chrome  
New exhaust and clutch. Engine rebuilt  
Tax and tested**

**Sale due to ill health**

**Telephone: David Dorrens (878)  
(Glasgow) 01355 234311**

## **WANTED**

**MILL BOARD FOR PARCEL SHELF  
on drivers side (RH drive), any colour**

**Barry Precious - 01482 865667**



# 2000 Planning Meeting

THE MEETING was held at Alumwell Junior School, Walsall on Sunday 26th November at 2.00 pm. Present: John Oaker, Peter Benfield, Peter Benson, Howard Pryor, Tony Booth, Dave Miller, Ben miller, Paul Norton, Norman ward, Tony Thorpe, Stephen Coulman Apologises: John Gogay.

Peter Benfield welcomed everyone to the meeting and thanked John Oaker for arranging the venue and refreshments.

Howard Pryor made two presentations. Firstly to Peter Benfield with a framed photo of the celebratory cake that Sue Benfield had provided for the 25th anniversary rally at Bletchley Park (very tasty — *Ed*).

Secondly to Tony Thorpe for his top five car award from Bletchley Park after Tony had to leave early to get his son home in time for a drama rehearsal — kids! I believe Tony is the only member to have received the Forbes Alexander Award and a 'concours' award back to back.

Howard Pryor said that he believed the 2000 Rally had been a great success and said he had received many favourable comments. This was echoed by

those in attendance. Peter Benfield gave his and the Club's thanks to Howard for his work on the rally.

Howard then updated the committee on latest arrangements for the 2001 Rally.

It will be held on 1st July 2001 at Buckinghamshire Railway Centre, Quanton near Aylesbury. It will be held in conjunction with the Pre 1940 Triumphs and Triumph Roadster clubs.

The Triumph Razoredge Owners Club has yet to make a decision on their attendance. *Make a note of the date in your diary!*

Howard is still investigating local hotels and arranging the Saturday evening festivities for those who wish to make a weekend of it. More details in the next issue of *Flower Power*.

Suggestions for the 2002 venue are now being sought from the membership, i.e. you!

Have you been somewhere that you think might make a suitable venue for our club rally? Why not nominate it! Please bear in mind the following brief guidelines:

**WANTED**  
**Fuel Pump  
Operating Rod**

Brad Khaler, USA  
Email [brad.khaler@141.com](mailto:brad.khaler@141.com)  
or contact  
Stephen Coulman



**WANTED**

**Air Filter  
and  
Carburettor**

Al Adams  
23 Rochelle Street, Brandon  
MS 39047 8470, USA  
or contact Stephen Coulman

Parking for 100 classic Triumphs, 50+ modern cars, 30-45 visiting classics.

Space for five autojumble stands etc.

Space for our central tent/marquee and four gazebos, barbecue etc.

Please send details and information to Howard Pryor only after you have satisfied yourself that your suggestion meets the above criteria.

### Secondhand spares

Peter Benfield has taken some of the secondhand spares, but by no means all, of the spares held by Jim Smethurst. He is happy to 'house' the rest and the £400 bank balance in the secondhand spares account. This was seconded by Stephen Coulman and carried by the meeting.

It was agreed that committee and club members be called upon to help Peter relocate the

remainder of the spares in the near future.

Stephen Coulman once again asked that members send him details of the spares that they hold so that a database could be set up to marry needs and for sales etc.

Previous requests had so far produced little fruit.

### New spares

It was agreed that, space permitting, John Gogay should provide a list of new spares held by the club in each issue of *Flower Power*.

It will probably be sections at a time, i.e. engine, brakes, etc. This will let members know exactly what is available and give feedback on what needs to be sought/remanufactured.

Members should contact John direct. The committee extends its thanks to John for all his hard work over the years finding 'new' spares and arranging remanufacture etc.

**1953 Triumph  
Mayflower  
For Sale**

Complete, Black  
Original number. Some spares

£300 or offers

Contact: David Ross  
Tel 01440 702472  
Cambs/Suffolk borders



## Flower Power

Stephen Coulman agreed to become sole editor. All correspondence for inclusion in *Flower Power* should now be addressed to him alone. Phil Benson's contribution as editor over the past seven years was acknowledged and thanks given.

It was agreed that Phil's swansong should be the 100th edition of *Flower Power*, possibly in full colour, dependent on cost. Please send any ideas or contributions now.

## Website

Phil Benson is to concentrate his efforts on the club's fledgling website.

## Treasurer

Phil Benson will hold the post of Treasurer until March 2001. Nominations for this post are now being accepted for the March 2001 AGM. Why don't you stand? Give Phil a call to discuss the post.

## Forbes Alexander Trophy

The trophy is for the saddest looking Mayflower at the rally. It was agreed that a £20 spares voucher be given with this award to help the recipient in restoring their car.

Howard Pryor has had key fobs and badges made with the club logo on. Contact John Gogay for details etc.

## WANTED

**Wheel nut  
wrench/brace**

**Original tool roll  
and contents**

**Overriders (front  
and back)**

Contact:

Terry Sanders  
Post 1, Box 16  
499 Embarcadero, Oakland  
CA 94606, USA  
Fax number: 1-510-487-0866

**YOU CAN  
ADVERTISE IN  
FLOWER  
POWER  
FOR FREE**

*Just send your  
advertisement to  
The Editor*



# Fuel Storage Regulations (UK)

DURING THE recent fuel shortages in many parts of the UK people were filling up all sorts of unsafe fuel containers, perhaps unaware of the low legal maximum limit of such storage and the risks they ran, or they were just stupid and selfish?

The limit is two x 10 litres in approved metal containers or two x 5 litres in approved plastic containers stored in an area separated from any living space by a half-hour fire resisting structure. The screw and closure cap on the approved containers must be secured tightly to prevent escape of vapour.

The source of this requirement is the Petroleum Spirit (Motor Vehicles) Regulations 1929/952, as amended by the Petroleum Spirit (Plastic Containers) Regulations 1982/630.

I am fortunate to have two garages selling leaded four star within 12 miles of my home. However, I've found that the 'new' four star is more like five star and had initial running problems before I weakened off the mixture considerably. Worth bearing in mind if you intend to put the odd tank of the 'old juice' in from time to time.

How are you coping with additives? Are you using LRP? Share your experiences with fellow members, good and bad.

*Please remember don't hoard petrol at any time!!*



## 1952 TRIUMPH MAFLOWER

Comet blue with blue leather interior. Excellent chromework, stainless exhaust. Owned 22 years. New car reason for sale. MoT etc

**TELEPHONE: 01322 221493**



# The 3rd practical CLASSICS GREAT BRITISH AUTOJUMBLE

## THE PLACE TO FIND THAT ELUSIVE PART...

WHATEVER THE WEATHER - AIR CONDITIONED - ALL FACILITIES!

660 STANDS

Visit our website at:

[www.classiccarshow.co.uk](http://www.classiccarshow.co.uk)



"What a great way to start the year! Tons of stuff to help with my restoration - from books and rare spares to tools for the job, even sound advice - all under one roof. It was well worth the journey."

Coeff Marsden  
Carlisle

SUNDAY  
7<sup>TH</sup> JANUARY  
2001

THE NEC,  
BIRMINGHAM  
10.00am-5.00pm

£6.50 ENTRY  
FREE PARKING



BE AN  
AUTOJUMBLER

With a friend or club colleague.  
Space only £55  
Ring Andy on  
0121 767 2772

"empty the garage"

TICKET  
HOTLINE:

0121  
767  
4848\*

\*Transaction fee:  
50p per booking



# New Internet Magazine launched

JOHN MACARTNEY, a former Standard Triumph employee will be launching an email 'ezine' in January 2001 dedicated to former Standard and Triumph products and how they are being used and enjoyed throughout the world.

Uptake for this new publication, which will only be available as an email attachment for registered subscribers currently in North America, Europe, South Africa and Australia/New Zealand has greatly exceeded his expectations.

It is planned for six issues to be released annually and subscribers are encouraged to submit their articles and views in any language.

This facility seems to have been welcomed from enthusiasts in mainland Europe who do not have English as their mother tongue and serves to underline the objective of having a truly global publication.

The annual subscription is £10.00 (US\$15.00) for six issues and a condensed evaluation copy is available for enthusiasts who wish to 'try before they buy'.

New subscribers who join during any one year will automatically receive back issues for that particular subscription period.

The 'ezine' uses the company's former telegraphic address 'Flywheel Coventry' as its name and is only available from John MacCartney at [jonmac@ndirect.co.uk](mailto:jonmac@ndirect.co.uk)

## Internet

The Internet holds no bars — recent email received by Stephen Coulman reads:

Urgent! Got a call last night, Southern California movie studio looking for a London taxi or right hand drive Triumph Mayflower. I just completed a left hand drive Mayflower. But may not be able to use left hand, they are shooting a Wimbledon scene. Need to respond back to them before Monday cut off date.

Fred Perry had a two tone Mayflower, registration MVC 148, black over cream I believe. That would have been ideal!

## WANTED

# Door and Boot Handles

Chrome must be good  
and not pitted please

Contact:

Frank Stoppard

Telephone: 01207 542218



Letters**Whereabouts of  
Mayflower NXB 521**

Dear Stephen,

My reason for contacting you is quite simple, some years ago I owned a Mayflower, and I would love to know if it still exists. I bought NXB 521 from a retired bank manager in Surbiton. The car was formerly owned by his father since it was only two years old and when I bought it about 18 years ago had covered a genuine 40,704 miles. It was black with a red interior and although it needed a respray was complete and running. I had some welding done and it was a very solid little car. My wife hated the Mayflower, she said it looked like a taxi, and when I later bought a Daimler Dart I sold it to a friend here in Newport Pagnell on the basis that the car would be finished and used. Sadly not the case, he in turn sold it to another local chap for his son and again it was not finished. You can imagine my horror the day I saw my car parked outside Goodmans our local scrapyard. The car was then acquired by Maestro Coachworks in Milton Keynes who intended to restore it and presumably sell it. They ceased trading sometime ago. If anyone known to the club knows of or indeed owns NXB 521 I would love to hear. I may be able to

help fill in the gaps in its past history.

Finally, if the club member who I met at the Stoke Goldington Steam Rally a few years ago when he was exhibiting his dark green Mayflower, and I sent him a mint owners handbook on the promise of a bottle of Autoglym polish as a straight swap, would care to remember, I would love to receive the Autoglym.

*Received via the Club's website  
from non-club member  
Esmond Tearle, 47 Westbury Lane,  
Newport Pagnell, Bucks MK16 8PN  
Tel. 01908-616644*

**New member starts  
in at the deep end**

Dear John,

Re our conversation I have completed the application form and enclose some photos (see page 13). Unfortunately the garage that the Mayflower is in is full of Mk II Cortina spares, as you can probably see.

YMV 276 came to be in my possession after meeting my Uncle

**Photos and details  
of your Mayflowering  
experiences for  
Flower Power**

*Contact:*  
Steve Coulman



Colin, who I hadn't seen for some time. After chatting for a while over a few pints the conversation turned to the petrol-heads in our family, a few owning classic cars.

After telling Colin about my collection of Mk II Cortinas he told me about YMV 276 and offered it to me, and of course I said 'yes'.

A friend and I went to collect it with a flatbed and found it sat in the garage covered in dust. A front wheel was missing but after re-fitting it was winched aboard the truck.

My uncle told me he bought the car in 1982 from a garage in

Benfleet, the owner of which had had it for three years having acquired it from the original owner who took it in for repairs and never came back!

My Uncle's idea had been to restore it but travelling back and forth to the car got the better of him. The car is now in my hands and I am trying to retrieve the original registration number from the DVLA, with help from the Club, before I start the restoration. Fortunately for me the car is complete, which is more than can be said for my previous restoration projects.

*John Robinson (908)*

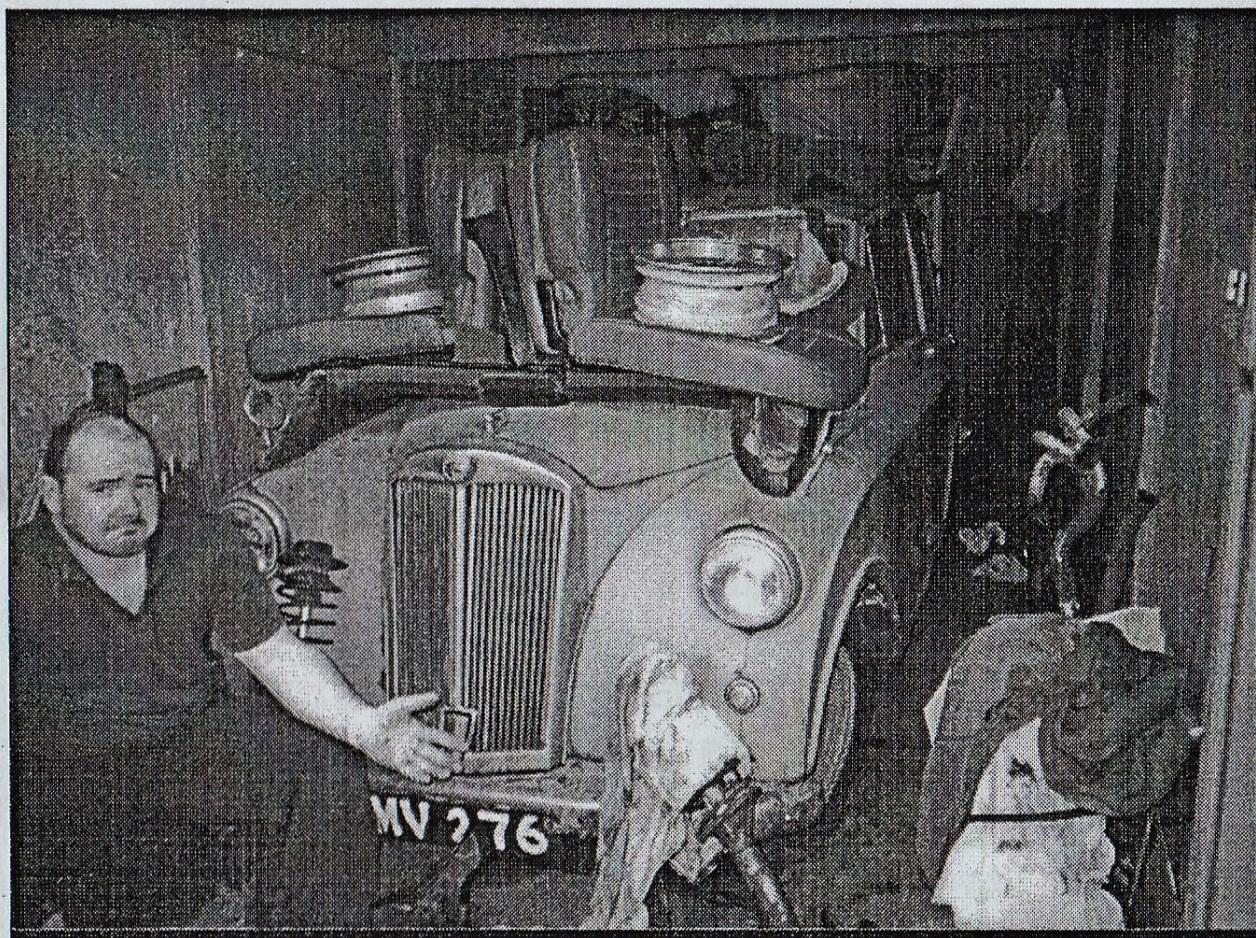

*Am I mad or what?*



## Memories of 'real life Mayflowering'

Dear Stephen,

I bought my Mayflower while I was a student at St John's College, York. I got it from a garage in Acomb, York around 1966 and paid, I think, £50. The interior was magnificent — the wooden dash and comfortable leather seats.

With my limited knowledge of engines, I failed to realise the significance of double plug extensions. On a journey from York to Normanby, near Middlesborough, a distance of 50 miles the car used a gallon of oil.

I used the thickest grade of oil and the engine used to over-heat

after about 35 miles. After the first scare I always went equipped with spare oil and water. In 1967 I part-exchanged the car to another York garage and got about £15 for it!!

The car had been brush-painted a bright blue and was my idea of motoring luxury!

*Received via the Club's website from Dave Brearley a non-club member*

*(Alas, no wood dash as the Mayflower was already too expensive to rival it's intended competitors. I have seen a painted wood fascia on a Mayflower and I must say it did look a treat. Has anyone got a photo to put in Flower Power? - Ed)*

# 1953 TRIUMPH MAYFLOWER FOR SALE

in primer after total body rebuild  
including new floor

Stainless steel exhaust. Reconditioned engine  
New petrol tank. Needs finishing

Contact:

Peter Fitzjohn, Canterbury

Telephone: 01304 812168

## More Odds and . . .

### AA Club membership discount

Did you know that you can get a discounted rate for your first years membership of the AA as a TM Club member? Telephone 08705 444222, quoting reference 315509, for information in detail.

### Auto fest

Auto Fest is back again next year with a vengeance, to be held at Morden Park on Sunday 29th July 2001. Details to follow so watch this space or contact David Stafford at [david.stafford@kvaerner.com](mailto:david.stafford@kvaerner.com)

### Standard/Triumph Marque day

Sunday 27th May 2001 (UK Bank Holiday) at the Heritage Motor Centre, Gayden, Warwickshire. Details to follow so watch this space.

### Trivia

Dave Chanley became the British Light Middleweight Champion (boxing) in 1952. What did he buy

with part of his prize money? — You guessed it! — a brand new Mayflower. He may have still been punch drunk!!

### Mr. M. Whitfield, director and general manager at Standard Triumph on Sir John Black

“He has a wonderful bent for seeing the worth of a man, even when the man himself does not know he has it in him.

I was a shy and miserable boy but he drew me out and urged me on, as he has done with thousands of others. You couldn't find a better boss.

When there's a big post to be filled in the factory, he makes the point of seeing that it is filled by men who have been with us since apprenticeship days. His greatest power is that if you are wrong he'll chew you up, but he'll never loose your friendship.

If you are wrong and go and tell him you're wrong, he'll say: 'Sit down and let's sort this out.' Mark you, if he finds out for himself, you get a different treatment!”



## NEW PARTS — ENGINE

	Quantity per car	Part No.	Equivalent Nos.	Price (each)
Pistons, standard size . . . . .	4	101215		25.00
Pistons, set of 4 (*1) . . . . .	1	101215		120.00
Piston Ring Set, 3-ring piston (*2) . . . . .	1		Cords 30	32.00
Piston Ring Set, 4-ring piston (*3) . . . . .	1		Cords 30R	40.00
Main Bearing Set (*4) . . . . .	1	100325/6	Vandervell VP431	46.00
Big End (Con Rod) Bearing Set (*4a)	1	100461	Vandervell VP430	34.00
Timing Chain	1	44101		9.00
Timing Chain Wheel	1	35960		39.00
Timing Chain Tensioner	1	42425		6.50
Timing Chain Oil Seal	1	100499		5.10
Timing Chain Locking Plate	1	36411		1.10
Timing Chain Cover	1	200101		25.00
Starter Ring Gear, flywheel (*5)	1	201350		46.00
Locking Plate, flywheel	2	102076		1.10
Core Plug, rear of engine	1	58845		1.50
Core Plug	4	102970		1.30
Spiral Gear	1	102337		36.00
Inlet Valve	4	100363		7.90
Exhaust Valve	4	100364		7.90
Valve Guide	8	100862		3.80
Valve Spring	8	47757	Terry/Aero VS295	3.20
Front Engine Mounting, pair (*6)	1	200662/3	TMC6	11.00
Crankshaft Chain Wheel	1	100431		31.00
Oil Deflector, crankshaft	1	100447		1.90
Head Gasket	1	200175		29.00
Cylinder Head Stud	16			1.20
Gasket, engine rear plate	1	200097		1.20
Gasket, engine front plate	1	200091		1.20
Gasket, timing cover	1	200102		3.40
Gasket, sump	1	200623		3.75
Gasket, tappet cover	1	43669		3.80
Gudgeon Pin Bush	4	100798		2.90
Anchor Plate, tensioner, timing chain	1	43752		0.80
Anchor Pin, tensioner, timing chain	1	33214		0.90
Bush, crankshaft	1	47246		3.30
Valve Nut, tappet cover	1	60899		1.40
Starter Jaw	1	100348		16.00
Oil Retaining Cover	1	100353		28.00

### Tools for Hire

Cylinder Head Removing Tool (fits in sparking plug holes, includes £10.00 deposit)	14.00
--	-------

(\*1) Set includes gudgeon pins and circlips. Sizes available: Standard; 0.020"; 0.040"; 0.060". (\*2) Sizes available: 0.010"; 0.020"; 0.030"; 0.040"; 0.060". (\*3) Most sizes available. (\*4) Most sizes available. (\*4a) Most sizes available. (\*5) Must have detachable flywheel. (\*6) For use with original backplates.



# Classic Car Sills

Parts for the Triumph Mayflower

Ken  
Teleph



SILL £20.00



FRONT  
APRON £45.00

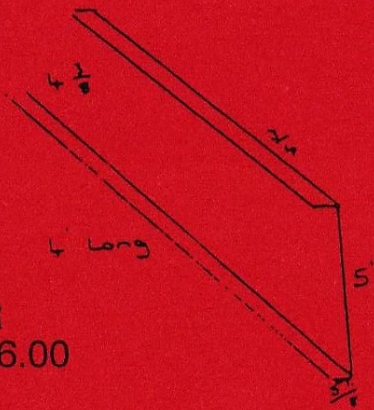

INNER  
SILL £6.00

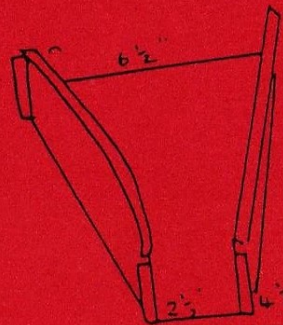

OUTRIGGER  
£7.50

INNER SILL £20.00

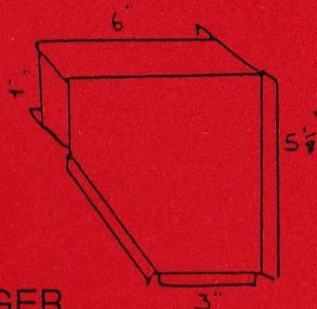

OUTRIGGER  
£7.50

REAR SPRING  
CHASSIS  
£7.50



**J. COLLIER**

4 Mortimer Road, Kempston, Bedford MK42 8RE  
Tel: 01234 840958 (Evenings) or 01480 477530 (Works)



