

Triumph Mayflower Club

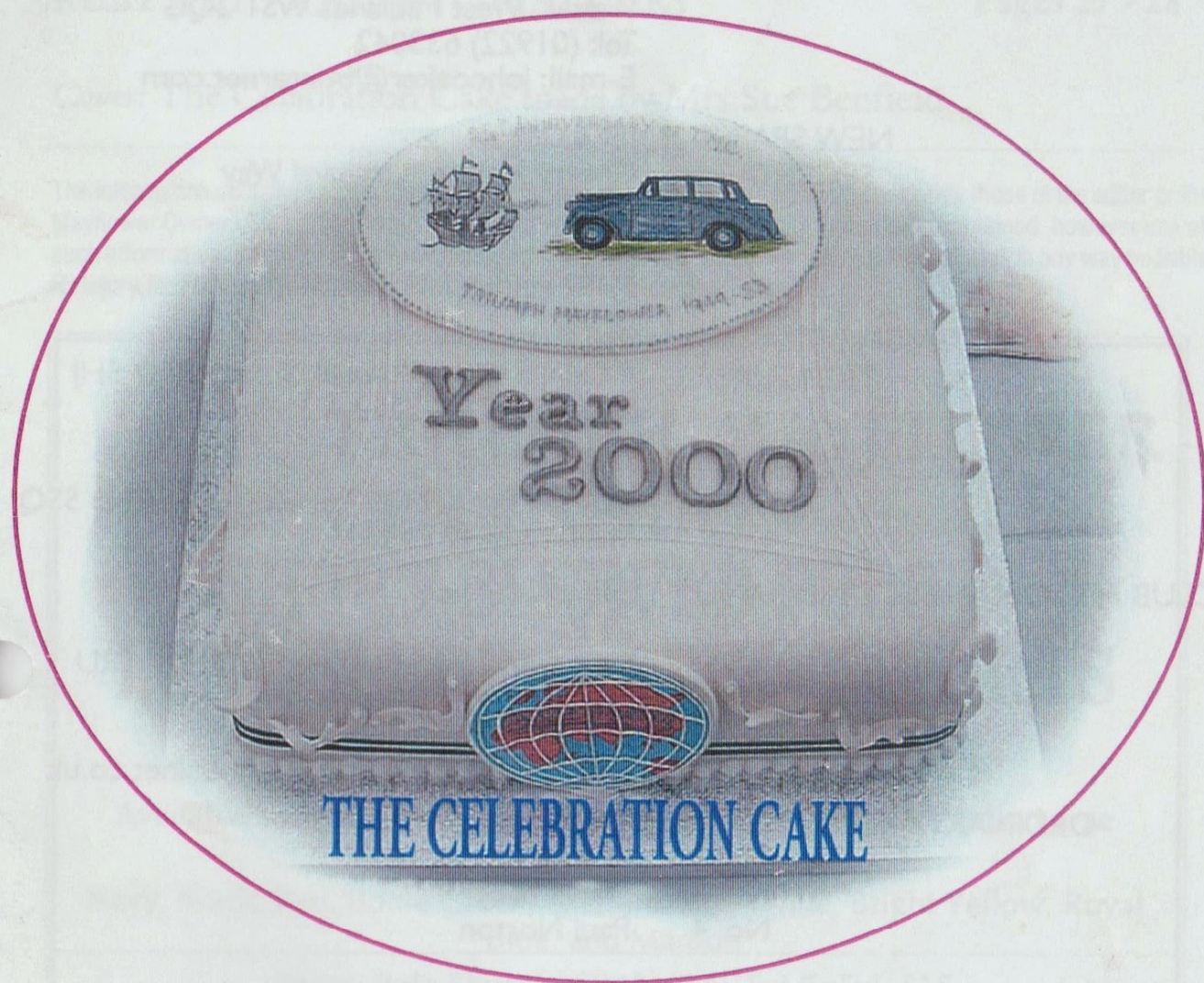

Worldwide Membership

AUTUMN ISSUE 2000 No. 97



FLOWER POWER

THE TRIUMPH MAYFLOWER CLUB

Club Officials for 2000-2001

| | |
|---|---|
| CHAIRMAN | Peter Benfield, Amberley, Crintle Carr Lane, Thornton-le-Moor, Northallerton, N. Yorks DL7 9DZ |
| VICE CHAIRMAN | Tony Booth 1 Parkside, Hensington Gate Woodstock, OX20 1UR Tel: (01993) 811642 |
| GENERAL AND MEMBERSHIP SECRETARY | John Oaker 19 Broadway North Walsall, West Midlands WS1 2QG Tel: (01922) 633042 E-mail: johnoaker@btinternet.com |
| NEW SPARES SECRETARY | John Gogay Cherry Hinton, Orchard Way Wilmington, Kent DA2 7ER Tel/Fax: (01322) 221493 E-mail: johngogay@breathe.com |
| MAGAZINE EDITOR/ TREASURER | Phil Benson 4 Dunlin Close, Redhill, Surrey RH1 5HJ Tel: (01737) 772202 |
| RALLY SECRETARY | Howard Pryor 12 Park Road, High Barnet, Herts EN5 5SQ Tel: 020-8440 8623 |
| CLUB HISTORIAN/SECONDHAND SPARES CO-ORDINATOR/ JOINT EDITOR | Steve Coulman 23 Park Street, Messingham Scunthorpe, S. Humberside DN17 3RU Tel: (01724) 762061 E-mail: stephencoulman@nicouls.globalnet.co.uk |
| ORDINARY MEMBER No. 1 | Tony Thorpe |
| No. 2 | Forbes Alexander |
| No. 3 | David Miller |
| No. 4 | Paul Norton |

*When writing to a committee member and you require a reply, please enclose a
Stamped Addressed Envelope*

*Please note that all the above committee members fulfil their positions in their spare time and not
as a full-time occupation, so when contacting them other than by letter, please ensure that
you choose a reasonable time of day*

CONTENTS

| | |
|-----------------------------|---------------|
| EDITORIAL | Page 2 - 3 |
| CHAIRMAN'S REPORT | Pages 4 - 5 |
| RALLY REPORT | Pages 6 - 10 |
| BLETCHLEY 2000 REPORT | Pages 11 - 12 |
| RALLY DISASTERS | Pages 13 - 14 |
| LETTERS | Pages 15 - 21 |
| RAMBLING AROUND | Pages 22 - 23 |
| WHAT A NIGHT | Page 24 |
| FBHV NEWS | Pages 25 - 26 |
| RUBY GETS A LIFT TO MALLORY | Pages 27 - 28 |

Cover: The Celebration Cake made by Mrs Sue Benfield

The information contained within Flower Power is the view of the writers and not necessarily those of the editor or the Mayflower Owners Club. Every effort is made to ensure the accuracy of the information contained, however use of such information is entirely at the members own risk and neither the club nor any individual shall in any way be liable for injury, loss or damage resulting directly from the use of such information.



TRIUMPH MAYFLOWER CLUB SHIRTS SHORT-SLEEVED POLO & LONG-SLEEVED SWEAT SHIRTS

WITH EMBROIDERED MAYFLOWER LOGO

Available in Small, Medium, Large, Extra Large, and Extra Extra Large

Colours available:

Navy, Black, Red, Bottle Green, Emerald, Sky, White, Bright Yellow, Royal Blue, and Maroon

Prices: Polo Shirts — S/M/L £14 ExL/ExExL £15
Sweat Shirts — S/M/L £16.50—ExL/ExExL £17.50

ORDER FROM THE SPARES SECRETARY

(Cheque with order please, made payable to Triumph Mayflower Club. Add £2 per garment for P&P)

*Editorial***Any volunteers**

THE RALLY proved yet again to be a huge success. There are numerous reports about the day elsewhere in the magazine so I will restrict myself to saying "Congratulations and Well Done" to everyone who contributed before or on the day to making it so enjoyable for us all.

Petrol issues have taken a new turn — last year we were all wondering whether we would be able to get 'leaded' petrol for much longer and if the Lead Replacement Petrol would be satisfactory or not.

We survived that and by all account most of us now use unleaded with an additive in our Mayflowers.

Blockades

Recently we have been watching the refineries in France, Belgium and Great Britain be blockaded, bringing us all to a halt and putting democratic governments under pressure. Never a dull moment is there.

I have not made much use of JBD 807 this year. First of all we failed the annual MoT test in May on a leaking brake master cylinder. I rebuilt it and we got a pass second time round.

After that we went to about four local rallies and the Annual Rally during June and July but with a

**Great British
Autojumble**

Sunday
January 7th
2001

*The National
Exhibition Centre
Birmingham*

Over 500 stalls last year
Space for nearly 1000 allowed
for this year. Make this the first
date in your diary for next year

weeks holiday away at the start of August and another week away at the end of August we did not have chance to do any more.

Now the rain

The wet weather is now upon us and winter feels it has started early here this year. Redhill was the wettest place in the UK as it had a month's normal rain in a day last Friday with thunder and lightning to boot.

My car port floor is concrete and I painted it a nice red colour during the summer — it is now muddy brown so I will have to wash it down at the weekend. At least the garage did not flood but it was mighty close.

The best local rally was at the "Lavender Line" railway near Uckfield in Sussex. It was a small but very friendly affair and with free rides on the trains up the mile or so of track behind a little 0-6-0 tank engine. Steam traction engines, a small funfair, home brewed cider on sale and bright sunshine all day who could want for more.

The Website has been up and running since January but I have not had much chance to make much progress or even to keep it up to date recently.

Editorship

I am doing a very large project at work and time is at a premium. There is a very good chance that I will be giving up my positions as Editor and Treasurer at the next AGM so if anyone is interested in either job please let the committee know or give me a ring to discuss them.

The Treasurer's job is fairly easy to handle as everything is set up on an Excel spreadsheet and the Spares account is totally managed by the spares secretary as a separate area. The Editor's job is split between Steve Coulman and myself. We are doing alternate magazines. This will have to be reviewed if necessary.

We normally put photographs of members' cars in when they are sent in with articles or when they get taken at the National Rally. This means that lots of you have

never had a photograph of your car published. Why not send in a photo — a few words too would be nice, but not essential.

You can even send me photos of restorations in progress or whatever, anything will be considered, remember a picture is worth a thousand words.



The Chairman's wife, Sue, with the splendid cake she made

Anyone who has not yet paid their

Annual Subscriptions

will not receive any further issues of Flower Power or be able to purchase spare parts from the club

Make sure you've paid

(see envelope)

Chairman's autumn report

IN MY official capacity as the Chairman of the Club I would like to thank all owners and friends who participated in the 2000 Rally for helping to make this a very special occasion.

There are several reports of the rally in the magazine, including one that I have produced. I had hoped that our numbers might have reached the magic figure of 20 this year, unfortunately bad luck meant that Don Butler had to leave his Mayflower behind, otherwise we would have achieved this goal this year.

The day was a great success and not only brought together the oldest and the youngest Mayflowers known to the club, but also enabled us to welcome Mr and Mrs Reg Varney.

Reg is one of the club's founder members, so it was fitting that his wife should cut our 25th Anniversary celebration cake. We sincerely hope to see them again at future rallies.

For my part there seemed so much to see but so little time to view the attractions on offer. Our 1950s Rear Seat Memorabilia Competition created much interest and we were delighted to have Mrs George Jeary and family to judge this contest.

Roger Turpin's authentic Naffi van helped to create a 1950s atmosphere, we appreciated his presence and his enthusiasm and hope he will be with us in 2001 in his restored Mayflower.

Once again our raffle and tombola ladies deserve our thanks for their sterling work. I am sure we all drove away from Bletchley Park with some sadness that such an enjoyable day had to come to a close.

My own travels in 2000 have taken me to Mellerstain House in the Scottish Borders where I met up once more with Ian Watt from Edinburgh.

The "Fun Run" on the Saturday afternoon explored Walter Scott country finishing at his home, Abbotsford House, just outside Melrose. For those who do not remember the name, he was the author of several wonderful novels including the well known *Kidnapped*.

The weather deteriorated overnight spoiling the Sunday gathering otherwise we would have had five Mayflowers present.

In the middle of July I also visited Newby Hall as a spectator, probably the best ever show staged there, with a most comprehensive autojumble.

I picked up two fan belts for £5 and a set of contact points for the same price along with some new inlet and exhaust valves for reasonable money.

As I am in the process of overhauling a spare engine the latter will come in useful. I have had the head on this block skimmed and hardened valve seats inserted before re-cutting of the seats.

I had not previously thought this was possible on our side valve blocks and was quite surprised that this could be done. There is also less chance of them coming out on a side valve engine, they would of course drop down on to the valve on an overhead valve engine and create much damage.

All my preparations are a precaution for the future in case any long-term damage becomes

apparent in my present engine some time in the future.

For watchers of the TV programme "Heartbeat" in the autumn you may catch a glimpse of a Mayflower in episode 4, filmed between 10 pm and 3 am in front of Constable Hall, North Yorkshire.

In conclusion I hope all members have enjoyed using their cars this summer in spite of weather inconsistencies and of course the high price of UK petrol which does now impact on one's pocket and probably makes some of us use our cars a bit more selectively.

Peter Benfield, Chairman

FOR SALE 1953 TRIUMPH MAYFLOWER

Lovingly restored over three years to a very high standard
Engine, Gearbox and back axle rebuilt
New wiring loom fitted

All shiny parts re-chromed including window frames
All rubbers replaced with new

Resprayed in Maroon with tan leather interior
New tyres fitted

Only covered 800 miles since the restoration was completed
Full photograph and video of the restoration

Cup Winner at the 1998 Ipswich to Felixstowe Rally

Offers in the region of £3,500

Contact:

Dave Seaden Tel: 01206 - 823764

44 Lucerne Road, Elmstead Market, Colchester, Essex CO7 7YM

Rally report

by Howard Pryor, Rally Secretary

THIS YEAR the sun shone for our annual rally, with most weekends previously being very wet we were most fortunate. This was the start of a very good rally, perhaps the best yet, with the added attractions of Bletchley Park itself.

Vehicles present this year included 19 Mayflowers; 45 Roadsters; 35 Pre-1940s; nine Renowns and one Naffi van (which provided much needed refreshments during the day).

Members attending with their cars this year were: Brian Barker;

Peter Benfield; Phil Benson; Steve Coulman; John Gogay; Helen Hunter; Pat McKeefry; Ken MacKenzie; Ben Miller; Dave Miller; Chris Naish; Fred Newman; Paul Norton; John Oaker; Jim Poole; Howard Pryor; Mervyn Sanders; Tony Thorpe; and Norman Ward.

Many members attended without their cars and all enjoyed the hospitality Bletchley had to offer and the camaraderie of the Mayflower Club.

The awards this year went to the following: *Concours* — Howard Pryor.

Top Five — Pat McKeefry, John Gogay, Tony Thorpe, Jim Poole, Paul Norton. With the Top Five



Roger Turpin's Naffi Van

awards being so hotly contested only two of the five were in last years list. This competition is now firmly established and I think it is fantastic that there are so many cars in first class condition. Even cars that were winners a few years ago now have to concede to more recent restorations. I fear it won't be long before Mabel is toppled from the concours position.

Distance Award — Pat McKeefry from Northern Ireland.

Lady Drivers Award — Helen Hunter.

George Feary (most original) — Ken MacKenzie.

Forbes Alexander Award (non-concours) — Ben Miller. I would

like to remind members that this award is not a joke, it is a very serious attempt to encourage all cars, whatever their condition, to attend the rally. Changes are afoot to make this award more attractive to owners of original usable cars.

Chairman's Cup and Committee Award — Dave Miller.

Back Seat Memorabilia — Loretta Pryor.

Thanks

Thanks in abundance must go to the following: Bletchley Park Trust, nothing was too much trouble for them. All the poles, tables, chairs, and barbecues were theirs plus a host of other things. The Counter-part Rally sections in



John Oaker checking on membership dues!!

FLOWER POWER



The Mayflower Club's tent



*Ken MacKenzie
receiving his award*



*Helen Hunter receiving the Lady Driver's
Award from Peter Benfield and Tony Booth*

the other clubs for their part in organising the day.

Ron Cromar of the Roadster Club for organising a splendid dinner dance on the Saturday night. Roger and Margaret Turpin for serving tea and coffee all day from their Naffi van.

Sue Benfield for the most beautiful cake, suitably decorated with a Mayflower and logo which was served to all attending. To my wife, Loretta, and Joan Gogay for running the raffle/tombola.

To my assistants who turned up on Saturday afternoon and early Sunday morning to help set up and

to all those who helped during the day. I feel we are now a team — *a club*.

Many thanks to Reg Varney, a very long serving member (No. 3) who took the trouble to come and see us all. Reg explained to me that it was different in his day with the club in its infancy, it was very, very hard work to get a rally off the ground. Things don't change Reg! But I'm sure we both agree that it is all worthwhile.

I must save my most grateful thanks to those of you who turned up on the day. Driving those hundreds of miles to attend,

| Name | From | Member No. | Car No. | Miles to rally |
|---------------------|-------------------|------------|---------|----------------|
| Brian Barker | Nottingham | 810 | VFF 517 | 106 |
| Peter Benfield | Northallerton | 409 | KSF 804 | 286 |
| Phil Benson | Redhill | 490 | JBD 807 | 86 |
| Steve Coulman | Scunthorpe | 785 | XMG 7 | — |
| John Gogay | Dartford | 262 | PMV 97 | 109 |
| Helen Hunter | Isle of Wight | 708 | OOD 231 | 171 |
| Pat McKeefry | Randalstown, NI | 863 | ORB 639 | 289 |
| Ken Mackenzie | Newcastle-on-Tyne | 710 | FJR 391 | 285 |
| Ben Miller | Belper | 833 | DCN 190 | 113 |
| Dave Miller | Belper | 833 | XSJ 832 | 113 |
| Chris Naish | Wantage | 674 | CSN 107 | 59 |
| Fred Newman | Tenterden | 886 | NSJ 641 | 131 |
| Paul Norton | Bromsgrove | 462 | HTH 719 | 72 |
| John Oaker | Walsall | 715 | HBU 358 | 62 |
| Jim Poole | Daventry | 743 | LFG 805 | 43 |
| Howard Pryor | Barnet | 551 | NLO 739 | 45 |
| Mervyn Sanders | Newbury | 832 | ONN 153 | 77 |
| Tony Thorpe | Burton on Trent | 789 | NLM 888 | |
| Norman Ward | Derbyshire | 374 | 439 HYO | 118 |
| <i>Without Cars</i> | | | | |
| Tony Booth | Oxford | 544 | | |
| Roger Curtis | Street | 843 | | |
| Reg Varney | Bristol | 3 | | |
| Maurice Wilkes | Kings Bromley | 891 | | |

especially those we haven't seen before. New members and old enjoyed themselves so much that they can't wait until next year to come around so that we can do it all again!

Regrets of the day



The day never lasts long enough! All too soon its time to go home. I can't chat to everyone as long as I would like. Those of you who I didn't get around to I hope we can find the time next year.

I didn't get around Bletchley Park itself (in fact I didn't even get out of our quarter).

And finally for those of you who unfortunately missed this year's rally, or were unable to attend, I am sorry to tell you but you missed an absolutely fantastic weekend. To save further mind blowing disappointment I strongly suggest you attend next year otherwise you might become seriously depressed.

*See you there, happy Mayflowering,
Howard*

MINISTRY OF FOOD
25-06-00

**RATION BOOK
COUPON**

Surname.....Initials.....
Club.....

| | | |
|--------|---------------------------|--------------------------|
| TEA | TEA (milk no sugar) | TEA (milk & sugar) |
| COFFEE | COFFEE (milk no sugar) | COFFEE (milk & sugar) |

COUPON PROMISES THE BEARER ONE OF THE ABOVE BEVERAGES FREE OF CHARGE FROM THE NAAFI VAN.

COUPON VALID ONLY ON DAY OF ISSUE.

Next year

The ETCs are currently looking hard for a venue for next year's rally. If you know of anywhere suitable please let me know.

We are also looking to make a five-year plan so that everybody will know where the rallies are in plenty of time.

We are also exploring the possibilities of moving the rally around the country but for this we will definitely need feedback for ideas for venues.

It is up to you!!

Coupon used to get drinks from the Naffi van

Bletchley 2000 report

by *Peter Benfield*

OUR LAST two rallies at Kimbolton Castle in 1998 and at Burford Wildlife Park in 1999 had an excellent turnout of vehicles and proved to be such enjoyable occasions that it seemed a mammoth task to organise anything superior for this special year of 2000 — 25 years since the formation of the Club and 50 years of Mayflower motoring.

That our 2000 Rally did indeed surpass all expectations was in no small way a result of the fruits of

careful preliminary planning at our special meeting last November and the ensuing dedication of the committee members involved.

Our Rally Secretary in particular deserves special recognition for his efforts and his excellent liaison with the other Triumph clubs involved.

The Furzton Lakes Hotel in Milton Keynes proved an excellent choice for meeting up on Saturday afternoon providing ideal accommodation and atmosphere for greeting old friends.

Most people chose to be conveyed to the Dinner Dance in the evening by taxi. One could not help but feel a sense of history when passing through the doors



Convoy from the hotel to Bletchley Park

and entrance hall of this magnificent mansion.

Preliminary drinks in the bar from helpful staff preceded our entry into the beautiful wood-panelled dining room where individual clubs were seated together.

The relaxed atmosphere enabled all to enjoy a wonderful meal after which Alan Davies provided a most humorous and entertaining after dinner speech. He spoke slowly and deliberately on the theme of owning a Triumph car and how this experience takes one into a world of one's own, followed by a full and exceedingly funny

description of his hospital treatment after an accidental contact with his car's cooling fan.

Dancing in the adjacent ballroom helped to round off a really superb evening.

On the Sunday morning our Mayflowers were led in convoy by Steve Coulman making quite an impressive sight. Carefully negotiating the many roundabouts we eventually entered the grounds of Bletchley Hall where the rally marshals arranged us into two rows of nine fine Mayflower cars to set up the early morning display so efficiently organised by Howard Pryor.

GOOD HOME WANTED

Elderly club member has passed away and his son wishes the car to go to a good home so that the restoration can be completed

The car is located in Egham, Surrey

If you are interested please contact:

Jon Oates on 01491 614148

95% COMPLETE MAYFLOWER (1950)

Radiator is missing, but the engine runs. Stored many years
Needs a rebuild or great for spares

£120 if you collect it - needs trailer or fixed tow

Dave Jenkins

21 Avebury Road, Penhill, Swindon, Wiltshire SN2 5JR

Telephone 07788 408789

Rally disasters past and present — big style

by John Oaker

CAN ANY member tell me why this year HBU 358, with the new leather seats and a polish, picked up only one point in the Eurovision best six cars at the Bletchley Park rally.

Last year with nasty torn seats and no polish HBU 358 got eight points at the Cotswold Wild Life Centre.

The answer is simple — the standard of everything at our rally has improved. I'm not going through a list — those of you who were there know what I would have written — so thanks big style to Howard and your fellow rally secretaries.

Last year's rally was where my problems began. Why did I go up Birdlip Hill on a nostalgia trip knowing that the temperature gauge would show me grief.

I did, and it did, at the top of the hill the car stopped, the friendly AA man did some magic and off we went. No one else would see the little seepage of green liquid.

Rally came and rally went and on the way home — a puncture. I hadn't had a puncture for years.

I'm on gravel, the jack doesn't work, the spare is flat and the battery is dead in the mobile phone.

A brilliant, immaculate white Morris Minor pulls up behind and out steps an apprentice lone ranger who says can I help. He had everything. Polythene sheet to put on the ground, pump, piece of wood to put under his jack, water and soap to wash our hands, photo of his Mum and girlfriend, sense to follow us to the next garage.

At the next garage he carried on going, the William Tell Overture would have been playing but the radio wasn't working.

This year's rally, I pick the car up from the garage, Saturday morning at noon.

The green liquid problem from last year had needed sorting big style. Fortunately my telling the garage that I needed the car on the 1st May meant that it was ready by the middle of June.

Running-in all the way to Bletchley. It's always please pass

**YOU CAN
ADVERTISE IN
FLOWER POWER
FOR FREE**

*Just send your
advertisement to
The Editor*

anyway and I arrive in time to help put up the gazebo thing. Great day!

On the way home I stop to visit my mum and sister at Kilsby. I pull on to my sister's (new of the previous weekend) very nice bricked driveway.

Imagine my horror and my language when after a cup of tea I go to resume my journey and discover a big pool of oil on that brand new driveway right underneath my car. I couldn't even blame it on someone else's car. My sister said it didn't matter but *really* it did!

The fact that the car blew the back core plug just outside Coventry meant that I had to be relayed home on the back of a breakdown truck driven by an Oxford United supporter who knew every occasion when his team had stuffed Walsall — with

the score, who scored when and if anyone got sent off.

He was disappointed that England had got knocked out of Euro 2000 but he knew the reasons why this disaster had happened. I was afraid to tell him that I supported Middlesbrough!

PS — The Mayflower's back fixed, big style!

PPS — Hey mate why's that car blue when they only made them in black?

PPPS — Learnt to drive in one of them but it had four doors!

PPPPS — That's only survived cos they're all made of aluminium!

PPPPPS — Oh me husband and me did all our courting in one of them!

PPPPPPS — Can anyone out there add to the collection!



Some of the awards and the celebration cake in the club's gazebo

*Letters***Early bird**

What a ridiculous time of day to leave home for a National Rally, 5.00 am . . .

Sadly underestimating the density of traffic on the M25 motorway and the capacity of our Mayflower to maintain a steady 50 miles per hour we planned to arrive at the rally venue in time to enjoy a leisurely breakfast, we've never had such an early lunch!

This was our first national rally, terrific venue, well worth the effort, having only recently joined the club and residing in deepest rural Kent, one has limited opportunity to compare vehicles and meet other owners.

Check list

However I am pleased to have been advised that our vehicle (owned for one year) had been fitted with incorrect side lamps, the interior trim was not quite correct, the car is not quite the correct shade of grey and she has a few other minor discrepancies which hopefully will be addressed by the next national, we are getting there . . .

More to the point, and illustrating what the national rally is all about, upon parking it was pointed out that the exhaust was emitting some black smoke, indicating a blocked pilot jet, which a member of our committee

promptly removed and rectified (thanks Steve).

However on restarting the vehicle to check the idling speed it was discovered that the carb had shaken loose and fuel was spilling alarmingly, this being the cause of erratic performance for the last few miles to the rally, and potentially a situation of some danger.

As my tool kit was not overly comprehensive, it became redundant when our Chairman produced the necessary equipment to resolve the problem (thanks Peter).

A great day out, some great cars, almost all types of early Triumphs, some very friendly people and to top it all I won a bottle of Scotch whisky in the raffle!

*Fred & Phyllis Newman
(Member 886 in NSJ 641
(Not quite Cotman Grey)*

**Australian
Mayflowers**

Ann and I are just back from a holiday in Australia where we started in Sydney having travelled via Singapore, went up to the Great Barrier Reef, across to Ayers Rock and then back to Sydney. Quite a trip!

Whilst there I took the opportunity to visit a couple of TRC members and one of them, Arthur Moorhouse, who lives in North Nowra, about two hours drive south of Sydney, had in

addition to his Roadster (and also a Renown) the Mayflower utility shown in the enclosed photographs.

Arthur states that this is a genuine factory-built or assembled vehicle. He has rebuilt the engine and is almost done with the bodywork, but then found that the head gasket had leaked and the engine now needs a further rebuild due to coolant ingress, but he is working on it.

When we arrived at Arthur's house, we found that he had invited his friend, Bob Mann, who has a very nice red Mayflower that he has had for six years, during which time he has fully restored it.

Arthur says that Bob has driven it on a couple of long rallies of 1,000 miles or more. It goes well and is a very tidy vehicle with an excellent paint job.

*Ron Cromar
(Triumph Roadster Club)*

The 100 mile per hour Mayflower

In the summer issue of *Flower Power*, No. 96, page 17, you posed the question re 100 mph Mayflowers.

Here are the pictures that answer that question.

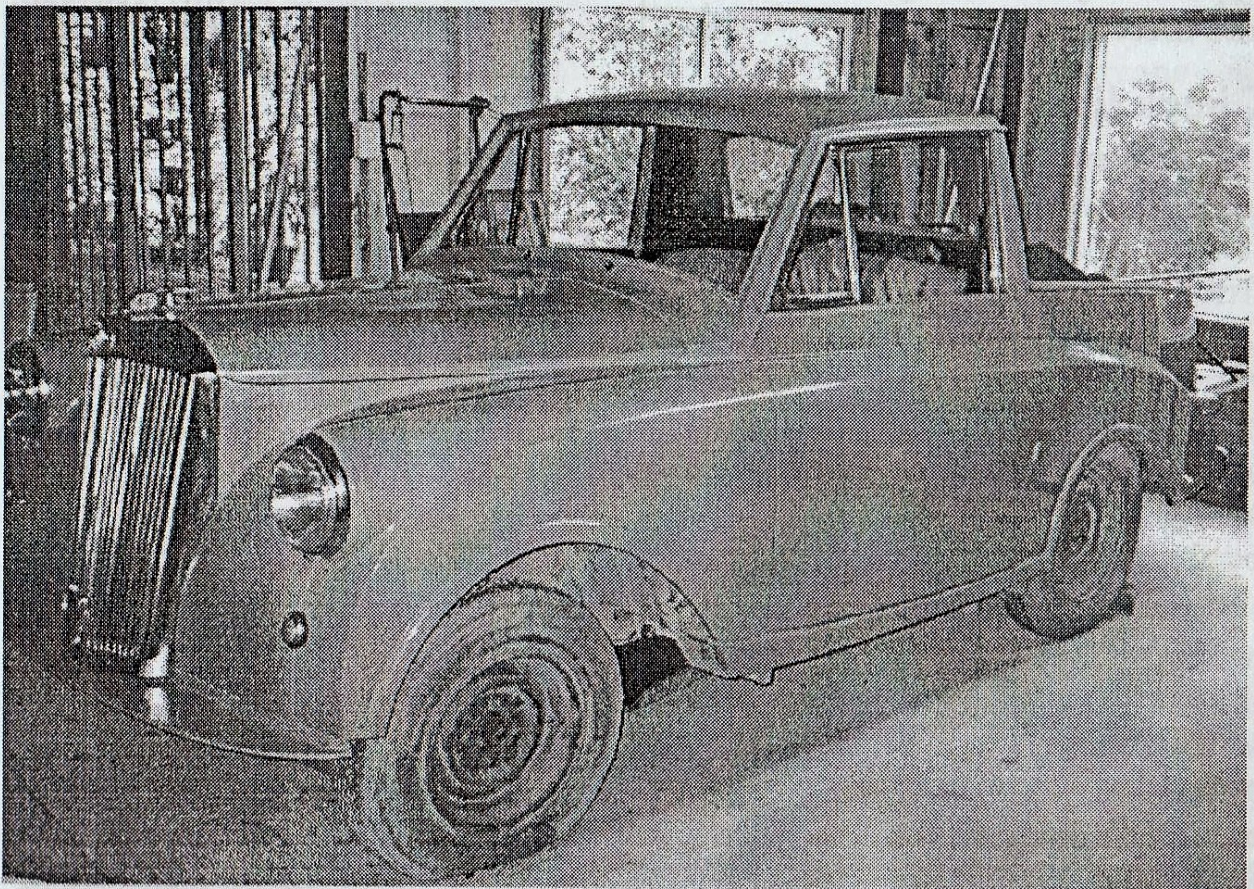

Australian Utility

FLOWER POWER

The body was found on an old dried up road less than a mile from my home. It had been left to die for 35 years, had no glass left in it and everything from the waistline down was well rusted and completely gone.

Needless to say that countless hours of MIG welding and fabricating work was required to bring it back to life again.

Features include 2 inch by 3 inch mild steel frame, 10 point roll cage, narrowed (by 2 feet!), Lincoln rear end, Ford Mustang II front end, narrowed by 6 inches — disc brakes all round, Ford 460 cubic inch engine, C6 3-speed automatic transmission, hand

made aluminium radiator, 12 gallon fuel cell and all hoses are braided stainless steel.

The rear window is the only original glass left in the car. The entire front end comes off in less than a minute thanks to the use of ¼ turn DZUS fasteners. The car is street legal and now has more than 3,500 miles recorded on it since the rebuild.

Thanks to my brother Dave for all his help! We love our Mayflower. Thanks too for all the help we got from the club.

*Bye for now, Peter (and David)
Shoemaker, Member 874
Huntsville, Ontario, Canada*

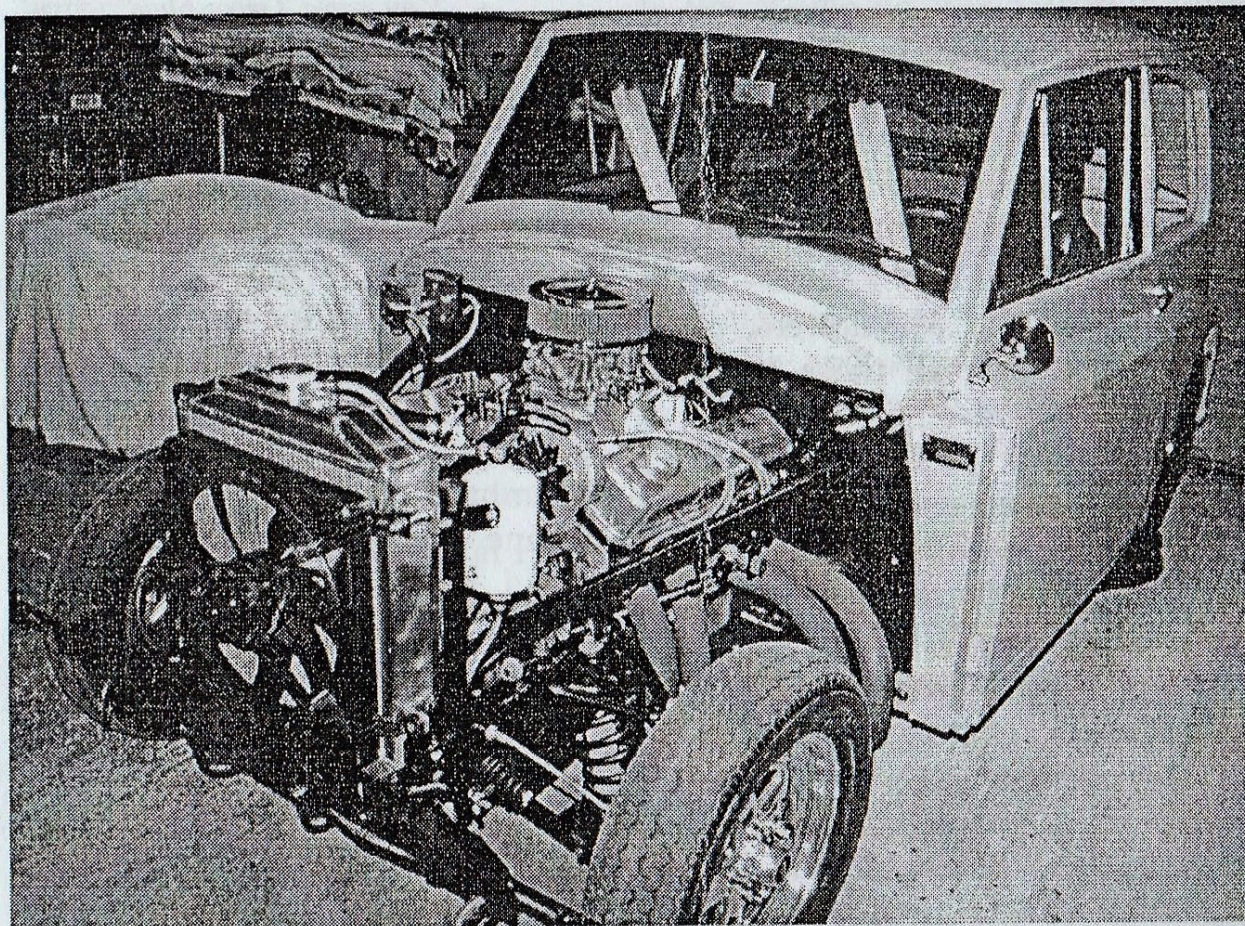

What a flyer!!

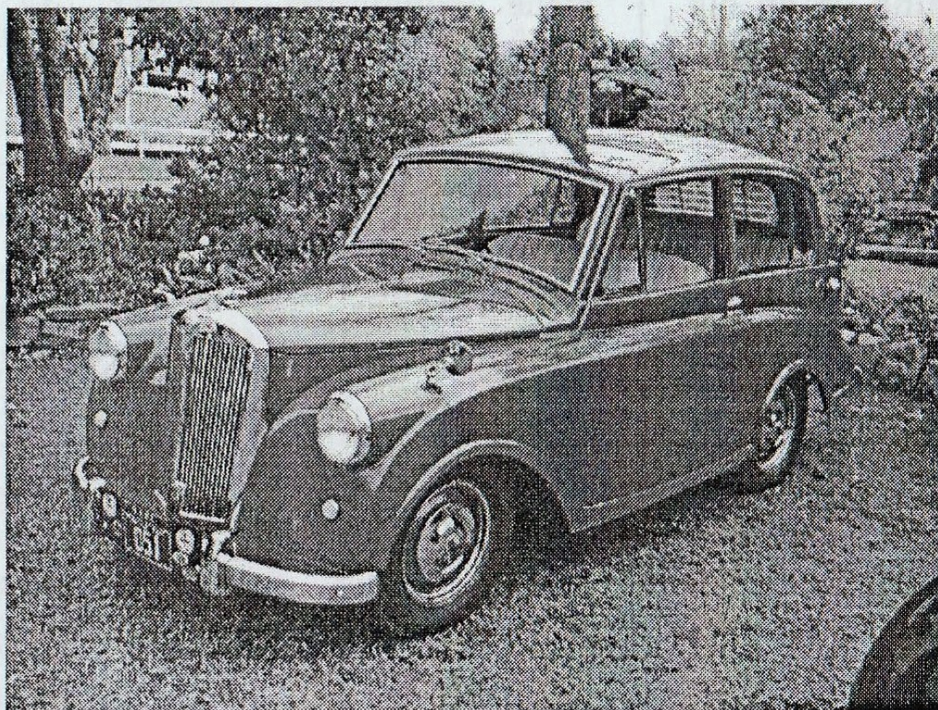

*Another
Australian setting
— Bob Mann's
very nice looking
Mayflower*

Thank you

Dear Howard,

Just a quick note to say thank you for organising such a successful and entertaining rally at such an unusual venue. You and the committee obviously put a lot of hard work into it.

As well as the Mayflowers, of course, there were all those super Renowns, Roadsters, Vitesses, Dolomites and others to drool over. I even managed to find time to explore the park itself and tack myself on to one of the guided tours for a while.

It was very nice to have the opportunity to chat to members of the committee and other Mayflower owners again. I especially enjoyed my lengthy and fascinating conversation with Mrs Jeary and her son, Mike. Both you and the committee did them proud

and they were tickled pink to have been invited as guests of honour.

*You have Triumphed again!
Chris Naish (647)*

Triumph Forum

Dear Howard (Pryor),

I was grateful for the chance to join you at the Triumph Forum earlier this year. One of the actions emerging from the meeting was for brmmbrmm.com to develop an on-line discussion forum. This would span all of our Triumph clubs and collect views and experiences of unleaded fuel.

It has taken me a little longer than planned but I am delighted to announce that this is now live and available.

There are no access controls so you and all of your club members are now able to visit, view and

contribute to it. So please stop by at www.brmmbrmm.com and give your two pennyworth.

The themes being discussed now include: unleaded heads; additives; wear and tear and performance; octane boosters.

I would welcome your feedback on this facility and be more than happy to make changes. I want to make sure people find it easy to use and helpful. You can e-mail me with views or use the feedback form on the web site to send comments.

Best regards, Phil Hulme

E-mail: admin@brmmbrmm.com

Tel: 07785 901976

An event not to be missed!

This year my wife and I were celebrating our Silver Wedding and we had the Mayflower Club Annual Rally on the same date.

What could we do? Miss the jubilee celebrations at home or the jubilee celebrations in Bletchley. We decided to attend both.

We took the Super Sea-Cat from Belfast on Friday and arrived in Heysham that night.

We travelled to Birkenhead and spent the night with my sister, husband and family. The next day we started early and arrived in Bletchley in the early afternoon.

I met Howard at the park, there he was, with his car covered in case

anyone could see it. He said it was to keep the rain off but nobody believed him!

Soon many others arrived and I had the pleasure of meeting John Gogay and his lovely wife Joan, along with Steve Coulman and many others whom I did not recognise as readily (they haven't appeared as often in *Flower Power*).

When all was ready for the big day we went back to the hotel to meet our wives and have some refreshments. Time passed quickly and we were soon meeting for the dinner.

It's amazing how someone seems to forget something for these weekends. We forgot the food for the barbacue, one guy forgot his jacket and tie and I was told another member forgot his wife but may be she wanted to go somewhere else.

We had a lovely dinner in the stately oak-panelled banquet hall at Bletchley Park. Good food, good music and as we say in Ireland, good crack (without the drugs). An enjoyable night was had by all.

Next morning I was spotted out early washing and polishing. After such a long journey in the rain a lot of dirt had gathered and I don't have a cover, yet!

We set off in convoy behind Steve Coulman who took us through Bletchley from north to south, from east to west and then through the middle again. Lucky the show wasn't in London!

FLOWER POWER

All the local people seemed to notice the cars but when they didn't we gave the horns a blast or two. That woke them up! Anyhow well done Steve, you didn't get lost in spite of what some people thought.

When we arrived Howard directed us into position, I parked beside the youngest Mayflower belonging to Helen Hunter who had travelled from another offshore island in the south.

got to it! I knew it would be needed in the not too distant future.

Before long John Oaker gave me a judging form. That was the hardest bit of the weekend. I had to list the cars in order. It felt as if I was trespassing when I went to look at cars especially if the owners were in them.

After sorting out the first two it became easier and I was quite enjoying it at the end. When other members came to inspect my car



The Mayflower table at the Saturday night dinner

In all 19 Flowers arrived, one short of my prediction. I could have been spot-on but one owner had a mishap and had to bring his other car.

The sun shone and we had plenty of time to look at the autojumble and I managed to pick up a gasket set before John Gogay

they were quick to notice the differences between the early Mayflowers and the more recent ones. I handed in my form and we went off to have a look around the museum and have a cup of tea.

Before long it was barbecue time and we still had no food until some kind members offered to share

what they had (sorry chaps if you went home hungry but your food was lovely and you have very kind wives!).

The day passed quickly and soon it was awards time. Howard won the concourse for the eighth time, we had made the top five and won the distance award by five miles!

We would certainly have won it on the homeward journey as we were delayed by roadworks, missed the boat and had to drive to Carnryan in Scotland to get home in time for our other jubilee celebrations. Did you know a Mayflower with a bad engine could do 65+ mph when it has to?

On the way back to Birkenhead (before the diversion) I was taking it easy when our flying chairman, Peter Benfield and his wife, shot past and quickly disappeared into

the distance. Look out Peter, for next year I am having a V8 3.5 Litre fitted!

This was my first visit to a club event and I thoroughly enjoyed every minute of it. It was a pity more members couldn't attend this special millennium occasion but perhaps next time there will be 20+ cars.

It would be lovely to see all running Mayflowers together on one occasion. Could it be next year?

Thanks to all the organisers, especially Howard and Loretta Pryor who must have brought half the contents of their house to make sure all essentials were available.

*Pat McKeefry, No. 863
Northern Ireland*



*Pat McKeefry (Distance
& Top Five)*



*Reg Varney (Special
Certificate)*



*Ben Miller (Forbes
Alexander)*

Rambling around

by Dave Stafford

AS I SIT waiting for someone outside of an office near Paddington Station, watching life go by I muse on tomorrow. Saturday 10th June is my big day — the Mayflower's MoT test.

It should have been done weeks ago but I was too busy organising a Fiesta with dancing girls, singers, musical clowns, fire eater — the list goes on and on.

The Classic Car Shows are almost upon us — we went to Penshurst Place but it was rained off. We went to Enfield and it poured again so it was rained off. I wonder how many more will have been rained off this year. It has been very wet, and shows no improvement to date.

I have high expectations of the Mayflower getting through the test this year. I intend to go to a small show in the afternoon if she passes okay.

The show is at Elmfield and is run by our Triumph Roadster regional cousins. I like to go to the show and to get invited to their dinners and road runs, which are usually very nice and friendly. I will have to turn the Mayflower into a drop-head convertible one day just so that I am not the only saloon car present.

Web site

Have you visited our web site recently? I did when it first came out but need to visit it again to see how it is coming along. You can imagine how surprised I was when I found my own car and even a photo of me on the www — fame at last. Yes I know I was disguised but what the heck!

DO YOU LIKE THE COLOUR COVER?

For this special year the cover for this issue of *Flower Power* has been printed with colour photos at a cost of approximately £90 extra. The committee would like to know from members if you would like one issue per year to have a colour cover.

**Please reply with your views to
Phil Benson**

I am open to invitations to weddings, funerals, films, TV work, Carnivals and Car Shows.

Life is not over for the old girl yet. One day I must write a book on my adventures with my classic cars.

Which one

I have just had a new engine put into my Triumph "TD" so I will hopefully turn up to one of our combined shows in it. It has never been to one yet.

That's the trouble with having two cars — which one do you use. Any suggestions on TinaDavid@bun.com — we have been on the internet for a year now and it was without doubt the best thing we have ever done.

We are now in touch with friends and family all over the world, from Caterham to Canada, USA, Philippines and expanding every day.

There are lots of sites that you can visit to buy or to sell classic vehicles, or you can just look.

I have lots to thank the Mayflower Club for. Peter Benfield, the Chairman helped me to buy my car three years ago. Honestly Peter, the photo on the web-site is me.

The car had 38,000 on the clock when I got it and so far has clocked up another 3,000. I believe that's the lot and that the mileage shown is genuine.

For the past year I have been running on a catalyst using unleaded petrol. Everyone tells me the catalysts are crap but I have had no trouble at all so far. Is anyone else on a catalyst? If so have you had trouble with it — please let me know. Hopefully I will recoup the £50 I paid fairly quickly.

Fingers crossed for the MoT.

Dave Stafford, Member 822



Some of the 19 Mayflowers assembled for this year's National Rally at Bletchley Park, Milton Keynes

What a night out

by *Phil Benson*

I HAD A really great evening out at the Plough Inn at Bletchingly in Surrey recently. John Hardy of the Triumph Roadster Club's Kent and Surrey Border's group invited me to a joint gathering they were having with the Surrey Vintage Vehicle Society.

As it was a pleasant and sunny evening I decided to go along and having dusted down my Mayflower set off not knowing what to expect.

On arrival I found that a field behind the pub car park was already half full of some very interesting and exotic cars. Of course there were plenty of Roadsters and my Mayflower was not the only one there as John had also invited Dave Stafford who lives in our area too.

What surprised me was how many cars the SVVC turned out.

They must have had over 50 members with an amazing variety of cars there.

From memory I can recall seeing several cars that predated the First World War (1914) and more than half of those there that were pre-1950. There was a truly amazing collection of vehicles present and it would be unfair to name any in particular.

Stupidly I forgot to take my camera with me, but will make sure it is with me in future. I discovered that the SVVC is the largest independent club in the UK. Since they only charge £13 per annum for family membership I have decided to join in order to get to know a few more like-minded people locally and to be able to join them on their summer lunches and pub evenings etc.

I hope to attend some of their winter evening meetings where members share information and often have speakers on motoring topics etc.

1952 Triumph Mayflower For Sale

Grey with no log book

Ideal for spares or restoration if you have lots of time

Rough but complete

Contact:

Barrie Freeman, Middle Farm, Middletown Lane, Upleadon, Glos GL18 1EQ

Tel: 01531 820350

Federation of British Historic Vehicle Clubs

ONCE AGAIN the Triumph Mayflower Club have renewed their affiliation to the FBHVC.

The subscription is on a per capita basis and at 27p per member the costs to the club run out at less than £50 per year. The Club has always thought fit to be a part of this organisation which with Lord Montague of Beaulieu as president

lobbies so effectively for the classic car movement.

The most recent campaign was against a European 'End-of-Life' directive which now has two amendments that effectively exclude historic vehicles from its scope and allow for their de-registration.

Effective lobbying at UK and European levels once again proved to be successful.

The AGM of the FBHVC will be held in Northampton on Saturday 14th October 2000 at 11.00 am at which revisions to the current constitution will be debated. As these do not seem to materially affect this club we do not propose to send a delegate this year.

REASONABLE OFFER PLEASE

My father wrote to the Club in 1994 regarding his Mayflower

1952 RPF 837 TT17845DL

However, unfortunately he and my mother have now passed away and I have inherited a car that I have no means of restoring

I have the original service manual, bills etc
and would like the car to go to someone who will give it
a loving home

Is there anyone there who will make me
a reasonable offer for the car

Contact:

Robin Clifton, 84, Gardner Road, Southwick
West Sussex BN41 1PL

Some garages selling Leaded 4 Star

with acknowledgements to the FBHVC Newsletter

| | | |
|----------------|---|---------------|
| Avon | Markham Filling Station, Martcombe Road, Easton in Gordano, Bristol | 01275 372122 |
| Bedfordshire | Chalk Hill Service Station, Watling St, Chalk Hill, North Dunstable | 01582 475588 |
| | Sawfords Garage Ltd, Church St, Tempsford, Sandy SG19 2AN | 01767 640238 |
| Berkshire | Gleneagles Garage, Victoria Rd, Wargrave, Reading RG10 8AH | 0118-940 2961 |
| Bucks | Pinewood Services Ltd, Iver SL0 0NL | 01753 653600 |
| Cheshire | Park Filling Station, Lymm Rd, Lymm WA13 0UA | 01925 757106 |
| Clwyd | Dobshell Garage, Chester Rd, Dobshell, Hawarden CH5 3LZ | 01244 545115 |
| Cumbria | Grizebeck Service Station, Grizebeck, Kirby-in-Furness LA17 7XH | 01229 889909 |
| Derbyshire | The Garage at Smalley, 75 Main Rd, Smalley, Ilkeston DE7 6DS | 01332 880279 |
| | Cottage Filling Station, Swarkestone Rd, Cuttle Bridge, Swarkestone | 01332 700304 |
| | Ladywood Service Station, Baslow Rd, Holymoorside, Chesterfield | 01246 569864 |
| Devon | Stopgate Service Station, Junc A303/B3170, Yacombe | |
| East Sussex | Classic Dream Machine, Little London Rd, Horam, Heathfield | 01435 812539 |
| Essex | South Hills Garage, South Hill, Langdon Hills, Basildon SS16 6JD | 01268 322376 |
| Hampshire | The Garage, Farleigh Rd, Cliddesden, Basingstoke RG25 2JL | 01256 322376 |
| Hertfordshire | Biggerstaffs Garage, Green End, Sarratt WD3 6AR | 01923 262591 |
| Kent | P. D. Andrews, rear of Tollgate Service Station, Gravesend | 01474 564481 |
| | Flight Service Station, Main Rd, Biggin Hill, Westerham TN16 3BA | 01959 270310 |
| Lancashire | Forton Motors, Lancaster New Rd, Cabus, Garstang PR3 1AB | 01524 791778 |
| | Junction Garage, Liverpool Rd, Longton, Preston PR4 5QD | 01772 616152 |
| Leicestershire | Broughton Astley Motor Spares, Main St, Broughton Astley, Leicester | 01455 284220 |
| Lincolnshire | Pointon Garage, High St, Pointon, Sleaford NG34 0LX | 01529 240471 |
| Middlesex | Baberbridge, 13 Staines Rd, North Feltham, Feltham TW14 0HW | 020-8890 6256 |
| Norfolk | Wortham Garage, Bury Rd, Wortham, Diss IP22 1PX | 01379 898437 |
| Northants | Acre Lane Garage, Acre Lane, Spring Park, Northampton NN2 8BN | 01604 843413 |
| | Townends Garages Ltd, 58 High St South, Rushden NN10 0QY | 01933 359111 |
| Oxfordshire | Tiddington Garage, Oxford Rd, Tiddington, Thame OX9 2LH | 01844 339210 |
| Somerset | Shepton Mallet Motors, Townsend Rd, Shepton Mallet BA4 5SB | 01749 344422 |
| | Upton Noble Garage, Gullys Lane, Upton Noble, Shepton Mallet | 01749 850226 |
| S. Yorkshire | White Lane Service Station, 179 White Lane, Gleadless, Sheffield | 0114-239 8769 |
| Staffordshire | Crown Garage, Cheadle Rd, Leekbrook, Leek ST13 7DR | 01538 382600 |
| | Mount Garage, Leek Rd, Werrington, Stoke-on-Trent ST9 0DQ | 01782 550241 |
| Surrey | Arnolds Garage, Shottermill Pond, Camelsdale, Haslemere GU27 3RB | 01428 643192 |
| Warwickshire | Station Garage, Warwick Rd, Kineton, Warwick CV35 0HT | 01926 640233 |
| West Midlands | Norton Canes Service Station, 154 Lime Lane, Pelsall, Walsall WS5 3AS | 01543 373444 |
| | Gospel Oak Service Station, Gospel Oak Rd, Tipton DY4 0PS | 0121-556 1372 |
| West Sussex | Golding Barn Service Station, Henfield Rd, Small Dole, Henfield | 01903 814444 |
| W. Yorkshire | Moor Motor Services, King Lane, Alwoodley, Leeds LS17 7AW | 0113-267 3733 |
| | Thrust Granada Service Station, Junc A1/A63, South Milford, Leeds | 01977 682711 |
| Wiltshire | Circuit Motors, Chippenham Rd, Castle Coombe, Chippenham | 01249 782596 |
| | St Margarets Garage, Highworth Rd, Stratton St Margaret, Swindon | 01793 823166 |
| Worcs | Bridge Garage, Abbey Rd, Evesham WR11 4ST | 01386 765171 |
| | Ryecross Garage, A438, Birtsmorton, Malvern WR13 6AF | 01531 650241 |

Ruby gets a lift to Mallory

by Pat McKeefry

OUR LOCAL Triumph Club of Northern Ireland decided to accept an invitation to have a stand at the Triumph International Millennium Event (TIME) at Mallory Park on May 28-29.

I was told that I could take part in the parade lap since I had, at that time, the oldest Mayflower on the road in the UK. (I believe there is another one about to claim this title, so best wishes to the rebuilder. I look forward to seeing one the same as mine.)

I decided to go since I had a couple of days off work for the May Bank Holiday.

We set sail from Belfast on Saturday night and after a good meal we had a chat and retired to bed. The crossing was uneventful and by early morning we awoke to a beautiful breakfast on board.

We arrived in Liverpool before most people were up. One of our group had broken his TR6's exhaust on the ramp when boarding so we had to repair that before we set off down the M6.

Before long the Triumph Renown started to complain. It transpired that it had broken a speedometer cable and was making a strange clicking noise. So on we went.

Shortly after we joined the M6 it was the turn of the Mayflower. It didn't want to be outdone by the younger cubs! There were a few splutters and then all went quiet. An eerie experience, especially when you are one of seven cars and 13 people.

I had to give in to being towed by one of our party in a V8 3500cc TR7. Then the police arrived and politely suggested we should move to a safer place to find the fault.

At a local service station we tested all electrical parts and eventually discovered that the rotor arm had shorted out.

I had already called the breakdown service and unfortunately when they arrived they did not have a replacement. Neither did I so the only solution was to be 'rescued'.

Drowning

I felt as if I was drowning! The weather made that almost possible. We were 'rescued' to Mallory Park in less time than I could have driven and no petrol costs. Thank you Footman James and the Mayflower Club for recommending them.

At Mallory I did a quick search and found a new rotor arm. It was soon fitted and Ruby roared, well spluttered, to life again. All was not perfect but the engine was running.

The first day was nearly over and I had spent most of it fixing or watching others fix my car.

We went for dinner a short distance away — it turned out to be 12 miles — but we got there with only a tail light bulb giving up. On the way back Ruby kept going but I could sense all was not well.

I knew all would be well on Sunday because Howard Pryor was coming with a bag of spares. *I must acknowledge the tremendous help and support he has been to me since I joined the club.*

I was in line for the parade lap when he arrived and he had a quick look over my car and then he looked less anxious.

Under threat

A friend of ours had told him about this lovely Mayflower and he was worried. His concourse position was not under threat after all! I invited him to join me on the parade and he willingly obliged.

Now that was an experience not to be missed. I felt like David Coultard on the front row of the grid and leading into the first corner as well. Did you see the photos? All those tyre marks were from our test laps!!

We led the Triumphs and Standards around for three laps during which time Ruby had a

NOTICE

*Closing date for articles for the next edition is
December 4th*

to Steve Coulman please

cough or two and even resorted to having a bit of a smoke as we came out of the chichane for the second time — no not from the tryres!

Then I knew all was not well with the engine. We managed to complete the parade and returned to the 'pits' for more checks and a tweak or two.

Mechanics

During the search for the fault at the service station one or other of the six 'mechanics' had adjusted everything he could find. The engine was getting too much petrol, was advanced too much, too little, tyres were too hard, too soft, well whatever, all I know was it wasn't going well. As you can see I know little about mechanics but I am learning fast.

I had a quick look around the autojumble and bought everything that looked like a Mayflower part.

We had to leave early in order to catch the night sailing from Liverpool. Ruby went well as long as I didn't go above 50 mph. We made such good progress that we had time to stop for a meal on the way.

It was an enjoyable weekend but it could have been better had I been able to watch the racing instead of having my head under the bonnet for a lot of the TIME.

An experience not to be missed but it is not a good idea to bring a car out of the body shop on the same day as you are going on a long trip. Now that won't happen again!

Classic Car Sills

Parts for the Triumph Mayflower

Key
Teleph



Part No: SILL £20.00

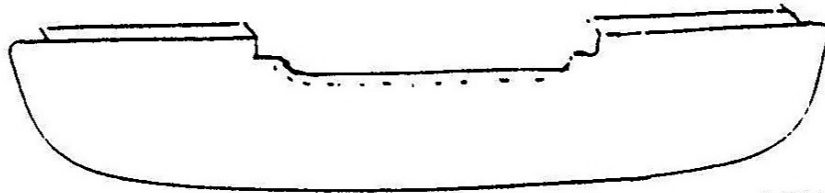

Part No: FRONT APRON £45.00

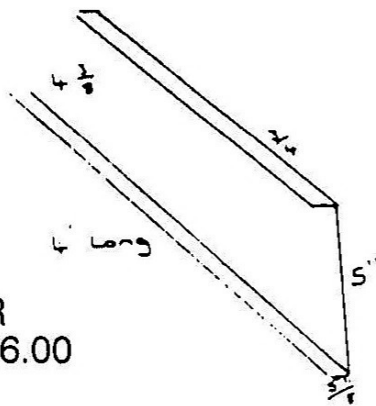

INNER SILL £6.00

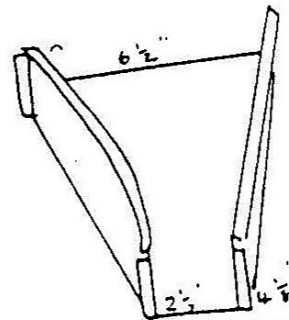

OUTRIGGER £7.50

Inner Sill £6.00

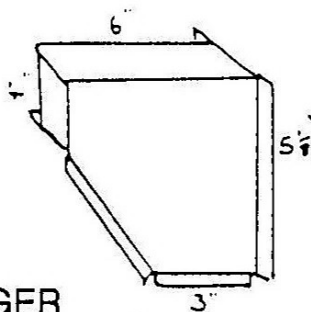

OUTRIGGER £7.50 ~~£7.50~~

REAR SPRING CHASSIS £7.50

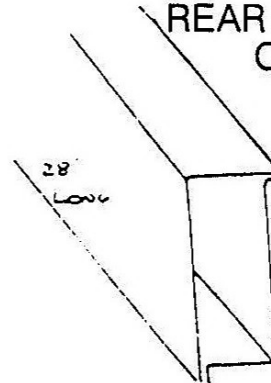

J. COLLIER

4 Mortimer Road, Kempston, Bedford MK42 8RE
Tel: 01234 840958 (Evenings) or 01480 477530 (Works)

