

Triumph Mayflower Club

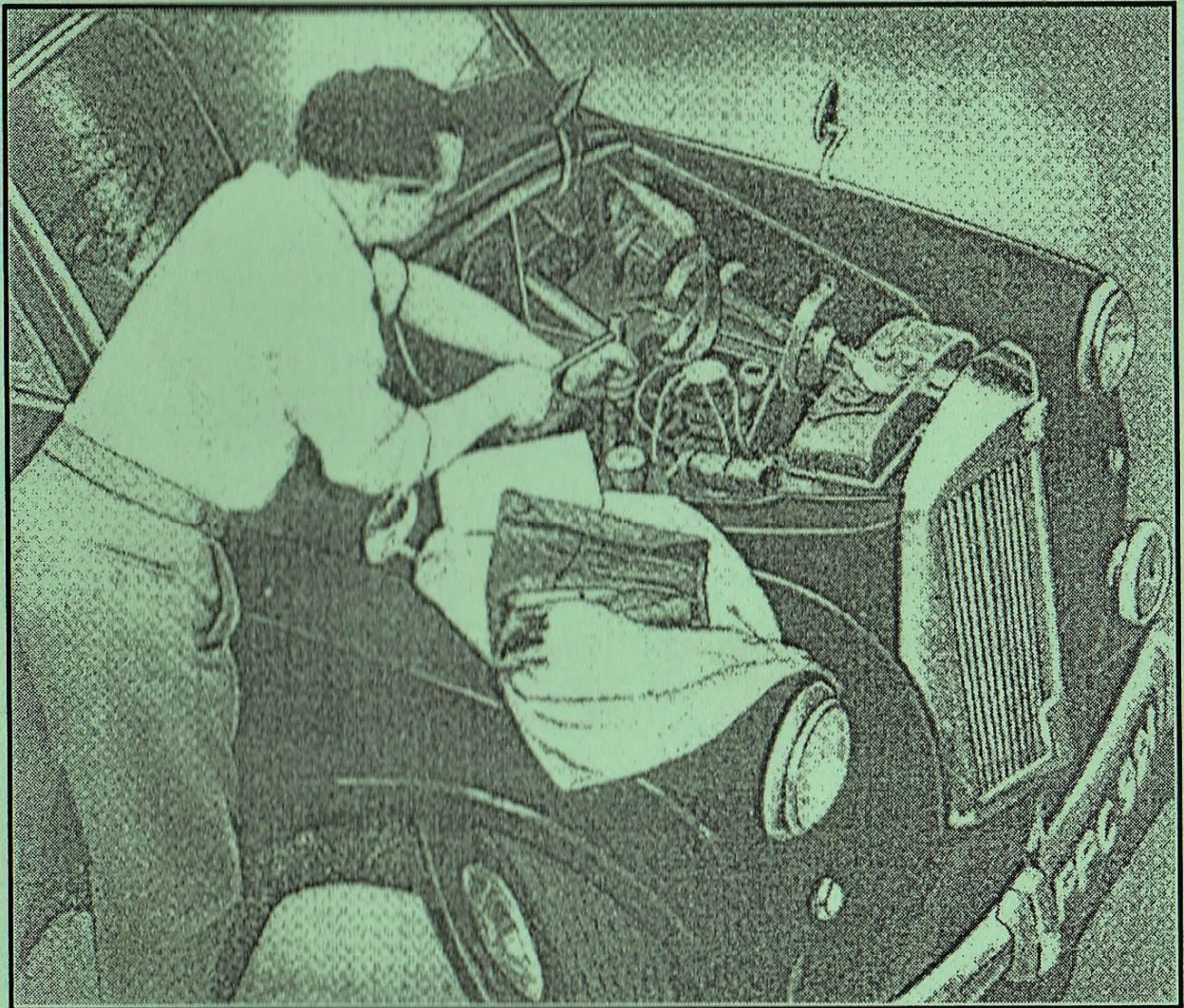

Worldwide Membership

SPRING ISSUE 2000 No. 95



FLOWER POWER

THE TRIUMPH MAYFLOWER CLUB

Club Officials for 1999-2000

CHAIRMAN	Peter Benfield, Amberley, Crintle Carr Lane, Thornton-le-Moor, Northallerton, N. Yorks DL7 9DZ
VICE CHAIRMAN	Tony Booth 1 Parkside, Hensington Gate Woodstock, OX20 1UR Tel: (01993) 811642
GENERAL AND MEMBERSHIP SECRETARY	John Oaker 19 Broadway North Walsall, West Midlands WS1 2QG Tel: (01922) 633042 E-mail: johnoaker@btinternet.com
NEW SPARES SECRETARY	John Gogay Cherry Hinton, Orchard Way Wilmington, Kent DA2 7ER Tel/Fax: (01322) 221493
MAGAZINE EDITOR/ TREASURER	Phil Benson 4 Dunlin Close, Redhill, Surrey RH1 5HJ Tel: (01737) 772202
RALLY SECRETARY	Howard Pryor 12 Park Road, High Barnet, Herts EN5 5SQ Tel: 020-8440 8623
CLUB HISTORIAN/SECONDHAND SPARES CO-ORDINATOR/ JOINT EDITOR	Steve Coulman 23 Park Street, Messingham Scunthorpe, S. Humberside DN17 3RU Tel: (01724) 762061 E-mail: stephencoulman@globalnet.co.uk
ORDINARY MEMBER No. 1	Tony Thorpe
No. 2	Forbes Alexander
No. 3	David Miller
No. 4	Paul Norton

*When writing to a committee member and you require a reply, please enclose a
Stamped Addressed Envelope*

*Please note that all the above committee members fulfil their positions in their spare time and not
as a full-time occupation, so when contacting them other than by letter, please ensure that
you choose a reasonable time of day*

CONTENTS

EDITORIAL	Page 2
CHAIRMAN'S REPORT	Pages 3 - 4
DID YOU KNOW	Page 6
GREENWOOD'S EXHIBITIONS	Page 7
LETTERS	Pages 8 - 10
RALLY NEWS	Pages 15 - 17
INTERNET	Pages 18 - 19

The information contained within Flower Power is the view of the writers and not necessarily those of the editor or the Mayflower Owners Club. Every effort is made to ensure the accuracy of the information contained, however use of such information is entirely at the members own risk and neither the club nor any individual shall in any way be liable for injury, loss or damage resulting directly from the use of such information.

NOTICE OF

ANNUAL GENERAL MEETING SUNDAY 26th MARCH 2000

2.00 to 4.30 pm to be held at

**ALUMWELL JUNIOR SCHOOL
PRIMLEY AVENUE, WALSALL WS2 9UP**

(The school is situated 400 yards from the M6 Motorway
Junction 10 roundabout — in the direction of Walsall)

AGENDA

1. Apologies for absence
2. Minutes of the last AGM and matters arising
3. Reports from committee members
 - Chairman
 - Membership Secretary
 - Treasurer
 - Spares Secretary
 - Editor
4. Election of Officers
5. Spares Secretaries Reports
6. Any other business

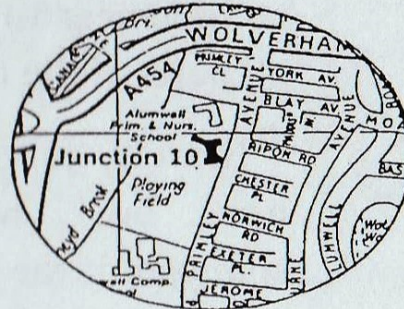

Notes:

Correspondence about the AGM — Any apologies for absence, informal enquiries about committee posts, nominations for committee posts etc should be sent to the Chairman
 Election of Officers — the posts of Chairman, Vice-Chairman, Treasurer, Secretary and Ordinary Members all come up for re-election at the AGM. The present holders are allowed to be re-elected, unless they no longer wish to stand.
 The jobs of Spares Secretaries, Magazine Editor, and Archivist are appointed by the committee so do not become available automatically at the AGM.
 Any Other Business. This is an open forum session. The Chairman tries to get the rest of the meeting completed in the first hour which gives plenty of time for a more 'informal' approach to be taken and for everyone to join in. Please do not think it is a 'boring' afternoon. Everyone there is just as interested in Triumph Mayflowers, and probably all cars, as you are. Please try to attend if you want to take a more active part in the club. It is a great chance to make friends, and possibly arrange next summer's outings to rallies, etc. If you come, try to bring details of your local events.

EDITORIAL

A sad loss

IF YOU ever had to contact our membership secretary, John Oaker, by phone you often spoke first of all to Mary. Always pleasant, always polite, always charming, more often than not witty and never failing to pass on a message. Sadly she is no longer with us. She died shortly before Christmas having suffered from a severe form of cancer for a few months. She had faced this challenge bravely but was not fortunate enough to be able to overcome it. We send the deepest condolences to John for this sad loss from all parts of the club.

Bravely, John says that it's business as usual, but I would ask members not to complain if the service is a little less prompt than usual for a while

Chairman's spring report

AS THE UK the long winter evenings are now receding and we are having some of those days that start off with crisp and frosty early mornings, turning into bright sunny weather with clear blue skies our thoughts are turning to the warmer days ahead when we can all put our classic cars into more regular use without fear of the adverse effects of the dreaded winter salt and grit.

My first thoughts for the spring magazine however centre upon the sad loss our secretary, John Oaker, experienced in late December. All the committee members were deeply distressed to learn of the passing away of Mary who had long been a tower of strength to John. We had all enjoyed her company at our rally gatherings etc and especially at the Saturday evening social dinners held prior to the rallies that we have been holding for the last three years. John will miss her dearly, and I am sure I speak for all members of the club in extending our deepest sympathy to John at this sad time.

Our special planning meeting in late November proved very useful with ideas for the June Four Club Rally discussed and a tentative programme arranged. With so much preliminary work debated

I'm sure our AGM in March will be made much easier when no doubt the programme will be discussed again and hopefully finalised.

All members are invited to this quite informal gathering. New faces bring new ideas, so make your effort to be there. If you cannot attend, but have an idea, please share it, just give a committee member a ring and talk it over with them. They will raise it at the AGM for you.

Fuel

My final thoughts are concerned with the still on-going leaded fuel debate. Have we all been worrying unnecessarily?

Having checked through all the additives recommended etc it now appears that there may still be a supply of leaded petrol — albeit at a quite extortionate price — at various garages spread throughout the UK.

The European Union directive does allow a very small proportion of unleaded fuel to be supplied. This will become available in all English counties and probably in the population centres of the other UK countries.

Bayford Thrust possesses the only licence to supply leaded fuel and a list of garages was published recently in the motoring column of the *Daily Telegraph* recently.

Further garages are expected to be added to this list, as tanks become available, so all is not yet

lost for our old side valve engines. Perhaps with a little care when planning our routes our future seems much more assured than we dare have hoped a few months ago.

I have just purchased a copy of *Triumph World* and was delighted to see the 'Quick Box' article on Dave Miller's engine and gearbox conversion (a 'Herald' implant).

All publicity for our model is welcome publicity, usually followed by increased enquiries to the club. I'm sure this article will set many members thinking. It is informative, well written, and with some excellent photos of Dave's car. Any maroon mayflower on the horizon will certainly be getting my respect.

Peter Benfield, Chairman



FOR SALE 1951 MAYFLOWER

**RECONDITIONED ENGINE - RUNS OK
STAINLESS STEEL EXHAUST SYSTEM
SIX MONTHS MOT AND TAX DISC
SOME COSMETICS AND RECHROMING NEEDED
GOOD TYRES AND RUNS WELL
GENUINELY USABLE VEHICLE**

£600 ono

P DEAKIN 01782 848937 (STOKE ON TRENT)

FOR SALE
COMPLETE THIS RESTORATION PROJECT

**1953 COTMAN GREY
MAYFLOWER SALOON**

CAR HAS BEEN STRIPPED TO THE SHELL AND IS VERY SOLID
ONLY MISSING THE ROOF LINING AND DOOR PANELS
ENGINE HAS BEEN REBUILT BUT HEAD IS NOT YET ON
BUMPERS AND OVER-RIDERS ALL PRESENT BUT WOULD
BENEFIT FROM A RECHROME. SEATS ARE IN RED AND ARE
VERY GOOD CONDITION. LOADS OF PAPERS
INCLUDING ORIGINAL REG NO & BUFF LOG BOOK
ASKING PRICE - ABOUT £600

CONTACT RON NORMAN ON 01344 - 622707
5 NORFOLK FARM COTTAGES
THE GREAT PARK, ASCOT, BERKSHIRE SL5 7RZ

Latest picture from John Sobol (695) of his Mayflower

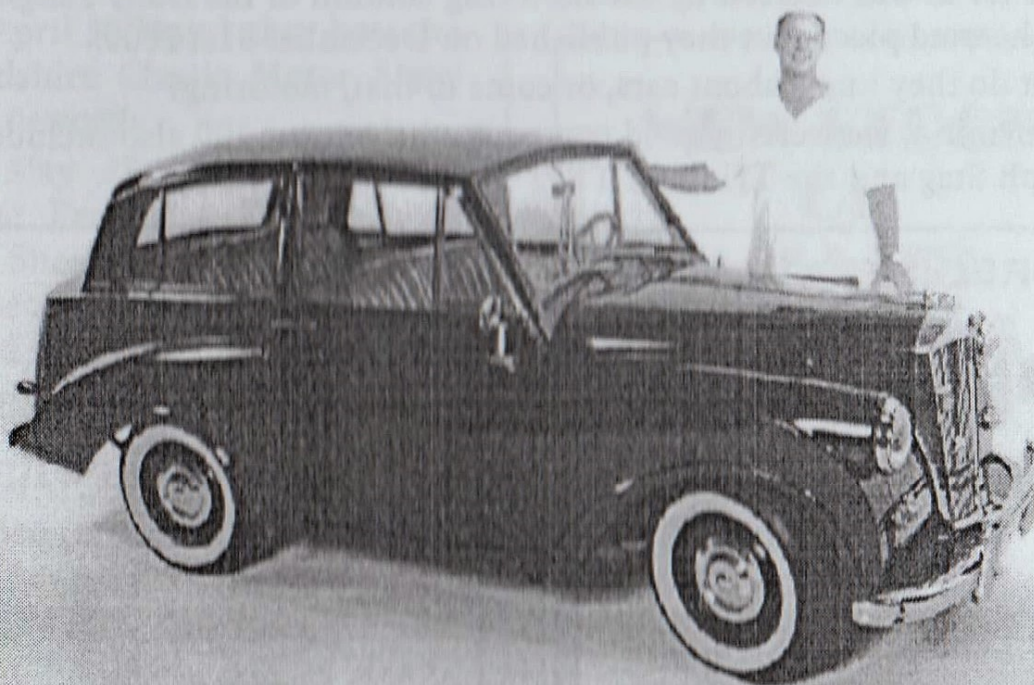

Did you know?

by Phil Benson

LOOKING back through some old programmes etc I discovered that the very first Triumph Mayflower Club Annual Rally was held at Dodington Park in Gloucestershire near Bristol in 1975 (as was the second in 1976).

The programme told me that there has been a large house on the site since 1560.

The celebrated architect James Wyatt working under instruction from Christopher Codrington completed the present house in

1817. The estate was originally granted to a member of the Codrington's family in 1597 by Queen Elizabeth I and has remained in Codrington ownership to this day.

It stands in 700 acres of parklands designed by another equally famous personality — Capability Brown. The house is now home to Britain's finest horse-drawn carriage museum and to a fine collection of model soldiers containing over 14,000 figures.

Perhaps the rally organising committees should consider this venue for a future year's rally.

100 cars of the millennium!

FIRST THE good news — yes, the Mayflower is there.

Now for the bad news. This listed the *worst* 100 cars of the millennium. At least, as far as was decreed by the motoring column of the *Daily Telegraph* in a light-hearted piece that they published on December 31st 2000.

What do they know about cars, or come to that, motoring?

Never mind, we were in good company, their worst 100 also included the Triumph Stag and the Triumph TR7!

REGISTRATION
NUMBER

PKK 101
FOR SALE

Apply:

01322 221493

for details

STOP PRESS

Details of the

Triumph Razoredge
25th Anniversary Rally
just arrived

SUNDAY 16th JULY
BROUGHTON CASTLE

All Welcome

Greenwood's Exhibitions

ONCE AGAIN Greenwood's Exhibitions are promoting a full calendar of top class events for this year.

They make no entry charge for classic cars for the static shows that they organise if you pre-book.

For Static Shows, they start off with the London Classic Motor Show at Alexandra Palace on 18th/19th March. Howard Pryor has been extended another invitation to attend within the Autoglym sponsored Concours section.

Only exceptionally "top quality" vehicles are invited into this section, and to get invited back for the third time in four years tells its own story. Well done Howard.

Exhibitions

On April 30/May 1 they host the Bedfordshire Classic Motor Show at Shuttleworth.

On May 28th and 29th they promote Penshurst Place Classic Motor Show at Tonbridge, Kent. (Phil Benson has booked in to this one and will probably be there on the Sunday.)

On July 16th they run the Kingshurst Bagpuize Show near Abingdon in Oxfordshire.

On August 27th/28th they organise the Breamore House Show at Fordingbridge in Hampshire.

Also on August 27th/28th they organise Knebworth 2000 10th Year at Stevenage, Herts.

Classic runs

Greenwood's Exhibitions also organise two major classic car runs for pre-1979 vehicles.

Sunday 4th June is the London to Brighton Classic Car run (i.e. not the vintage car run).

Sunday 17th September is from Bath to Bournemouth for Post-1940 Pre 1979 vehicles.

For more information you can contact Greenwood's Exhibitions as follows — E-mail: jackle@greenwoods.uk.com; Website: <http://www.greenwoods.uk.com>; Telephone: 01296 631181/632040; Fax: 01296 630394.

They always seem to give a special welcome to Mayflowers so book in somewhere and have a great day out this year.

**NEW STOCK
OF
VALVE
GUIDES
NOW
AVAILABLE**

£3.50 each

From the Spares Secretary

LETTERS

The restoration of NTA 178

NTA 178 returned home on a trailer last November, having finally completed a visit to the spray shop.

I know that I agreed a price based on the work being a 'back-ground' job, but I thought I would see her back long before 14 months had gone by. Be warned. Once you let them go out of your own control there is not a lot you can do to hurry things up. I make no complaints at all on the workmanship. For a back-street spray shop the quality is excellent. At least, any delays from here on in will be down to me.

Over the Christmas break I finally plucked up the courage to make a start. How does one start to work on such as this gleaming shining object?

I had almost been frozen with fear of accidentally bumping into the car body, as mine is a very narrow garage. Taking the bull by the horns I got the new wiring loom out of the box, and working indoors spread it from the Christmas tree to the kitchen door via the hall. I managed to identify all the major tentacle ends. Using the wiring diagram from the workshop manual is a pain because the printing is so small.

Having been there before with JBD had prepared me. I had photocopied the page up to A3 size and this really helped.

The next day the loom and I boldly moved into the garage. Starting from the front near-side and working clock-wise towards the rear near-side I managed to get the loom in place in just over three hours. I put the dust cover over her then and retired back into the warm. Apart from stripping and cleaning up the brake master cylinder ready for refurbishment with a set of new seals etc that took me past January.

I'll be in touch!!

Phil Benson

DON'T FORGET THE AGM

Sunday 26th March 2000
at Alumwell Junior School, Primley Avenue, Walsall
from 2.00 pm till approx 4.30 pm

Mayflower on a rope

Dear Phil,

Returning home one Saturday morning from work after fixing an on-going central heating problem at a customer's house, feeling quite pleased with myself knowing that I could now present my bill, I pulled off the notorious M25 at Potters Bar on my way to Barnet when I saw this Mayflower on a tow rope in front of me. So instead of turning left to go home I turned right and followed.

They were going quite slowly and probably thought I wanted to

pass but I stayed behind until they came to a stop outside a house.

I climbed out and swiftly introduced myself and started to chat!! It appeared that this Mayflower had been garaged since the 1960s and had remained there for over 30 years.

It is complete and in quite good condition considering. Further conversation revealed that Roger Turpin, that's the owner's name, had a 1939 K2 Austin mobile canteen Naffi Van. Just then my brain clicked into gear, as we are going to Bletchley Park for our 2000 Rally (which is in part a military museum) and last year we offered free morning and afternoon tea why not serve it from a Naffi Van.

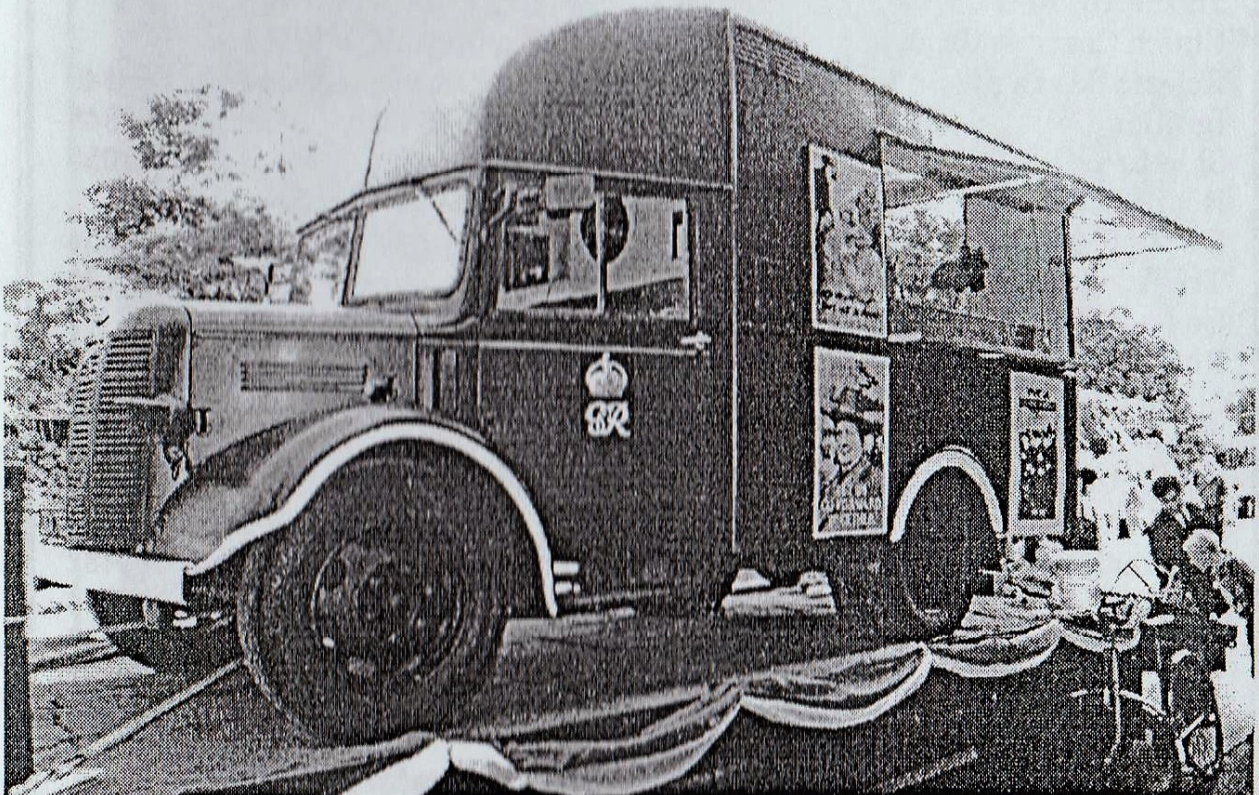

Roger Turpin's Naffi van

Roger is seriously considering this proposal and I am doing everything I can to persuade him by offering every assistance I can with his car.

He now has the Mayflower running and it sounds quite sweet. There is still lots to do but Roger appears quite enthusiastic. Let's hope he finishes it and joins the club.

It amazes me that 50 years after Mayflowers were produced and 25 years of the Mayflower Club these cars are still being found.

I hoped my introduction was a friendly one, indicative of our club, as I know that every member would have done the same and offered every assistance they could.

Howard Pryor

NEW PARTS AVAILABLE

Thrust Washer	100327	Clutch/Brake Grommet Plate	101335
Timing Chain Tensioner	42425	Steering inner column & cam	500272
Valve Tappet	100321	Steering Cork Seal	500273
Core Plug	102970	Door Frame Channel, front	600210
Core Plug	100373	Striker Plate	601021
Spiral Gear	102337	Jacking Socket Plug	101884
Idler Bracket	102201	Door Handle	600627
Idler Lever	103388	Axle Shaft with hub assembly and back plate	
Oil Seal	58224	Axle Shaft with bearing etc	
Shock Absorber	106152	Headlamp Rubber Washer	
Clutch Cover Assembly	500257	Radiator Grille, lefthand	800149
Release Bearing	501009	Fuel Pipe to carb	200345
Ignition Coil	200327	Oil Pipe	101050
Side Lamp	61834	Carburettor Gasket Set	
Roof Lamp Glass	600502	Driving Mirror	700354
Distributor	200326	Bonnet Handle	700120
Trafficator	58029	Interior Door Handle	
Control Box	101951	Vent Lever	600182
Roof Lamp	600500	Vent Catch Plate	600181
Speedometer	200499	Number Plate Lamp	500492
Choke Cable	400019	Windscreen Wiper Switch	58036
Starter Cable	400030	Tail Light Seating Rubber	500497
Master Cylinder	300868	Speedo Cable	600482
Handbrake		Track Rod End	100914
Petrol Pump	200141	Bottom Trunnion	101557
Air Filter Grommet	101784	Top Ball Joint	200771
Water Pump Seal	100858	Lower Wishbone	200456
Clutch/Brake Grommet	101336		

Details from the Spares Secretary

FOR SALE
1952
TRIUMPH MAYFLOWER

Comet Blue with Blue Interior

Past concours winner

Owned for 22 years as only the second owner

Has only covered 8,000 miles since restoration

Stainless steel exhaust system. Excellent chromework

MoT until January 2001. Many new parts fitted

New arrival forces sale

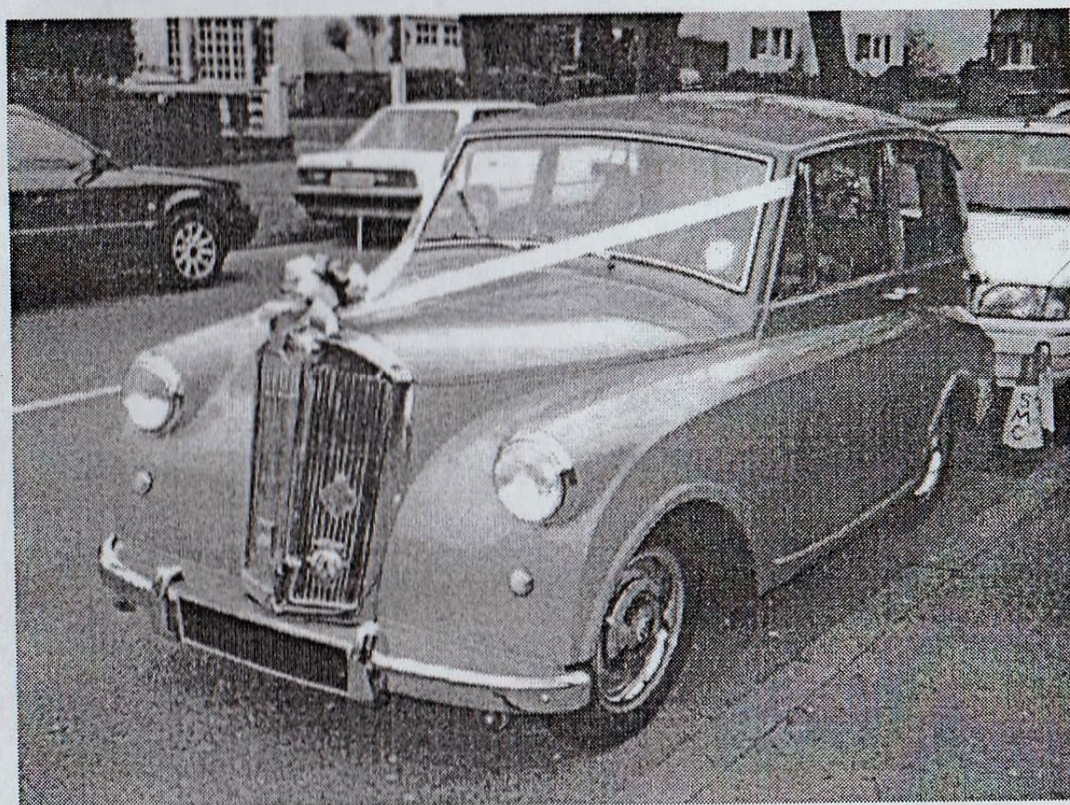

Enquiries to:

01322 221493

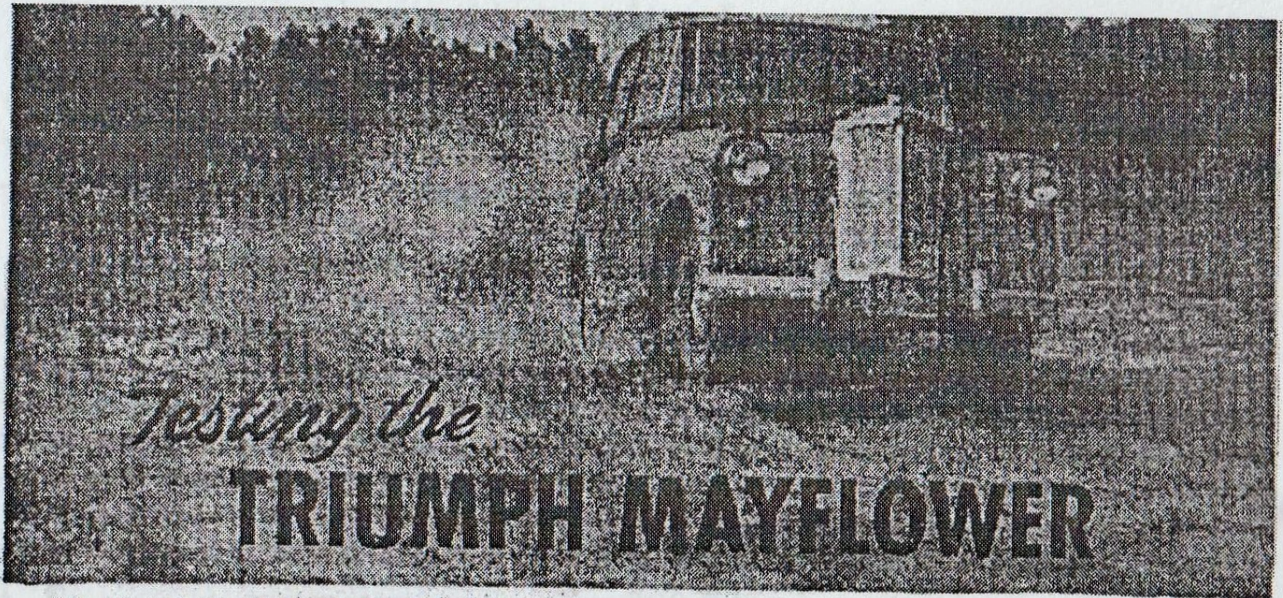

Testing the
TRIUMPH MAYFLOWER

Triumph took 35 minutes of this rugged lugging through the sand traps without excessive engine heating or any sign of chassis weakening.

YOU may or may not have a quarrel with the razor-edge styling of this little English car—that's a matter of the style you prefer. Personally we feel that the Mayflower designers tried to produce something reminiscent of a scaled-down Rolls Royce, and the Rolls doesn't have the type of lines that scale down harmoniously. The purpose of these Science at the Wheel reports, however, is not to burden you with our ideas about styling. Instead the tests conducted for us by the independent Motor Vehicle Research laboratory give you the facts about how the car performs and how it is built, and let you decide for yourself whether the car we report on is the one you want.

What is impressive about so many of these small imported cars is the true craftsman's attention to small details, small comforts and the elimination of small annoyances that goes into them. Rather than giving you gas-gulping high speed and acceleration, the British designers usually give you a precision-made small engine that gets you there on as little fuel as possible, plus good tools

Front seat area showing (A) fulcrum-type foot pedals, (B) open area glove compartment, (C) how entire seat moves up and forward allowing rear seat passengers ample entry space, (D) sunken floor in rear for more foot space, (E) slot for jack to fit in, (F) folded in semaphore-type direction signal, (G) small rear view mirror, (H) door handle within too easy grabbing distance for safety.

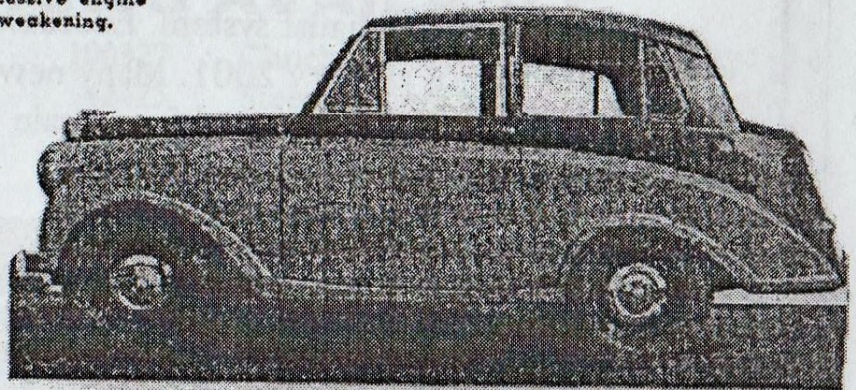

Styling of this Triumph is certainly unique. Quality of finish on car tested was excellent as was the careful attention to many details.

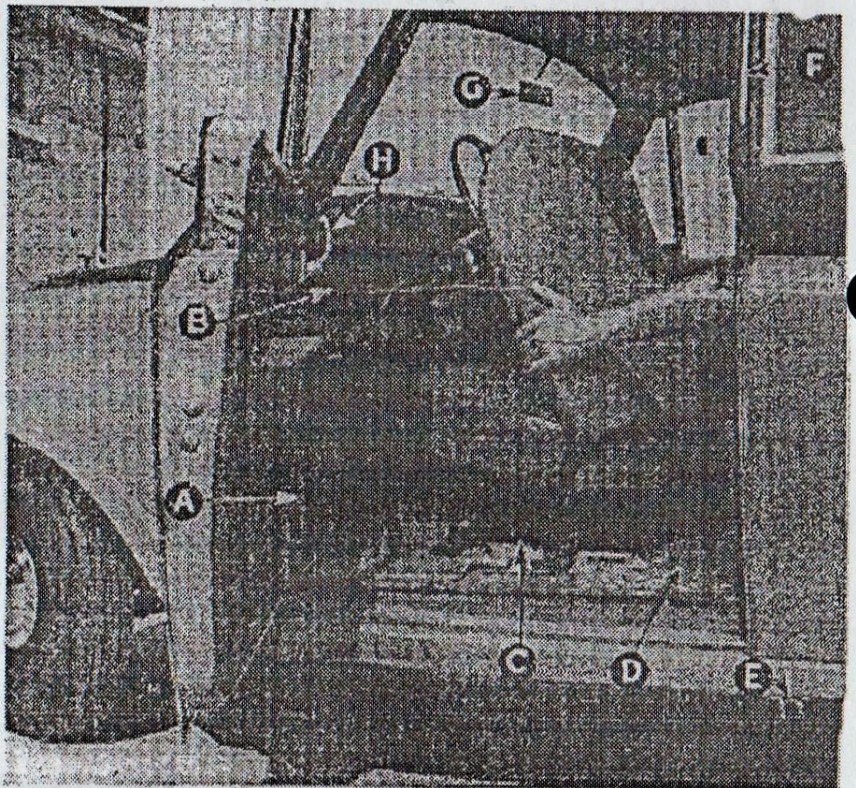



Raising rear end to show how spare tire fits into special holder below the trunk. Holder swings down to release tire when locking nut inside trunk is released.



Oil intake cap tells you just what types of oil can be used in this car at handy location.

and convenient servicing points that mean you can make many simple adjustments yourself, and keep your repairman from having to add costly time to his bills—just getting at the source of the trouble.

Take this Triumph as an example. In the MVR tests, her true top speed was only 63 mph but her gas mileage on the measured 5-gallon run averaged an excellent 29.4 mpg. At



Both hood and gas tank can be locked to prevent fuel loss or engine tampering. Extras like these are plentiful on this Triumph.

Drivers' Observations

ROADABILITY: Good cornering and road holding, and a very smooth ride for so small a car. Tire howl on fast corners very low. Wind noise level is medium at 50 mph. Engine roar at a minimum up to 50, increases sharply above this speed. There is low road shock to the steering wheel. No failures were experienced in the most rugged tests, although the front suspension bottomed at low speeds on the crossies.

RIDING COMFORT: For such a small car it is very good, with ample room from both the driver and passengers' standpoint. Quality construction holds the rattle-squeak level low. Plenty of room for driver's thigh to clear steering wheel when applying brakes; rear compartment floor is sunken to provide more leg room. Hand-brake lever located on left of steering wheel can jam driver's hand against the underside of dash when applied. Windshield reflection pickup includes steering wheel and shift lever in the daytime. Instrument cluster reading very good at night, but dash lights cannot be dimmed. Speedometer located at far right of instrument cluster (original design was for right-hand drive), picked up intermittent reflections during daylight, reducing ease of reading. At speeds above 50 mph, a pronounced draft hit the driver's neck. Leather and plastic upholstery material appeared to be good quality. Vision was good in this car. Heater is excellent and is designed to take in air through the cowl vent, eliminating the possibility of sucking carbon monoxide

from any car in front of it—a very worthwhile safety feature.

INSTRUMENTS AND CONTROLS: Full-type starter button and windshield wiper control on dash, easy to reach. The speedometer is equipped with a regular and a trip odometer; the latter can be reset by a small knob on the right hand side of the dash cluster. The temperature gage is calibrated in centigrade rather than fahrenheit. Dimmer switch to left of clutch easy to get to and to operate. Action of the accelerator is sensitive. Direction signal controls located on top of horn button. The transmission is a standard three-speed, with steering column gear shift lever.

HARMONIC BALANCE POINT: (best cruising speed as determined by the "feel" of the car to the driver). 35 mph indicated in top gear on level road.

SPECIAL COMMENTS: The enamel finish on this car was excellent, showed minimum orange peel effect. The door handles and the window frames which also form the tops of the doors are solid brass, heavily chrome-plated. Hub caps are finished on the inside with a special plastic paint to prevent rust. Motor, transmission, and spring shackles rubber-mounted. The car produces very little vibration. Counter-balanced hood operates easily. The trunk door, hinged at the bottom, can be left down like a tailgate in order to carry unusually large loads. With lid in this position, tail light and license plate swing down so they may be seen.

a steady 30 mph she recorded 39 mpg which is about as good as the best figure we have recorded to date. On acceleration, it took 33.68 seconds to go from standstill to 60 mph, proving that this Triumph is certainly no thunderbolt.

Sometimes, however, the car that can hold a good steady speed on curves as well as straight-aways gets there just as soon as the speedster that has to slow down to take the curves. How does this Triumph do? It took the curves fairly well and managed a driver-estimated maximum safe speed on a paved 400 ft. circle of 41 mph, which, in all fairness, is no better or worse than what many American cars did on the same test. On the regular road runs this little import had steady, stable road manners,

FLOWER POWER

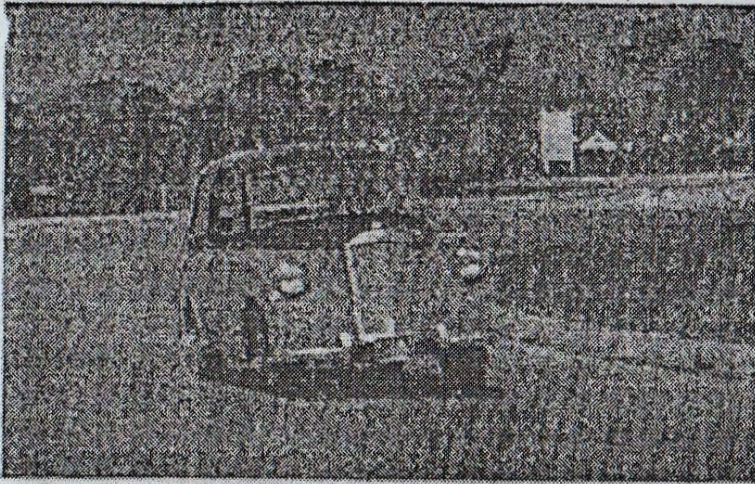

The driver-estimated maximum safe speed on this 400 ft. circle was 41 mph, which is what the Triumph is doing here.

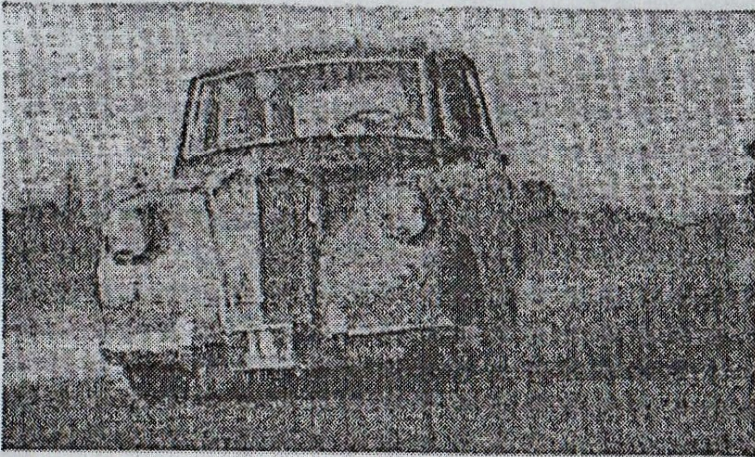

Triumph makes a panic braking stop. Her braking ability was good and fading was at a minimum throughout the tests.

with a minimum tire howl on the curves. As for stopping ability, this car had good braking characteristics and showed a minimum amount of slewing or fading, even after repeated panic stops.

How about those small details that mean a lot to the type of owner who is not in an eternal hurry, trying to beat his neighbor's Mercury away from the stoplight? This relatively low-cost Triumph (\$1750 f.o.b. with heater at the nearest port of entry) has a good share of such thoughtful features. For instance, there's a key-locking hood, an oversized oil bath air cleaner, locking gas cap, clips to hold your luggage secure in the trunk, a very complete set of tools (including a non-slipping jack which allows you to change a tire in your Sunday best) and that old-fashioned implement long extinct on this side of the Atlantic, a crank. The next time the thermometer bumps the zero mark and your starting motor can't budge the engine, think of that crank.

The frame of this car is clean and rugged, and the hydraulic brake lines and linkages are well protected. The body and frame are united by welding, giving a unit type of construction that proved very durable, withstanding the worst we could give it in the torture chamber and rough track tests. Only the garnish molding loosened

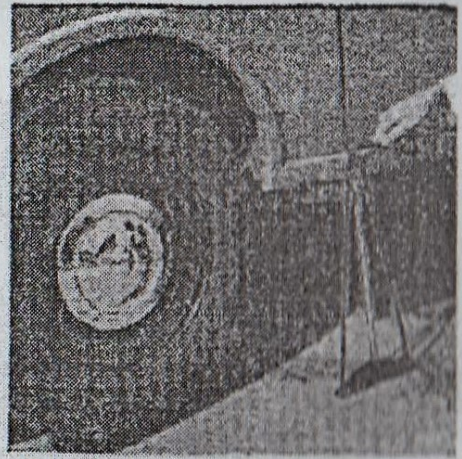

Jack fits into one of four lugs on the body works easily.

due to production faults, but this was easily repaired with a screwdriver. Incidentally, your serviceman will not have to be a double-jointed contortionist to service this car, since the key servicing points are easy to reach and adjust.

There are some features in this car's design and production which could have been improved upon. The possibility of vapor locking is present in this car because of the unprotected fuel line between the pump and the carburetor. Some of the wiring almost touched the engine block. This could cause rapid deterioration of the insulating material.

Our MVR technicians were quite surprised when what appeared to be

watertight construction leaked excessively at several points when two 2½ inch hoses with 100 pounds pressure soaked the car more thoroughly than a heavy, hard cloudburst. The side windows and vent panes leaked as badly as those on any vehicle tested to date, and the windshield had several leakage points. Other seam areas showed comparatively little leakage and the car started and was driven away immediately after the test, indicating that even in the worst rainstorm the engine wouldn't stall.

How safe would this car be in the event of an accident? Probably as safe as the average. It is a well-built car, but it uses a three-spoke steering wheel (whose bottom spoke might impale the driver if the wheel rim breaks off). Also, the front door handle is positioned in front of the arm rest in such a way that it might be grabbed and the door opened in case of a sudden stop or slow down. Then there is that matter of the one-speed electric windshield wiper—adding another speed would give you that change of pace that helps to keep you alert during those long rainy drives by varying the wiper stroke speed.

However, these complaints are commonplace ones, and the general level of construction in this car is of very high quality.

Rally news

by Howard Pryor, Rally Secretary

AS WE GO to press arrangements are already well in hand for our Year 2000 Annual Rally. The date is set for 25th June at Bletchley Park, Milton Keynes in Bedfordshire and will be held with the Early Triumph Clubs (nicknamed the ETCs).

The discussions at the special meeting in Walsall on 28th November 1999 brought about many new ideas for the Millennium Rally in addition to our usual items.

We sought a new competition and Phil Benson came up with the idea of a "back seat memorabilia" theme. So start thinking and collecting and join in. May be a newspaper of the day your car was first registered, a coronation display, any items you can get *inside* your car. There will be a special prize for the best car chosen by Mrs George Jeary (to be confirmed).

Bletchley Park is advertised as Britain's best kept secret, being the site of the Enigma code-breaking in World War II. It hosts a military museum inclusive of vehicles, German command post, model railways, fire engines, model boats, toy collection, a Churchill collection and much more.

Tours are free of charge every hour on the hour on the day of the rally. There will also be a model boat race on the lake in front of the main house.

Our concessionary entrance fee for the day will be £3.50 for car and driver with one passenger free, against a usual fee of £4.50 per adult.

We have now booked the ballroom in the main house at Bletchley Park for our combined pre-rally dinner and dance on Saturday 24th June. Tickets will cost 20 gns each for a three course dinner with cheese, biscuits and coffee.

As this a special year and also the 25th anniversary of the TMC a band or a disco is being hired for your evenings entertainment. Please phone if you are interested as soon as possible, we need numbers to be able to put this on. Last year approximately 50 people attended the dinner.

Thirty rooms at the Furzton Lake Hotel in Milton Keynes have been reserved for the Triumph clubs at a special concessionary rate of £30 per double room for Saturday 24th June. Please telephone me (020-8440 8623) to book you room and/or dinner tickets without delay. Remember the rooms and tickets are for *all four clubs*.

Apart from our new Top Six Awards, Distance Awards, etc, the barbecue will be back (hopefully!).

The very successful raffle and tombola is being organised, if you have a prize to donate it will be gratefully received (it would be nice if one small prize could be donated from each member) it all helps and proceeds all go to rally expenses.

It is now 50 years since Mayflowers were produced and it is hoped to put on a special display with a Mayflower on a turntable (similar to the early Motor Show example) with one side showing memorabilia of the 1950s and the other showing up-to-date items.

A special 50 year Mayflower cake is being made by Sue and Peter Benfield (more Sue I hope! Sorry Peter) to be cut and given away at Bletchley with the free morning and afternoon teas.

Start planning now and remember it's 25 years ago that the Mayflower Club was born, so let's have at least 25 Mayflowers at Bletchley! We can do it.

Thanks to Dave Miller and family for showing his car at the Triumph Spares Day at the NEC Stoneleigh. A good day was had by all who attended.

I am sure you all know, but just in case you didn't, Dave's car is featured in the current issue of *Triumph World*.

Geoff Evans also attended but sadly he was there to sell his car, due partly to ill-health and trying to reduce his fleet.

Members attending last year's annual rally at Burford may remember Geoff's car as being very original complete with rubber mats and only 20,000 miles on the clock from new.

We need a show car for the Early Triumph Stand at Brighton on 28/29th May 2000. Anyone interested please contact me.

Happy Mayflowering, see you at the AGM.

The club has a limited number of

TRACK ROD OUTERS

(Part No. 102692)

Limited to one per member, first
come first served basis

Please contact the Spares Secretary for details

Welcome to Bletchley Park

Britain's Best Kept Secret

You can see:

- In Faulkner House
- Aircraft Recovery
- American Army
- Cinema Projectors
- Colossus Rebuild
- Computer Exhibition
- Cryptology Trail
- Diplomatic Wireless
- GPO's Automatic Radio
- German Command Post
- Home Front
- Ox & Bucks Infantry
- Radar & Electronics
- RAF Halton
- The Shop
- Uniforms

In Hut 11a

- Model Railways

In the Garages

- Fire Engines
- Model Boats

In the Mansion

- Churchill Collection
- Toy Collection
- Tours start in the Library

In Hut 4

- Cafeteria and Bar

In the Motor Pool

- Military Vehicles

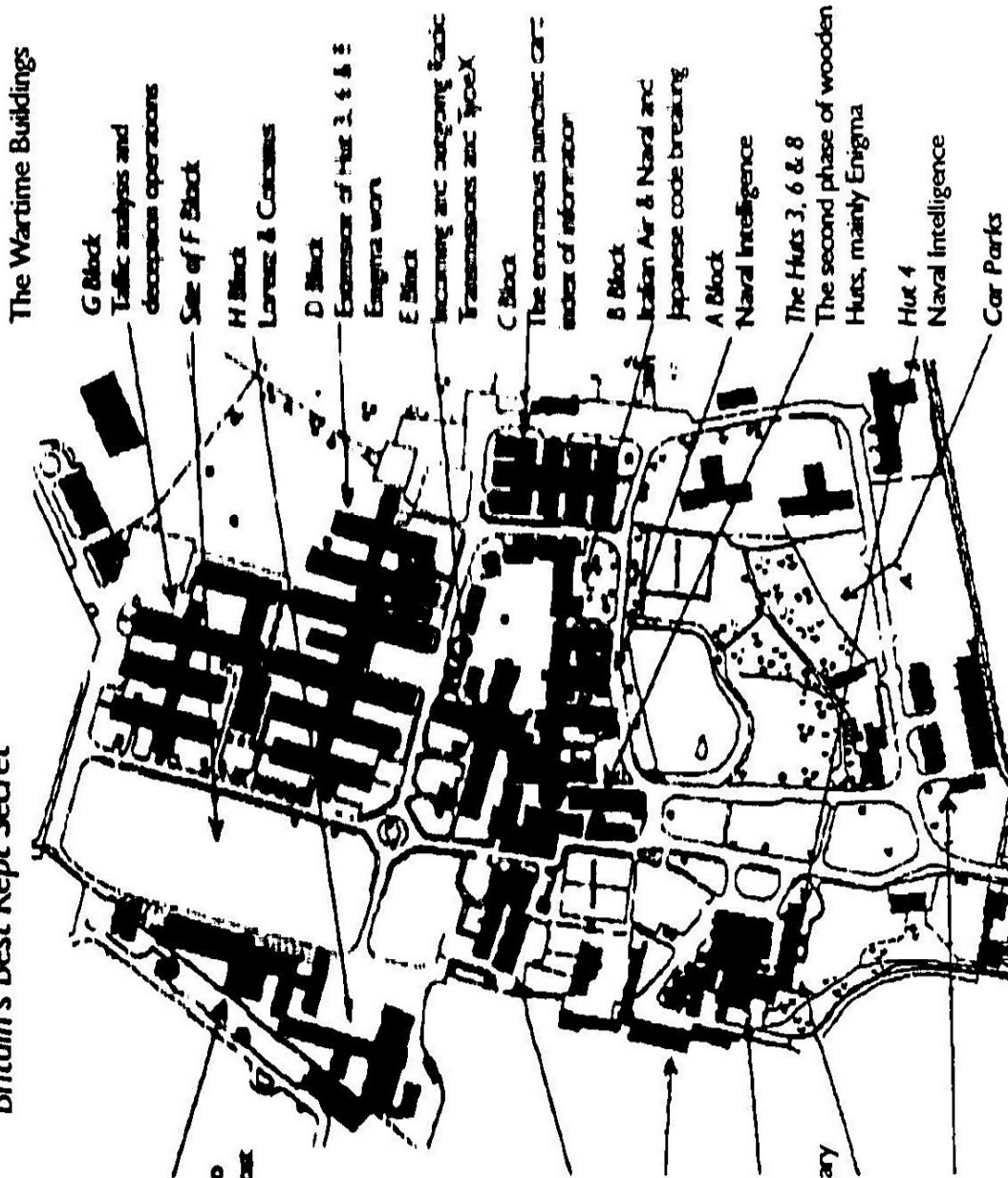

The Wartime Buildings

G Block
Traffic analysis and
deception operations

Site of F Block

H Block
Lenses & Circuits

D Block

Extension of Hut 3, 6 & 8

Engine work

E Block

Incoming and outgoing traffic
Transmissions and 'spaceX'

C Block

The enormous punched card
index of information

B Block

Italian Air & Naval and
Japanese code breaking

A Block

Naval Intelligence

The Huts 3, 6 & 8

The second phase of wooden
Huts, mainly Enigma

Hut 4

Naval Intelligence

Car Parks

Main Entrance

Club Internet Web Site launched

<http://www.triumphmayflowerclub.com>

OUR world wide web site has now been launched. You can find it on the internet at the following location — <http://www.triumphmayflowerclub.com>.

As anyone who has seen it so far will testify this is quite a modest offering. However, it is being improved month by month and eventually will hold lots of information about the Triumph Mayflower Club, the Triumph Mayflower car itself and lots of links to other sources of useful information, technical, spares, other clubs, etc.

The club has just had the

EXHAUST GASKET

(Part No. 32301)

manufactured

To get these made at a reasonable price we had to have a large number. Please help the club by purchasing a spare gasket

Contact the Spares Secretary

It's a bit like publishing a large book one page at a time. We are hoping to get some feedback from you folks out there as to what we want to put on it. One idea that occurs to us is that we can have regional pages, telling members in the region what is going on, where the best shows and autojumbles are to be found. Where's a good place to go for Sunday lunch, whatever, it's up to you.

What is a region? Well at a guess that's a few big questions. It's got to be all about location of membership. Maybe mainland Europe is only one, or at most two.

England can be broken into about four regions, eg Northern, Midlands, South West, and South East. However, Wales and Scotland are probably just one each.

USA might be split up by East and West while Australia and New Zealand might as well be one each too. Anywhere else tags on where they want.

What should be the driver of these regional pages — why you, of course, all you have to do is to tell Phil Benson what is going on in your region and he'll get the page set up. The more info he gets, the more pages get set up. Simple.

The other reason we have to have a site is so that it can be our free advert to the world. More and more folks use the web every day.

We are increasing by about 11,000 people more per day in the UK alone according to the latest

figures. It must be at least 10 times that rate worldwide.

Steve Coulman has been busy clicking away with his digital camera and has a load of photos he's about to pass on to Phil for use in the website. You should see some of them soon. If you have any you like, don't be shy, send them in. We can be E-mailed on tmclub@triumphmayflowerclub.com so

you have no excuse if you are connected.

One other big advantage to the website is that it can be found anytime of day — local time to you wherever you live in the world. No need to work out those time differences, and rework them when summer time starts! Always very confusing.

Keep those ideas coming in. This area is new to all of us.

FOR SALE

**POSSIBLY THE LOWEST GENUINE MILEAGE (19,800)
AND THE MOST ORIGINAL CONDITION**

1952 MAYFLOWER

(INCLUDES ORIGINAL RUBBER MATS)

THE VEHICLE IS TAXED AND MOT TESTED

**I AM ONLY THE SECOND OWNER AND ACQUIRED THE
VEHICLE IN 1982. NO WELDING HAS BEEN DONE OR IS
NEEDED. WAS IN MUSEUM FOR SEVERAL YEARS**

**COMES COMPLETE WITH ORIGINAL BILL OF SALE AND
SERVICE RECORD BOOK**

COMPLETE HISTORY OF VEHICLE KNOWN

**A UNIQUE VEHICLE WHICH DESERVES AN ENTHUSIASTIC
OWNER**

**SALE DUE TO OWNER HAVING TO DISPOSE OF PRIVATE
COLLECTION FOR HEALTH REASONS (AND AGE!)**

**CHERISHED NUMBER ALSO AVAILABLE BY SEPARATE
NEGOTIATION**

PLEASE CONTACT GEOFF EVANS - CLUB MEMBER 876

EXPECTED PRICE £2,500.00

TELEPHONE: 01527 546530 ANYTIME

FLOWER POWER

March 31, 1954

The Motor 29



I know



Being England's leading agents for ROVER, JAGUAR and many other fine cars, gives HENLYS the added advantage of acquiring the best of used models, and providing an incomparable selection. Here are some examples:—

1949 ARMSTRONG SIDDELEY Lancaster S/Saloon, bit.	Black	£625
1952 ARMSTRONG SIDDELEY Whitley Saloon	Black	£825
1949 AUSTIN A40 Devon S/Saloon, heater	Grey	£495
1951 AUSTIN A70 Hereford S/Saloon	Black	£795
1950 CITROEN L1. 15 S/Saloon	Black	£625
1948 DAIMLER 2½ Saloon	Black	£665
1952 DAIMLER 2½ Consort Saloon, radio	Grey	£1,025
1951 FORD Pilot Saloon, heater	Blue	£495
1950 HILLMAN Minx Ph. IV Saloon	Black	£395
1953 HILLMAN Minx Ph. V D/H Coupe	Blue	£635
1953 HUMBER 16 Hawk Saloon	Black	£845
1949 HUMBER 27 Super Saine Saloon heater	Black	£445
1946 JAGUAR 1½ S.E. S/Saloon, radio	Black	£545
1949 JAGUAR 3½ S/Saloon	Black	£595
1951 JAGUAR 3½ Mk. V S/Saloon, radio	Black	£825
1952 JAGUAR Mk. VII. S/Saloon, radio	Gunmetal	£1,245
1950 MORRIS 6 Saloon	Mintoon	£470
1953 MORRIS Oxford Saloon, heater	Black	£635
1952 RILEY 2½ Saloon, heater	Grey	£595
1946 ROVER 16 4-lt. S/Saloon, radio, heater	Black	£545
1953 ROVER 75 Saloon	Blue	£1,075
1952 ROVER Land-Rover, heater	Green	£445
1947 STANDARD 12 Saloon	Black	£345
1953 STANDARD Vanguard Ph. II Saloon, heater	Light Green	£725
1953 STUDEBAKER Champion Regal 4-door Sedan	Green	£1,575
1951 SUNBEAM-TALBOT 90 D/H Coupe	Gunmetal	£735
1948 TRIUMPH 1800 Saloon	Grey	£475
1950 TRIUMPH Mayflower Saloon, heater	Maroon	£525
1951 TRIUMPH Renown Saloon	Black	£695
1948 VAUXHALL Velox Saloon, radio, heater	Black	£475

7 Days' Free Trial. All Cars Guaranteed. Deferred Terms.



Head Office: Henly House, 385, Euston Rd., N.W.1
 Telephone: EUSTon 4444
 Devonshire House, Piccadilly, W.1.
 Telephone: GROsvenor 2287
 Henlys Corner, North Circular Road, N.W.11.
 Telephone: FINchley 0081
 Henlys Roundabout, London Airport, West Hounslow
 Telephone: HOUnslow 3454
 182, London Road, Camberley.
 Telephone: Camberley 77

30 Depots throughout the country.

he knows



she knows

YOU CAN

RELY ON...

HENLYS
 England's Leading Motor Agents

LEFT OF RIGHT
 GEAR CHANGE LEVER
an article from November 1951

THE Standard Vanguard, Triumph Renown and Triumph Mayflower are all fitted with steering column gear change levers. During the past two years the position of these levers has been standardised with the lever pointing towards the centre of the car, whether the driving position is right or left-handed. This coincides with most other makes of cars whether English or American.

We are frequently asked by owners if it is possible to alter the gear lever position to operate from

the opposite side, usually because of some disability of the left hand.

It is not unduly difficult to change the lever from one side to the other and anyone of a reasonably mechanical turn of mind should be able to make the alteration.

We illustrate the two slightly different types of gear levers; Fig 1 is the earlier type and Fig 2 shows the slight modifications which were introduced in later models. Their construction can be clearly seen and with the aid of the following

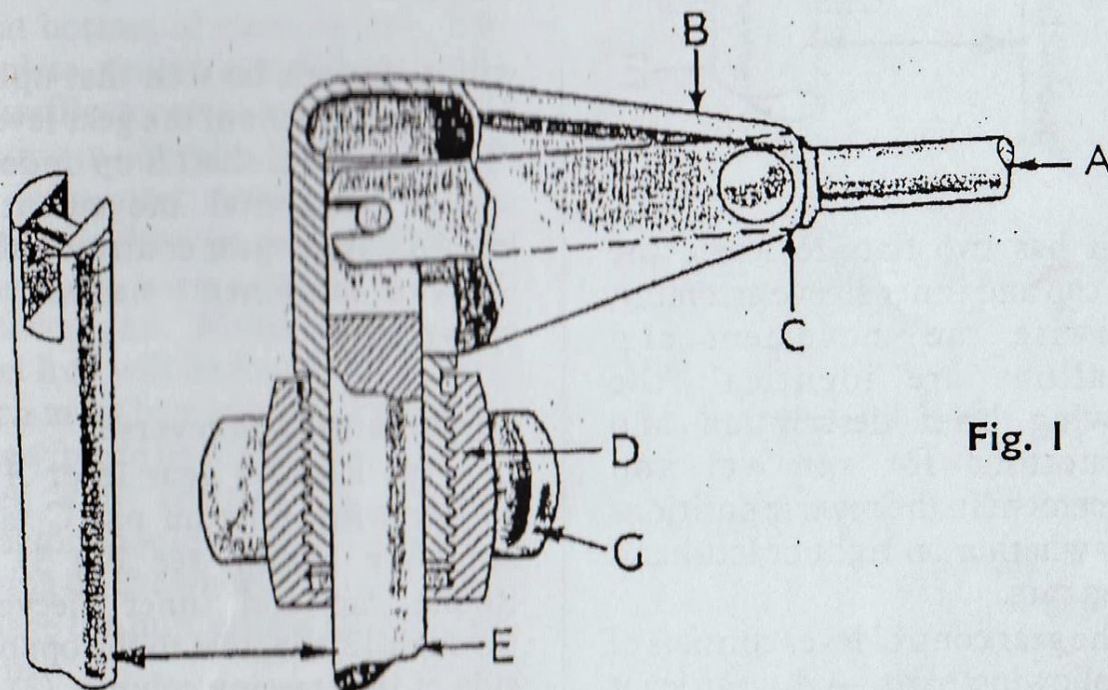

Fig. 1

description we hope those who wish to change their control will be able to carry out the work without undue difficulty.

The only difference between the two types is that in type 1 (Fig 1) the end of the lever is forked and fits into the forked end of the gear control shaft, the fork on the lever fitting over a small pin. In type 2 (Fig 2) the end of the gear lever is rounded and this fits into a hole, *H*, in the gear control shaft, the top of

and knob assembly. *B*, lever cap and inner sleeve assembly which is screw threaded and screws into the bush *D*; this is fitted in *G*, the gear lever clamp; which secures the assembly to the steering column. These two parts, *B* and *D*, are not screwed together completely, consequently *B* is free to rotate in either direction in *D*. The control shaft *E* passes freely through *D* and *B*. Gear lever *A* engages *E* near top of shaft, secured by fulcrum pin *C*.

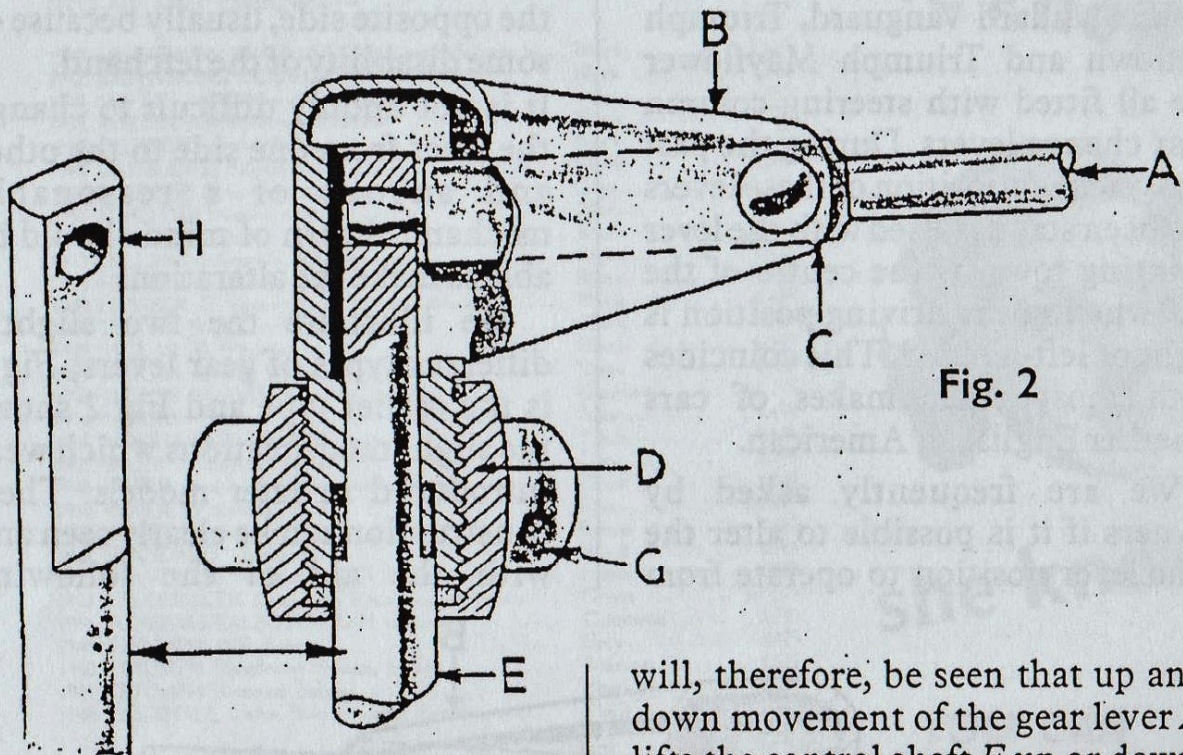

Fig. 2

which has two flats to locate the lever cap and inner sleeve assembly, otherwise the movement and operations are identical. the following brief description and instructions for removal and replacement in the reverse positions apply whether on right or left-hand driven cars.

The gear control lever consists of the following parts — *A*, gear lever

will, therefore, be seen that up and down movement of the gear lever *A* lifts the control shaft *E* up or down, whilst horizontal movement of lever *A* rotates gear control shaft *E*, the two movements necessary to change gear.

To dismantle and reverse

(1) Remove gear lever *A* by withdrawing fulcrum pin *C* (after removing circlip, see Fig 3). (2) Rotate cap and inner sleeve *B* through 180 degrees to the opposite side of the steering column. (3) Re-

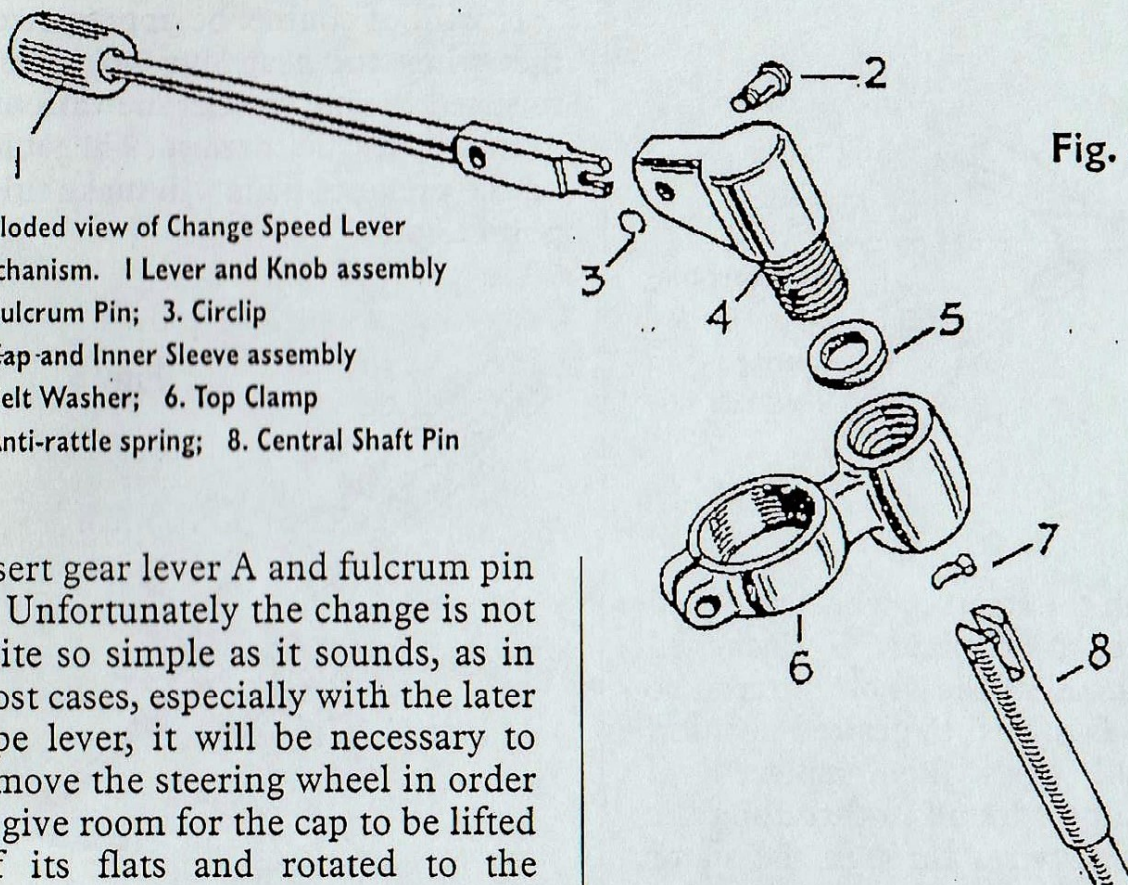

Fig. 3

- Exploded view of Change Speed Lever mechanism. 1 Lever and Knob assembly
 2. Fulcrum Pin; 3. Circlip
 4. Cap and Inner Sleeve assembly
 5. Felt Washer; 6. Top Clamp
 7. Anti-rattle spring; 8. Central Shaft Pin

insert gear lever A and fulcrum pin C. Unfortunately the change is not quite so simple as it sounds, as in most cases, especially with the later type lever, it will be necessary to remove the steering wheel in order to give room for the cap to be lifted off its flats and rotated to the opposite side.

Removing the Steering Wheel

To remove the steering wheel we refer to sketches 4, 5 and 6. First remove the three screws indicated in steering wheel hub, and gland nut at bottom of steering box. The complete centre control for horn and trafficator switches can then be withdrawn after the connections for the horn and trafficator wires, which pass through the centre of the stator tube, have been detached at the lower end. Within the steering wheel hub will be found a large nut which must be removed. The wheel is then free to be withdrawn from its taper and splines. A proper extractor should be used for this as tapping on the wheel hub may easily damage the hub, unless great care is taken.

Gear positions — lever pointing towards centre of car. Right or left-hand steering	Gear positions — when lever reversed
Top — Down and back	Top — Down and forward
2nd — Down and forward	2nd — Down and back
1st — Up and back	1st — Up and forward
Reverse — Up and forward	Reverse — Up and back

Fig. 4

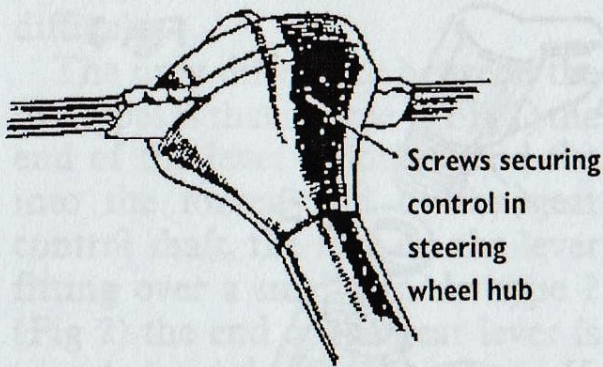

Screws securing control in steering wheel hub

With the steering wheel removed and securing clamp *G* slackened (Figs 1 and 2), the whole unit can be lifted, *B* turned to desired position and all parts then replaced. If difficulty is found in threading the electrical wires through the stator tube a wire may first be threaded through, the wires attached to this and pulled through like a cleaner in a rifle barrel.

It will, of course, be appreciated that when the gear lever has been reversed the position of the various gears will also be changed. The table on the previous page will make this point clear.

Fig. 5

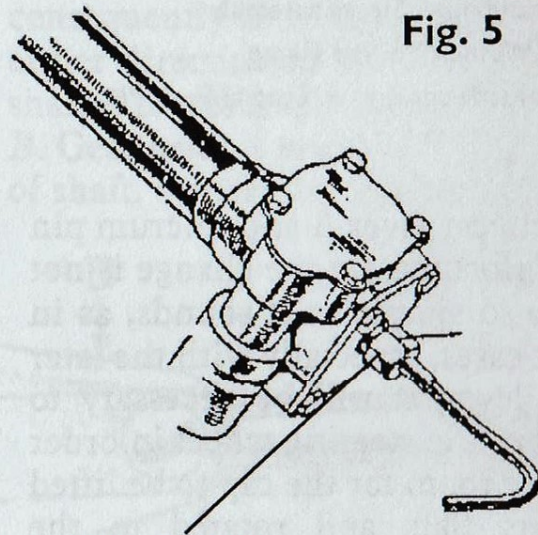

Gland nut and gland for securing stator tube

Fig. 6

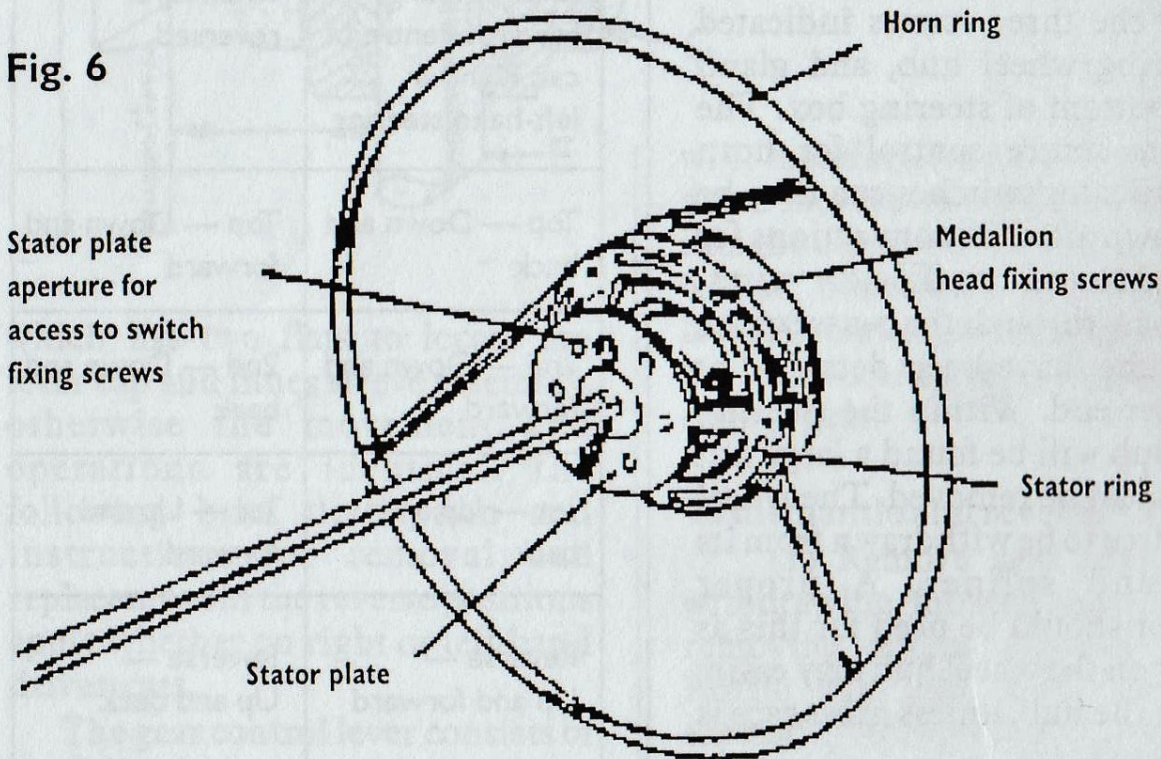

Stator plate aperture for access to switch fixing screws

Horn ring

Medallion head fixing screws

Stator ring

Stator plate

Classic Car Sills

Parts for the Triumph Mayflower

Ken
Teleph

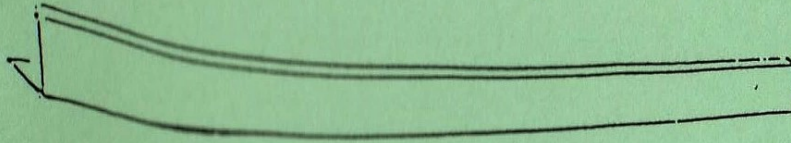

Triumph Mayflower
SILL £20.00

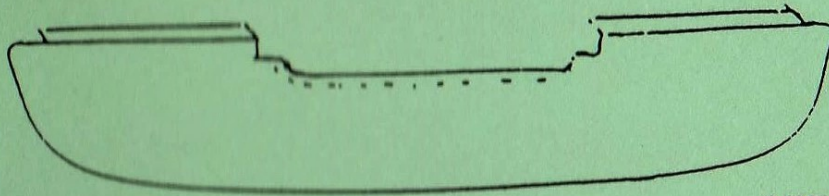

FRONT
APRON £45.00

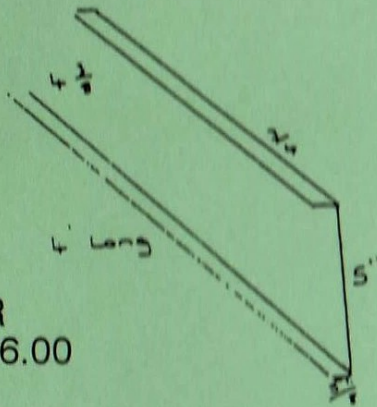

INNER
SILL £6.00

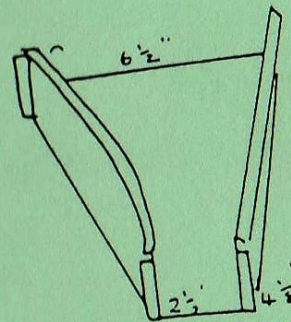

OUTRIGGER
£7.50

INNER SILL £6.00

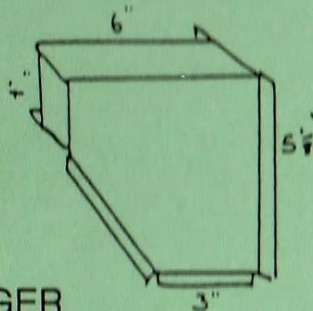

OUTRIGGER
£7.50

REAR SPRING
CHASSIS
£7.50

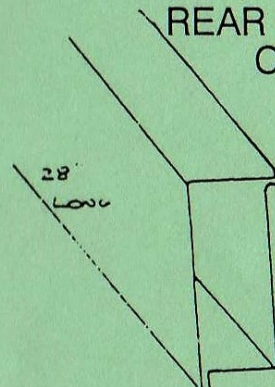

J. COLLIER

4 Mortimer Road, Kempston, Bedford MK42 8RE
Tel: 01234 840958 (Evenings) or 01480 477530 (Works)

