

Triumph Mayflower Club



Worldwide Membership

WINTER ISSUE 1999 No. 94



FLOWER POWER

THE TRIUMPH MAYFLOWER CLUB

Club Officials for 1999-2000

| | |
|---|--|
| CHAIRMAN | Peter Benfield, Amberley, Crindle Carr Lane, Thornton-le-Moor, Northallerton, N. Yorks DL7 9DZ |
| VICE CHAIRMAN | Tony Booth 1 Parkside, Hensington Gate Woodstock, OX20 1UR Tel: (01993) 811642 |
| GENERAL AND MEMBERSHIP SECRETARY | John Oaker 19 Broadway North Walsall, West Midlands WS1 2QG Tel: (01922) 633042 E-mail: johnoaker@btinternet.com |
| NEW SPARES SECRETARY | John Gogay Cherry Hinton, Orchard Way Wilmington, Kent DA2 7ER Tel/Fax: (01322) 221493 |
| MAGAZINE EDITOR/ TREASURER | Phil Benson 4 Dunlin Close, Redhill, Surrey RH1 5HJ Tel: (01737) 772202 |
| RALLY SECRETARY | Howard Pryor 12 Park Road, High Barnet, Herts EN5 5SQ Tel: 0181-440 8623 |
| CLUB HISTORIAN/SECONDHAND SPARES CO-ORDINATOR/ JOINT EDITOR | Steve Coulman 23 Park Street, Messingham Scunthorpe, S. Humberside DN17 3RU Tel: (01724) 762061 E-mail: stephencoulman@globalnet.co.uk |
| ORDINARY MEMBER No. 1 | Tony Thorpe |
| No. 2 | Forbes Alexander |
| No. 3 | David Miller |
| No. 4 | Paul Norton |

*When writing to a committee member and you require a reply, please enclose a
Stamped Addressed Envelope*

*Please note that all the above committee members fulfil their positions in their spare time and not
as a full-time occupation, so when contacting them other than by letter, please ensure that
you choose a reasonable time of day*

CONTENTS

| | |
|---|---------------|
| EDITORIAL | Page 2 |
| CHAIRMAN'S REPORT | Page 3 |
| SPECIAL MEETING REPORT <i>Special Rally meeting report</i> | Pages 4 - 5 |
| TRIUMPH INTERNATIONAL | Page 17 |
| LETTERS | Pages 6 - 7 |
| THE MAROON MAYFLOWER <i>by Pat McKeefry</i> | Pages 13 - 16 |
| INTERNET | Page 10 |

The information contained within Flower Power is the view of the writers and not necessarily those of the editor or the Mayflower Owners Club. Every effort is made to ensure the accuracy of the information contained, however use of such information is entirely at the members own risk and neither the club nor any individual shall in any way be liable for injury, loss or damage resulting directly from the use of such information.



TRIUMPH MAYFLOWER CLUB SHIRTS SHORT-SLEEVED POLO & LONG-SLEEVED SWEAT SHIRTS

WITH EMBROIDERED MAYFLOWER LOGO

Available in Small, Medium, Large, Extra Large, and Extra Extra Large

Colours available:

Navy, Black, Red, Bottle Green, Emerald, Sky, White, Bright Yellow, Royal Blue, and Maroon

Prices: Polo Shirts — S/M/L £14 ExL/ExExL £15

Sweat Shirts — S/M/L £16.50—ExL/ExExL £17.50

ORDER FROM THE SPARES SECRETARY

(Cheque with order please, made payable to Triumph Mayflower Club. Add £2 per garment for P&P)

EDITORIAL

Greetings

by Steve Coulman

NOT LONG to the new millennium and a new era of Mayflower motoring in the UK - the loss of leaded fuel!

Members abroad are no doubt wondering what all the fuss is about. Lead replacement petrol (LRP) has been deemed by the petrol companies as uneconomical to apply for a British Standard and it is likely to be phased out in about 5 years or so as the old bangers go to scrap.

It is vital that once you have chosen a brand of LRP that you stick to it, and this also goes for any additive that you may decide to use in unleaded petrol.

I haven't made a firm decision yet as I've got a full tank of four star that will last me over the winter and into the spring. I think I'm going to opt for Millers in unleaded.

Next year will hopefully be a bumper year for the Club and it is the committee's fervent wish that we get at least 20 Mayflowers to the 2000 National Rally.

If you haven't attended a rally before or not attended in recent years (why?) please make every effort in 2000. You won't be disappointed.

WANTED

A LIST OF SPARE PARTS KEPT IN YOUR GARAGE/SHED

FOR THE SECONDHAND
SPARES CO-ORDINATOR TO
BUILD UP A DATABASE OF
PARTS AVAILABLE FOR
SALE/SWAP

This is to the benefit of all of us
as members with
needs/wants/sales can be
brought together

Thanks to members who have
already sent in details

*Contact Steve Coulman
details inside front cover*

To overseas members I ask that you continue to send in your letters etc., as we are a worldwide family of enthusiasts. We may have the greatest concentration of members in the UK but we value and hope for your continued enthusiasm and support for the best (probably) little car club in the world.

To all members around the world I send best wishes to you and your loved ones over the festive holidays and hope that the new millennium brings everything that you wish for - the remanufacture of over-riders and tool kits.

Chairman's report

NOW THE long winter evenings are upon us (in the UK) most of us will no doubt be taking the opportunity to correct some of the niggling faults which have appeared during the summer's motoring.

Others with major projects and overhauls in front of them will no doubt be venturing into their cold garages, hopefully completing their work for the coming of spring.

My summer motoring has been considerably curtailed due to a house move but now things have settled down I find I am able to give some attention to KSF 804.

I have an MoT coming up shortly and have been trying to correct a lack of hard brake effect on the nearside rear hub. I have suspected wear and tear in the compensating mechanism and to offset this I have adjusted the nearside brake rod length and this seems to have had the desired effect.

Hopefully I will pass the MoT test first time.

I feel there are two major items for all of us to ponder before the end of the year - one being the end of leaded four star fuel (in the UK) and how we are going to cope with our side valve engine and secondly how we can contribute to the Club plans for celebrating the year 2000.

As far as leaded four star is concerned I am sure we will all have our own individual thoughts with either the LRP (lead replacement petrol) on offer at most pumps these days or by the use of one of the many additives now on the market.

One of the advantages of Club gatherings is that members can give their opinions and impressions of the relative additives. I personally will be going for one of the original four additives recommended after the recent trials with the Metro engine (small British car with A-series engine).

I hope members are able to respond to the requests made in the minutes of the Rally 2000 planning Meeting contained in this edition.

It is hard to believe that our car has been on the road for 50 of the last 100 years - do try at least to make your presence felt at the Club Rally in June which I can assure you will be the largest gathering of Mayflowers we have ever had together.

We do need your presence for this momentous occasion.

WANTED

Your articles etc for the next Flower Power

Phil Benson will be editing the next edition and all items must be

received no later than

25th February 2000

Special Planning Meeting — Club Rally

Sunday 28th November 1999

THE CHAIRMAN opened the meeting at 2.00 pm.

Members present were: John Oaker, Peter Benson, Tony Thorpe, Phil Benson, Howard Pryor, Maurice Wilks, and Stephen Coulman.

Apologies were received from Paul Norton and John Gogay.

Peter Benfield welcomed everyone to the special planning meeting to discuss the Club Rally in 2000.

Howard told the meeting that the rally was to be on 25th June 2000 at Bletchley Park, Milton Keynes.

Combined rally

Once again it will be in conjunction with the Razor Edge, Pre-1940 and Roadster Clubs. There will be no marquee as we shall have a room in Bletchley Hall.

On the day, 10:30 to 17:00hrs, there will be a model boat endurance race, military museum, conducted tours of the Hall and Churchill museum, as well as the usual Club activities.

Cost of entry is £3.50 per Mayflower, driver and one passenger. Other rates are £4 per head and £3 per OAP.

Howard put forward the idea that a Mayflower be put on a revolving turntable as if on sale/display at the 1950 Motor Exhibition. This was well received and a general discussion took place as to how this may be safely achieved at a moderate cost.

It was agreed that John Oaker contact other clubs to see if we could loan/hire a turntable from them or another source.

Peter Benfield said he would contact Mayflower Engineering in Sheffield to see what the cost might be to have one made for the Club that may be reused.

Brochures

Stephen Coulman said he could provide advertising brochures etc to help with the display.

All members are asked to contact John Oaker if they have a suitable turntable or know where one may be obtained.

Furthermore, any member with material that they think may be of use for the display should contact Stephen Coulman.

For members who wished to make a weekend of the rally there are many competitively priced hotels etc in the area. It was hoped that members could have an evening meal again on the Saturday, cost in the region of £16. Anyone who is interested in

making it a weekend event should contact Howard as soon as possible. Peter Benfield said he and Sue would be happy to provide a cake to celebrate 25 years of TMOC.

It was agreed that the cost of all prizes to be met from Club funds in the future as the Chairman has been buying the Concours cup himself from his own resources.

Certificates

All attendees at the rally would receive a certificate of attendance as it was felt these had been well received by the membership. It was agreed that there would be the overall concours winner and a top 5 again, as last years' rally.

Phil suggested a 'Back Seat Memorabilia' competition that was well received and agreed. The idea is that for a period, say half an hour, members would 'dress' their cars up as if it had just been parked in the 1950s, eg 1952 newspaper, Motor magazine, old maps, period extras etc. The Chairman and Mrs George Jeary will judge this. Prize to be decided.

Loretta Pryor is to run the Raffle and Tombola again after last years success. Thanks were extended to Loretta. Prizes are required. Please contact Howard.

It was agreed that the Club contributes to free hot drinks (tea) on arrival and mid afternoon along with the other three Clubs.

Members are requested to contact John Gogay as soon as

possible regarding the delivery of spare parts to the rally.

Members are requested to suggested ideas for the 2001 rally, and beyond. Do you know of a venue that could accommodate about 100 cars and entertain family and friends? Contact Howard or any committee member.

Tony Thorpe wondered if anyone had considered a 'run abroad' to France, Belgium or Holland. This was well received but requires substantial planning. Would members be interested in such an event, say to the 'Amster' in Holland? Contact Howard or any committee member.

Advertise

It was felt that due to the geographical challenges that the Club faces members should advertise the rallies/events they were attending so that others could join them.

If you are going to an event that you feel other members would enjoy let the editor know so that it can be advertised in *Flower Power*.

Phil Benson has put a lot of effort into a Club Web Site for the Internet. It was agreed that this should now be handed over to a professional company so that the site could be launched.

The initial fee would be about £100 with a yearly fee of about £50. The club would control the content. Phil was thanked for his work in this area.

LETTERS**Thank you**

Dear Editor,

Many, many thanks for sending the *Flower Power* with the pictures of my Dad in (the late George Jeary - Ed). He was so proud when the Club proposed that a trophy be named after him and for two weeks after he was still over the moon.

I think everyone at the rally got the drift on how honoured my mother and I were to present my father's trophy on the 20th June. We felt like celebrities and know how dad must have felt that day.

Once again many thanks.

*Mike Jeary, 30 Burbages Lane
Longford, Coventry CV6 6AY*

(The George Jeary most original Mayflower award will be presented at the 2000 rally. The award has been in existence for two years and two different cars have won it - it could be you next! Turn up in June! - Ed)

A Flower with power!

Dear Ed,

As some of you may remember the Arkansas Mayflower began restoration some three years ago. As there is limited access to Mayflower engine parts here in the States I decided to look for

alternative power. After extensive measurements, I found an old Nissan power plant would fit the engine compartment with only minor modifications.

In addition, the transmission would also fit into the transmission doghouse. The most amazing part was that the motor and transmission fitted so well that I was able to use the transmission mounting bracket location of the Mayflower.

The Nissan I used was a floor shift. As a result, the column shift of the Mayflower was removed, and the master and slave cylinders of the Nissan shift were substituted with a bracket made and mounted under the floor next to the brake master cylinder.

The only modifications were: the steering arm had to be modified to clear the cylinder head; the motor mounts for the Nissan were reversed and brackets welded to the frame; an electric fan was fitted; the Nissan transmission drive shaft was cut and welded to the rear section of the Mayflower rear end; conversion of the Nissan speedometer shaft and housing; and the removal of the anti-smog pipes and brackets built to mount the Mayflower air cleaner.

The Mayflower now moves down the freeway at a respectable 60 to 65 mph and parts are readily available.

At two British Auto shows even the judges were fooled into

thinking the conversion was a factory original.

If the idea of a conversion appeals to you and you would like to have photographs of how the conversion looks please drop me a line and I will be happy to help.

*Leyland Felix, 310 Higdon
Hot Springs, Arkansas 71913, USA
Tel 1-501-623-9752 or
Fax 1-501-321-0849*

Convertible Mayflower for sale

Dear Ed,

It is with some regret that I have decided to sell Emma. Some of you may recall Emma being around in the early 1990s (see Spring 1990 Flowerpower) when my father, Pete Smith, owned her.

Well, they moved abroad where she was used daily until being laid

up and then being brought back to England. The hood and trim have been removed, some welding undertaken and much of the front suspension and brakes renewed. Her bodywork is generally solid but tatty and the engine drives.

Emma is a saloon converted by my father to as close as possible to the original specification and she has a fully reconditioned Herald 1300 engine with a stainless steel exhaust.

I will consider any offers from interested persons, which doesn't mean I'm after silly money as I know she is only worth (in monetary terms) what I can get for her at the time of sale. I can deliver Emma to anywhere in the UK.

*Simon Holland (859)
28 Austrey Avenue, Lenton Abbey
Nottingham NG9 2SX
Tel 0115-917 7371*



I'll give you "The laws of physics should prevent movement by a Mayflower"!

*TMOC
celebrates
Year 2000
by going
onto the
Internet*

LINCOLNSHIRE LOUTH MOTOR CLUB

Incorporating



**Lincolnshire Automobile Club
and Louth Motor Club**



Founded 1900

Britains Oldest Motor Club

MSA Recognised Club

CENTENARY CELEBRATION 1900 -- 2000 AT

NEWARK SHOWGROUND Sat 20th & Sun 21st May 2000

In Conjunction With

The Newark Advertiser

A Display of Cars & Motorcycles from

1900 to the present Day



**Sideshows - Fairground
Tradestands & Autojumble**

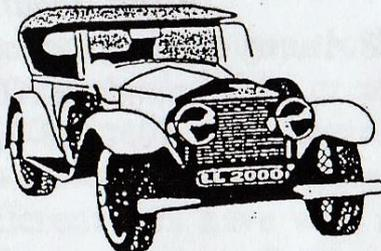

**And Other
Attractions**

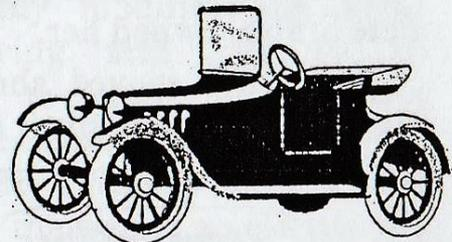

Including New Vehicle Dealers

Caravan Clubs Welcome

For further information Tel:-

John (01472) 316597 General

Ken (01472) 825457 Enquiries

Brian (01472) 317225 Cars & Motorcycles

Dave (01472) 234932 Caravan Clubs

Mick (01724) 277651 Trade & Autojumble

Lorraine (01636) 681234 New Vehicle Dealers



Trail-blazing Classic Car Show to be relaunched

THE Classic Car Show, which 19 years ago was the UK's first indoor exhibition exclusively for classics, is being relaunched by its original organiser.

To be held during next year's Easter Bank Holiday on April 23/24 at Brighton — where it was so successful during the 1980s.

The show will feature a number of halls each dedicated to

individual marques, as well as general halls, a large autojumble and trade and dealer stands.

The new format of dedicated halls will enable devotees of some of the world's most charismatic marques to see the evolution of their favourite cars over the years.

Discussions are currently taking place with all the leading clubs representing the featured marques to ensure that as many significant models as possible are on display.

The show, which will become the only car exhibition south of the Thames, is being held at the Stakis Brighton Metropole. Entrance fee will be just £6.50.

Full information is available from John Cole on 01344 642482.

1953 TRIUMPH MAYFLOWER

Grey with red seats

Body very solid, no welding done or needed

All glass removed from car and ready for respray

Engine rebored and reground and rebuilt with all new parts including valves etc. Just needs the cylinder head putting on

Bumpers and over-riders present and straight but need plating

Only parts missing are door trim panels and roof lining

Loads of historical paperwork with the car

Orinal registration number with buff log book but not on Swansea

V5 documentation yet

Asking price £600

Contact:

Ron Norman (Member 800) on 01344 622707

5 Norfolk Farm Cottages, The Great Park

Internet

SURFING THE Internet I visited the Coventry and Warwickshire Information Service site. There was a news item on the proposed monument to celebrate Standard Triumph in Coventry.

The 1.5 metre high stainless steel model of the Standard Trademark will be situated outside the Standard Social Club on Coventry Business Park, Tile Hill Lane.

The news item had quotes from officers of the TR Register, the main sponsors of the scheme, but was adorned with a photograph of a white Mayflower. Unfortunately I couldn't read the registration. Anyone know the owner?

Phil Benson is working on a Web Site for the Club and the demo version I have seen is quite impressive — perhaps not as flash as the big clubs sites but more friendly and inviting. If you have any ideas or items that you think may be of use to Phil please give him a call.

Did you know?

MAYFLOWER, TT1DL / TT5E was registered as LRW 323 on 30th October 1951.

Where is she now?

Another!

The first ever winner of the TMOC Concours competition, held at the first Club rally at

Dodington House, Chipping Sodbury on the 1st June 1975, was John Bath's Mayflower NUU 158.

Where is she now?

Do you have any photographs of the first rally to share with Flowerpower in the TMOC's Silver Jubilee Year?

Steve Darley (161)

It is with sadness that I report the death of Steve Darley. Steve was a big man in many ways, both in stature and as a person. His quiet unassuming approach was warm and friendly and his knowledge of the Mayflower, both technically and historically, was unquestionable. His car (OUM 864) is the best example I have ever seen having been the subject of a meticulous 5-year restoration. I believe that it is to go on loan to a museum soon and I will report its whereabouts when it is made known. The club sends its condolences to Steve's family.

Mayflower prototypes & convertibles

THERE WERE eight prototypes, ten coupes, and one drophead Coupe converted from the saloon body. Costs of strengthening the bodywork etc cut the production of convertibles (pardon the pun).

I have spoken to a gentleman in the UK (who wishes to remain anonymous) who claims to have one of the coupes. The engine and chassis numbers are correct as is the original colour scheme.

However, it has no registration (exported and reimported?) and I've not yet had the opportunity to view it. It could be the genuine article (I have no real reason to think otherwise) or a later conversion like Emma (see Letters).

I have finally got an answer from the DVLA (after some help from 10 Downing Street) re the existence of any registered convertibles — there are none.

However, Derek Graham of the TR Register has forwarded some information he has come across in his search for Triumph history, which will be of interest to all of us looking for an early or unique Mayflower.

Registrations of prototypes are: KDU 272, JVC 916, KRW 781, JWK 612, JVC 915, JVC 916, KWK 658, KWK 656, LRW 42.

Known registrations of coupes are: KRW 141, KRW 32, KRW 224, KRW 15, KRW 417. This suggests five were exported.

The drophead coupe — a coupe with removable side skirts — was registered as KRW 28.

Good hunting in the scrap yards, barns and lock ups in your neighbourhood!

WANTED

Engine hand crank — starting handle (or drawing with dimensions)
Carburettor gaskets (float and throttle chambers). Tool strap dimensions in engine bay. Friction collet nuts 600286-7

Cliff Veary, 687 Eglinton Ave East, Toronto, Ontario M4G 2K6, Canada
E-mail: cliff.veary@mesca.mea.com

BRAKE SHOES

Part No: 101824 — Price £9.50 per wheel

Available from the Spares Secretary

Repair of broken barrel locks

UNABLE TO find new or replacement locks for the boot and bonnet I decided to have a go at repairing the barrels myself.

This turned out to be a lot easier than I thought.

Follow these simple instructions and accompanying sketches to be safe and secure again.

However, the barrels are made of very soft 'monkey metal' so take care.

1. When new the barrel has a nib on the end that acts as a cam to

engage the lock. Nothing fancy or complicated.

2. Due to abuse or fair wear and tear the nibs break off or wear down so that the lock becomes inoperative.

3. With a soft file gently remove the remainder of the nib leaving the end of the barrel flush.

4. Drill a pilot hole at an angle into the barrel starting from where the nib has been removed. Gently insert a suitably sized self-taping screw.

5. File off the head of the screw to dimensions similar to the original. There is a certain amount of guesswork here but I got it right on both occasions (clever old me).

6. Refit the barrel and lock up your Mayflower - or should that be daughter?

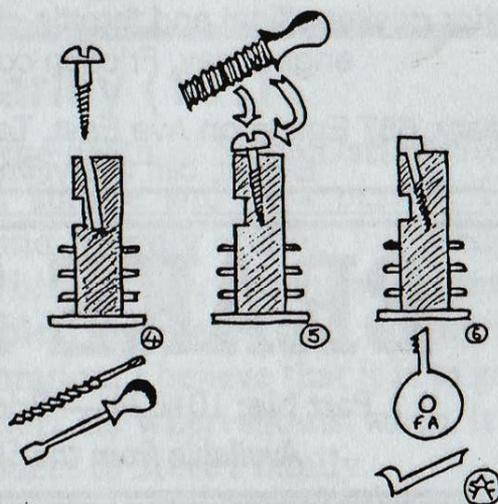
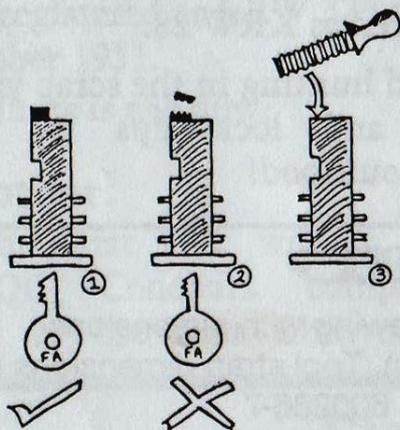

The maroon Mayflower

by Pat McKeefry

HAS ANYONE noticed the maroon Mayflower which was on show at Gardon last year (May 31 1998)?

It was last seen speeding towards Birkenhead where it is believed to have spent the night before taking an early morning ferry departure towards Dublin en-route to a little village in Northern Ireland called Randalstown.

Our Membership Secretary can confirm that a new member has enrolled from the above village and believe it or not has set about restoring an already fine car.

His name is Pat McKeefry and he decided when he was five years old that he would one day buy a Mayflower.

Pat takes up the story . . .

One June day when I was a little boy a lady arrived at our house in a beautiful new black Mayflower. My family came out to view this executive looking car.

When they had retired to the confines of the house I sneaked out again for another peep. I was exploring when I discovered that the door was not locked. I opened it and was just about to climb in when I was spotted by my sister.

I persuaded her, with a few threats etc, to be quiet and the two

of us climbed in. She was a year older but still I managed to convince her to sit in the passenger seat because in those days the ladies did not drive.

I pretended to drive and accompanied by the appropriate noises we went for an imaginary drive around the farmyard.

She was loving it but not as much as I. I felt a real grown-up. During this time we were aware of a shadow outside the window and when we looked up we saw my father accompanied by our visitor peering in at us. We were quickly removed from our dream trip and the consequences of our fantasy journey must remain a secret . . .

Since then I grew up, got married and my wife and I have four daughters — some people say lovely daughters and at times I have to agree.

Wedding

Well last year our eldest daughter announced, not unexpectedly, that she and her boyfriend had got engaged and they would be getting married in August 1999.

After the usual emotion and commotion I set to thinking about the wedding. Well, what does a man do in a house with five women when it comes to prepare for a wedding!

I enquired if she would like an old or a modern car for transport on the big day. When she said she would like a limousine or something like that my wife

suggested they should get a few prices.

I thought that was an excellent idea. When the quotation was received I seized my opportunity and suggested we could buy a car for that price.

I knew it would take a lot more but it was too good an opportunity to miss. I had a chance to fulfil my dream and I wasn't going to let it slip away. After further discussion we decided to look for a Mayflower.

Common sense

At this point common sense went out the window and I was off on a flight to Glasgow to look at a Flower. Sadly it was not for me. It fitted all the criteria. It was black, needed some work done and was driving.

On careful examination I decided that I would continue my search. It was going to involve too much work for me. I returned home disappointed. Indeed some of my project money had now been wasted.

The next day I got a phone call from a friend and neighbour who is a Triumph TR7 owner. He said that a member from the local Triumph Club had gone to Gaydon and seen this lovely Mayflower for sale.

He could not give me any details except for the seller's phone number. I rang and the car and its owner were still on their way

home. Thank God for answering machines.

I left a message and Frank rang me back when he got home. He listened to what I wanted — a black Triumph Mayflower — and then he said sorry this one won't suit, it's maroon.

He went on to explain the condition of the car, the price that according to the club it was believed to be the oldest Mayflower on the road. Being an impulsive sort of chap I said I'll have it. Frank said he would not sell it until I had seen it.

Eventually I arranged to fly over and see the car. Frank thought I was going to have a look but I just wanted to bring it home.

I flew to East Midlands airport and was met by Frank's very kind wife, Marje who brought me back to meet Frank. He, by this time had returned home from work.

Good look

I had a look at the car and liked what I saw. We packed up the spare parts and completed the necessary paperwork before sitting down to a beautiful dinner which Marje had prepared for us.

At 7.30 pm I set off for my sister's house in Birkenhead. Frank said he would travel with me for a few miles to make sure I was familiar with the gear changing.

He rode beside me for what seemed like a very long way and then said that he would join Marje

who was following behind in their car.

I soon reached Buxton and was going along fine until I took a left turn instead of a right and Frank was still behind me! He must have travelled halfway to Birkenhead behind me. Eventually the Mayflower was too fast for his modern car and he gave up trying to keep up with me!

Shortly afterwards the rain came down and I was a bit worried in case I would be flooded out or that I couldn't see where I was going. My fears were unfounded — no

wet feet and the wipers worked a treat.

I arrived in Birkenhead at 12.30 am and was greeted by a very worried looking sister. This journey takes a little longer in a Mayflower especially in torrential rain.

I was also met by my two nephews who were ready for a test run but when I showed no enthusiasm they had a good look around the car under the amber street lights and came into the house with a list of questions. I was tired more from nervous uncertainty than anything else.

Is your Mayflower colour correct?

For those of you about to embark on a costly respray or touch-up job the following should prove to be invaluable:

ICI can still make the original paint colours which are available in cellulose or two-pack — all that except Cotman Grey, but research is presently being undertaken to find the correct formula

Comet Blue, ICI 2281 — Jade Green, ICI 5398M
 Royal Maroon, ICI 3105 — Black, ICI 2007
 Cotman Grey, watch this space!

*Thanks to Humberside Paints of 1 Brumby Wood Lane
 Scunthorpe, North Lincolnshire DN17 1AA, England
 for the above information. They can mix/supply the paint to order
 Tel: 01724 841647 · Fax: 01724 281702
 Cost (Dec 99) £32.47 per litre. Approx 3 litres for a full respray*

The next morning we had an early start for the 8.00 am ferry from Liverpool to Dublin. It was a new Sea-Cat and the temporary ramp down was extremely steep.

I was in the queue behind a lovely new Mercedes and I followed down the ramp very gingerly. I need not have feared because the brakes held precisely when needed.

I parked on the car deck and found a seat on a very crowded boat. Not being a good sea traveller I can say the journey was more than choppy and I was sure my latest acquisition would be rolling about on the car deck, bashed by a lorry on one side and maybe the Mercedes on the other.

At that point I didn't care, I wanted to be on *terra firma* in Dublin docks.

Arrival

We duly arrived. Most of the passengers did not complete the journey as well as the Mayflower and me. We were safe and well.

As I drove off the boat the rain poured down again but I didn't mind. We are used to plenty of rain in Ireland.

When you are on familiar territory you feel as if you are home but I still had 140 miles to go. I set off but before long the wiper on the driver's side decided it needed a rest.

The tightening nut had worked loose but having only had limited experience of the workings of

modern wipers I did not know how to tighten it.

I drove on for the next 100 miles with no wipers! When things got really bad I hopped out at traffic lights and manually operated the blade.

Thoughts of doing damage to the mechanism rapidly disappear at a time like that.

For the last half-hour the sun came out and I felt that at last the Mayflower was getting its deserved Irish welcome. I was home at 2.30 pm having driven from Dublin in two and a half hours.

The roads are not as busy over here and the Mayflower was humming along beautifully. It was just a little troublesome with the gear-changing from first to second but I quickly developed the knack of coping with it.

I was happy to be home and am now the proud owner of a lovely maroon Mayflower. It's sad in a way that my father and the lady who came visiting are no longer around to see it.

My mother did survive to see it and was able to recall the story of how the seed of interest had been sown all those years ago.

My sincere thanks go to Frank and Marje Smith for their kindness, hospitality and honesty in helping me to become a Mayflower enthusiast.

The next 12 months of the life of ORB 639 will appear in a later edition of *Flower Power*.

Triumph International Millennium Event

TO celebrate the millennium Triumph Forum agreed to organise and support a major all Standard Triumph club event.

It has the aim of bringing together the largest gathering of owners and their cars and all the related activities of Triumph Forum in one place on the late May Bank Holiday, 28/29th May 2000.

Mallory Park (Motorsport) Ltd (MPL) have offered the site for the event provided we share the venue with events already scheduled. This includes motorcycle racing on the Sunday and car racing (including our own Triumph car race) on the Monday.

Fundamentally this will still be a traditional classic car show — a gathering of like minded Standard Triumph enthusiasts using the excuse of the millennium to come together to celebrate the future of our clubs and the cars we all support but which on this occasion will be held at a motor racing circuit.

You will be able to acquire bits and pieces at the trade stands and autjumble, to view the cars on

display, watch a parade lap on the circuit, take part in convoy runs or perhaps watch some exciting racing.

Entrance tickets will cost £7.00 for Sunday, £8.00 for Monday or a combined two-day ticket for £10.00. Camping will be free. There are limited spaces for tents and caravans and these are available on a first come first served basis.

Howard Pryor represents the TMOC at the Forum. The TMOC, along with our rally partners, are joint hosts of the next preparation meeting in early 2000 so it would show our commitment if members asked Howard to raise any matters, ideas, etc.

Let's try and get as many Mayflowers there as possible on 28th and 29th May 2000.

Mayflower
engine and gearbox for
rebuild - £50

1954 Mayflower
V5 and chassis plates
plus valuable Reg. No.
TPE 220 - £200

TELEPHONE:
01902 336271

SERVICE BULLETIN



STANDARD AND TRIUMPH VEHICLES

No. V.60G. NOT FOR PUBLICATION Date 16.7.51.

COIL TO DISTRIBUTOR H.T. CABLE
"MAYFLOWER".

Instances have occurred, where this cable has been severed by vibration, when used in conjunction with the radio suppressor. The introduction of the sparking plug lead cleat, which was fitted to prevent Nos. 1, 2 and 3 cables making metallic contact with the engine, by restricting vibration, has prevented fracture of this cable.

The cleat is shown fitted, in the illustration overleaf, its incorporation necessitating the lengthening of the three front sparking plug leads. The new length of leads are 11.7/8", 8.1/8" and 10.3/4", respectively, for Nos. 1, 2 and 3 cylinders.

When replacing this cable, following failure, the Cable Cleat, Detail No. 60527, should be installed together with the necessary longer leads. The Cable Cleat may be obtained from our Spares Department.

The Cable Locating Cleat and longer leads, were introduced in normal manufacture on Engine No. TT.7487E and future, or for finished Cars, at Commission No. TT.7413.

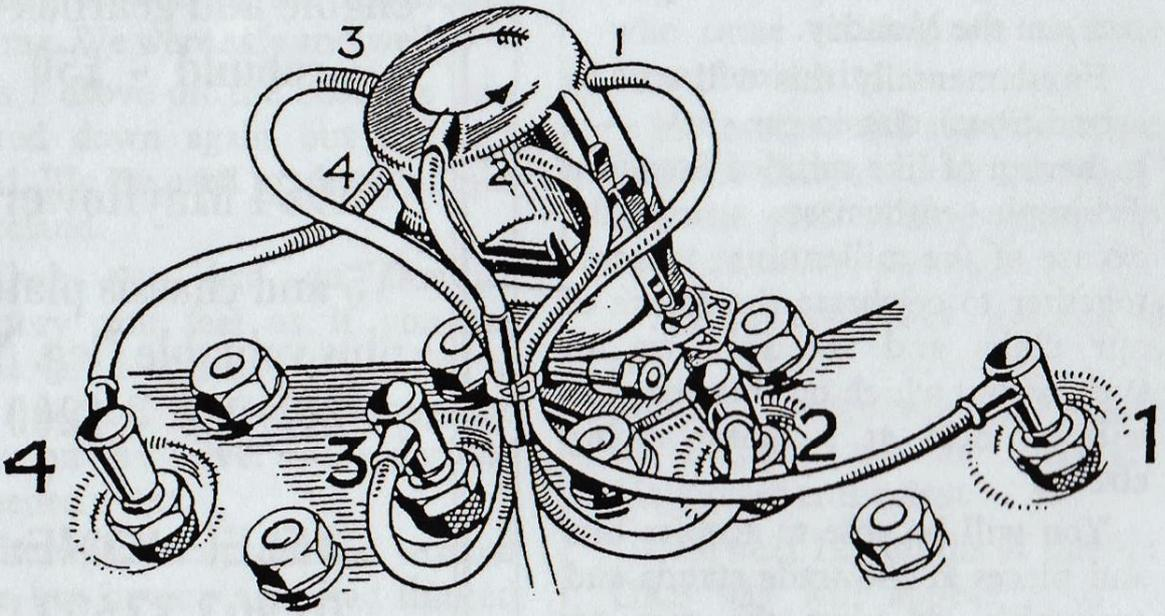

Membership and Vehicle Details

| Member No. Expiry date | Name and address | Phone Number | Commission Number | Current Car reg & condition | Date first registered | Colour now exter/intern (original) |
|---------------------------|------------------|-----------------|----------------------|-----------------------------------|--------------------------|--|
|---------------------------|------------------|-----------------|----------------------|-----------------------------------|--------------------------|--|

0 hc

2 hc

3 hc

20 3-

42 3-

60 3-

93 3-

119 3-

160 3-

172 3-

185 3-

211 3-

230 3-

262 Hc

305 3-

316 3-

359 3-

364 Hc

374 3-

399 3-

409 3-

427 3-

445 Hc

450 3-

457 3-

462 3-

We are not currently able to show these details due to data protection regulations (GDPR).

FLOWER POWER

465 3
481 3
487 3
490 3
523 3
534 3
538 3
544 3
551 3
555 3
563 3
570 3
571 3
580 3
585 3
593 3
599 3
627 3
630 3
643 3
644 3
646 3
647 3
650 3
656 3
671 3
680 3
681 3
684 3

We are not currently able to show these details due to data protection regulations (GDPR).

FLOWER POWER

689

693

695

701

703

704

708

710

711

715

716

725

743

745

746

749

750

758

767

771

775

779

781

782

784

785

787

788

789

**We are not currently able to show
these details due to data protection
regulations (GDPR).**

792
794
801
802
804
809
810
812
819
820
822
824
826
828
829
832
833
834
835
838
839
840
843
844
845
846
847
849
850

We are not currently able to show these details due to data protection regulations (GDPR).

FLOWER POWER

852 3-
853 3-
854 3-
856 3-
857 3-
859 3-
860 3-
862 3-
863 3-
864 3-
865 3-
866 3-
867 3-
868 3-
869 3-
870 3-
871 3-
872 3-
873 3-
874 3-
875 3-
876 3-
877 3-
878 3-
879 3-
880 3-
881 3-
882 3-
883 3-

We are not currently able to show these details due to data protection regulations (GDPR).

884

885

886

887

888

889

890

891

We are not currently able to show these details due to data protection regulations (GDPR).

I hope that the information on list is correct. As the secretary I could have made one or two errors. If I have please let me know. You may find it interesting just browsing through. You may find it useful for contacting a fellow member or vehicle owner who lives near you. If you could make any additions to the list about your vehicle's details please contact me.

If, for any reason, you do not want your name and/or address published in future editions of *Flower Power* please let either John Oaker, club secretary, or Phil Benson/Steve Coulman, magazine editors, know and they will adhere to your request.

If there are any other details about our cars that you would like to share with other members please let us know so that we can act on your suggestions.

P.S. — Don't forget your membership fee for next year is due in March 2000. Subscriptions are: UK £20; Overseas £20. Any members in USA or Canada who would like to pay in dollars (U.S.) should make a personal cheque payable to J. Gogay for \$33.00.

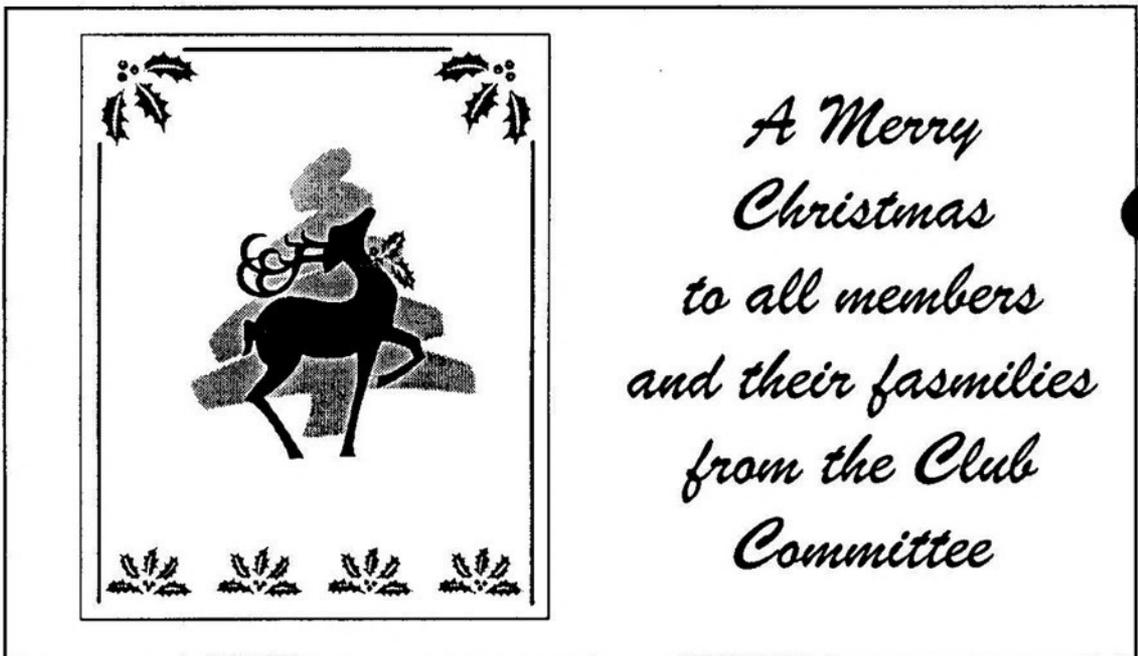

Classic Car Sills

Parts for the Triumph Mayflower



SILL £20.00

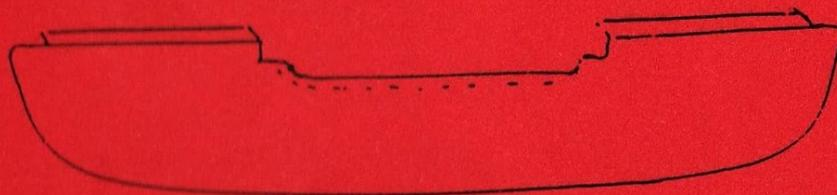

FRONT
APRON £45.00

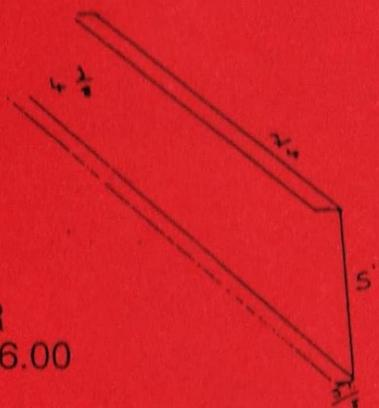

INNER
SILL £6.00

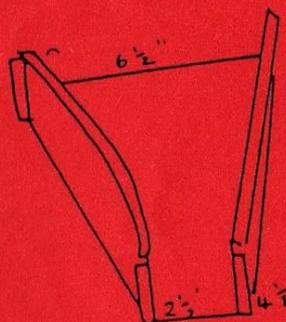

OUTRIGGER
£7.50

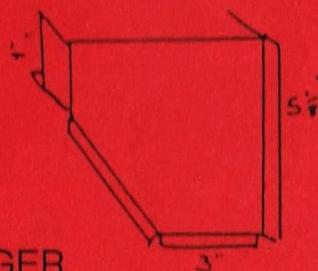

OUTRIGGER
£7.50



REAR SPRING
CHASSIS
£7.50

J. COLLIER

4 Mortimer Road, Kempston, Bedford MK42 8RE
Tel: 01234 840958 (Evenings) or 01480 477530 (Works)

