

Triumph Mayflower Club

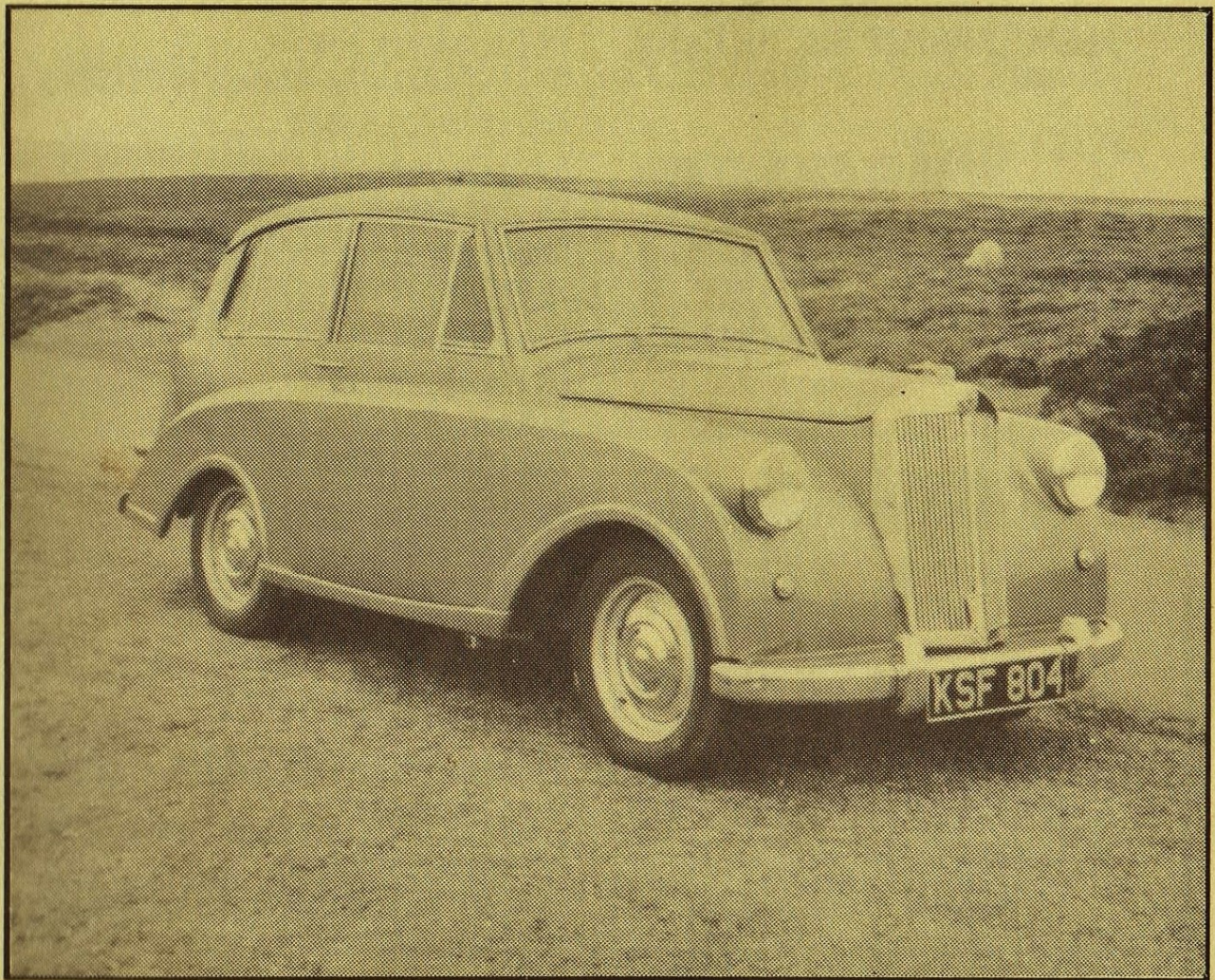

SPRING ISSUE 1995 (No. 75)

MEMBERSHIP WORLDWIDE



FLOWER POWER

THE TRIUMPH MAYFLOWER CLUB

Club Officials for 1995-96

CHAIRMAN	Tony Booth 26 Wharton Road Headington Oxford OX3 8AH Tel: (01865) 63204
VICE CHAIRMAN	Peter Benfield Low Beck, Cow Lane Middleton Tyas Richmond N. Yorks DL10 6RG
GENERAL AND MEMBERSHIP SECRETARY	John Oaker 19 Broadway North Walsall, West Midlands WS1 2QG Tel: (01922) 33042
SPARES SECRETARY	John Gogay 18 The Close, Wilmington Dartford, Kent DA2 7ES Tel/Fax: (01322) 221493
SECONDHAND	Jim Smethurst 18 Beech Grove Ashton, Preston PR2 1DX Tel: (01772) 726519
MAGAZINE EDITOR/ TREASURER	Phil Benson 4 Dunlin Close Redhill, Surrey RH1 5HJ Tel: (01737) 772202
RALLY SECRETARY	Martin Bishop 66 Keeley Lane Wooton, Beds MK43 9HS
ORDINARY MEMBER No. 1	John Oglesby
ORDINARY MEMBER No. 2	Forbes Alexander
ORDINARY MEMBER No. 3	Howard Pryor Tel: 0181-440 8623
ORDINARY MEMBER No. 4	Paul Norton

*When writing to a committee member and you require a reply, please enclose a
Stamped Addressed Envelope*

*Please note that all the above committee members fulfil their positions in their spare time and not
as a full-time occupation, so when contacting them other than by letter, please ensure that
you choose a reasonable time of day*

CONTENTS

EDITORIAL Pages 2-3

ANNUAL GENERAL MEETING Pages 4-8

LETTERS Pages 8-12

TECHNICAL HINTS INDEX Page 13

THE RESTORATION OF FCK 895 Page 14
An alternative to decorating the kitchen!

MABEL DOES HER CONCOURS Pages 15-16
From Alexandra Palace

FORTHCOMING EVENTS FOR 1995 Page 17

MEMBERSHIP LIST Pages 18-24
Why not check to see if you're up to date!

The information contained within Flower Power is the view of the writers and not necessarily those of the editor or the Mayflower Owners Club. Every effort is made to ensure the accuracy of the information contained, however use of such information is entirely at the members own risk and neither the club nor any individual shall in any way be liable for injury, loss or damage resulting directly from the use of such information.

Cover photo: Peter Benfield's car

RUST NEVER SLEEPS

Neither does MV-42™

Electronic Rust Guard

Unlike chemical rust proofing which requires special tools and uses toxic materials, MV-42 is clean, safe and easy to install. You can do it yourself in about 10 minutes. Once in place, MV-42 works around the clock, extending the life of your vehicle by helping to defend it against rust and corrosion.

Further details available from:

Kestrel Marketing

75 Bramley Avenue, Faversham, Kent ME13 8LP

Tel: 01795 532524 - Fax: 01795 590060

EDITORIAL

Well done Peter

IF YOU haven't yet seen a copy of the April issue of *Classic and Sportscar*, then I strongly recommend you beg borrow or steal a copy somehow. Perhaps even send off for a back issue to: Haymarket Reprints, P.O. Box 200, Abingdon, Oxon OX14 3FG, UK (price £3).

The reason for all the excitement? An article featuring Peter Benfield's Triumph Mayflower on a wet day's outing in the Yorkshire dales.

The article is scripted well, and the photography is superb. This must be one of the best bits of free publicity the Triumph Mayflower, and by association our Club, has ever received. Congratulations Peter on a job well done.

Divided

It seems that "Divided we conquer" is the way of the DVLA. I have received my copy of the "consultation" documents entitled "New arrangements for vehicle registration" and "Continuous Licensing".

The first paper outlines areas of difficulty in maintaining vehicle records, and requests suggestions for improvement.

To my mind it does not contain much substance, merely pointing out a few problem areas.

The only real suggestion is for "joint notification" of transfers, ie, the buyer and the seller fill in the vehicle transfer form jointly and then the seller sends it off to the DVLA. I feel this is unworkable, if a buyer turns up with cash and says "My name is John Smith . . ." the seller will hardly, if ever, ask for proof of identity. Where is this an improvement?

Moreover "The Trade", as now, appears to be considered by DVLA immune from providing timely information, . . . "The Government does not wish to impose an unnecessary burden on traders". (I wish they were as sympathetic to my views on taxation, but then I haven't the lobbying power that the motor traders have).

The second paper proposes two alternative versions of continuous licensing. Since the introduction of a new tax — based on possession of a vehicle — is the underlying principle being introduced in both cases, I shall personally write to reject them both.

If you are interested in this subject then I suggest you write or fax DVLA at Swansea for a copy of the report, read it, and then send in your comments by the 2nd June 1995 deadline, as I shall.

The address for the DVLA is: Vehicle Licensing Consultation, Alun Newport, D9/S, DVLA,

Swansea SA6 7JL. Fax No: 01792 782056.

The only way to let them know our views is to write and tell them. See you at the Annual Rally on Sunday 7th July 1995 at Broughton Castle, Near Banbury, Oxon.

Welcome

ON BEHALF of the Club, I would like to welcome Howard Pryor and Paul Norton onto the Committee. They both volunteered their services at the recent AGM, and the mood of the meeting was that as "many hands make work lighter" we should amend the constitution in order to permit two further Committee members.

This was duly done, as is recorded in the AGM minutes.

MUST PART WITH MY TRIUMPH MAYFLOWER

(MKV 225)

Any offers considered

Please contact:
Jim Berry (old member)
01227 751639

URGENTLY REQUIRED

Front Bumper for Triumph
Mayflower — with or without
over-riders

Please contact:
Steve Darley: Grange Garth
Arkondale, HQ5 0QT

Telephone 01423 364612

Howard volunteers to try to answer members technical problems and queries. (his phone number is at the front of the magazine).

Any interesting queries etc may well feature in the magazine for the benefit of other members. In addition Howard has volunteered to co-ordinate Rally attendance in the South of England by booking Club stands at Shows etc, etc.

It is hoped we can publicise details via the *Flower Power* magazine, and by Press releases to the National magazines such as *Popular Classic*, *Practical Classic* etc.

We hope that members will be able to turn up at these venues, knowing they will meet fellow enthusiasts and other members.

Paul will be assisting Howard to answer technical queries, and will also be helping Martin Bishop to organise us all at the annual rally, which takes quite some doing.

Annual General Meeting

Minutes of the Triumph Mayflower Club's Annual General Meeting held at Alumwell Junior School, Walsall on Sunday 27th March 1995

THE MEETING was opened at 14:00 by the Chairman.

Members present were Peter Benfield, Phil Benson, Martin Bishop, Tony Booth, Steve Darley, Paul Norton, John Oaker, Howard Pryor and Keith Smith.

Apologies for absence were received from Forbes Alexander, John Christison, Roger French, John Gogay, Terry Gordon and Jim Smethurst.

Phil Benson proposed that the Chairman accept the minutes of the last AGM and this was seconded by John Oaker.

Chairman's report

I would like to welcome everybody to the 1995 AGM, and a big thank you to all the members of the committee who do much more for the club than myself. The Chairman's job certainly isn't arduous, more non-existent.

I would like to thank John Oaker's school for providing the accommodation for our meeting

today, saving the club a considerable amount of money.

I would like to pass on a vote of thanks to the Triumph Razoredge Owners' Club for the choice of the 1994 Rally venue and their organisation. I hope the Club can go on from strength to strength and will increase in numbers.

I have visited several car rallies and autojumbles and have met several Mayflower owners who are not members, and there seems to be a resistance to join clubs by some people.

I think our subscriptions are good value in terms of obtaining spares, an excellent newsletter, and above all, the friendship within this club.

As I am now a full time auto-jumbler and a fully paid up member of the Autojumble Association — I bet few people even knew there was such an organisation, I certainly didn't until a few weeks ago — I will always be on the look-out for spares for the club.

I am sure this years rally will be as good as last years so I hope to see you all there.

Membership Secretary's report

This is my second Secretary's report. Again an interesting year, with lots of post and phone calls — recent post has been mainly the renewal of subscriptions. Thanks to all who have done so, and a little

reminder to anyone who hasn't quite got round to renewing yet (see page 00 to see how you stand).

When I inherited this job two years ago there were 147 members and we showed an increase last year to 148 and this year we are up again to 151. Of last year's 148 members at 31-3-94, 118 rejoined — 3 former members have rejoined and we have 30 new members. This actually gives us a very similar trend to last year.

The books show that we have 151 members today — 124 UK and Ireland, 13 USA and Canada, 4 Australia and New Zealand, 8 Europe, 1 Africa and 1 in Malaysia.

There have been a lot of letters recently — since the article in *Classic Car & Sportscar* magazine three weeks ago showing Peter Benfield's Mayflower. The main point from these letters are requests from potential buyer's! They all wanted good runners though. Watch this space.

The reaction to this article, and the one in *Practical Classics* last year prove that we need to get Mayflower's featured in as many Car magazines as possible to increase general awareness of the model.

Talking of models — the 1/43 scale models eventually came good we had some problems at source, and the back of the model was a little disappointing — but members who have contacted me have been pleased — particularly looking at the front of their model.

Finally may I urge all members to 'pester' the national magazines with details and photographs of their cars, restorations etc.

Treasurer's report

The Club accounts are now in a healthy state following a few years in which membership had declined. We now seem to be in a stable situation, from which the club can go forward optimistically.

The main account has been boosted by several factors: the sale of Mike Webber's car which was donated to the club; the profit from sales of Mayflower models; the additional revenue from the increase in subscriptions; the sale of back issues of *Flower Power*.

Because of timing, we have only had to pay for three magazines in this financial year, although four have been produced. Even so the main account balance is very healthy.

The Club Spares accounts are also in good health. There is a balance of approximately £450.00 in the second hand spares account and of approximately £3,500 in the Spares Secretary's account. This allows us to continue to have many items such as cylinder head gaskets, valve guides, valves and engine studs manufactured for supply to members of the Club.

I therefore recommend to the meeting that subscription levels are unchanged. This was seconded by Tony Booth and was

unanimously accepted by the meeting.

Spares Secretary's report

First of all may I send my apologies for not being with you all this afternoon. I believe it's only the third AGM I've missed in 16 years!

I had the offer of going to France for the weekend with the Rover Club, taking my Mayflower (hope she makes it!) which I thought might generate a news-worthy item for the club. I just hope the weather is kind to us.

As for the Spares, sales continue to be steady at around the £4,500 mark. Finding replacement parts is continuing to be more difficult but I should like to record my thanks to Howard Pryor in his efforts to help the club in locating and purchasing parts (if only we had more members with the same dedication).

Secondhand Spares Secretary's report

The main event of the year was the gift of a large quantity of parts to the club from a former member who no longer has a Mayflower and wanted a clear-out. Terry Gordon and myself went to collect them. The largest items were two doors and a gearbox, and these have now made their way to Belgium with the assistance of Peter Benfield.

Sales have been steady and I have been able to supply about half of the requests made. The account balance is healthy and I am happy to continue in the post for another year. I hope to see you all at the rally in July.

Election of Officers

As all the officers indicated a willingness to be re-elected, and as members at the meeting indicated they were willing to provide assistance to the Club, a brief discussion of the constitution was held.

It was subsequently proposed by John Oaker that the constitution be amended to allow four ordinary committee members, an increase of two over previous years. This was seconded by Martin Bishop and was passed unanimously by the meeting.

Following this Tony Booth proposed that Howard Pryor and Paul Norton be offered the new positions. This was seconded by Phil Benson and they were duly elected to the posts unopposed.

Details of the committee members will be revised in the next magazine.

Any Other Business

Howard Pryor proposed that the club spend funds on a banner and an awning for use when we take up 'Club stands' at shows in order to promote the Clubs identity. This was seconded by Martin Bishop

and Howard was duly nominated to investigate these areas on the Club's behalf.

Phil Benson gave details of the costs expended by TROC on the 1994 rally. The meeting felt that given we were now truly holding a joint rally, and not just a few Mayflower's tagging along as was the case seven to ten years ago, the Mayflower Club now deserved to be better consulted by TROC than in the past.

Whilst appreciating that the venues for 1995 and 1996 were already booked, the 'theme', and the previous nights dinner format etc, were of interest to our membership.

Martin Bishop was therefore requested to write to his

counterpart at TROC requesting that the rally becomes a topic for discussion between the clubs for the future.

The meeting discussed the availability of spares. The perennial topic of rear quarter-light rubbers was once again mooted. Phil Benson is to explore the possibility of having these manufactured, and will report back to the Committee at the rally.

Club Awards

It was decided to postpone any discussion until the next meeting of the committee to be held at 12 noon at the rally in July.

TRIUMPH RENOVN

1949 - 2 Litre

A full restoration project which has been quietly rotting away for the last 20 years. Ash frame gone, but the body panels are OK. Just about everything is there but in varying condition (at least she still looks like a car).

BEST OFFER TO:

Charles Bethesdale
120 Jubilee Road,
Waterlooville, Hants PO7 7RG
Telephone: Portsmouth
648007

ARTICLES REQUIRED FOR FLOWER POWER

Please write
to the Editor
with your stories on rallies,
restortions or anything you
feel may be of interest to
other members.

Remember it's your club
and magazine, help to
make it even better!

FLOWER POWER

Genral Account 1994/5

<i>1993/4</i>	<i>Receipts</i>	<i>1994/5</i>	<i>1993/4</i>	<i>Payments</i>	<i>1994/5</i>
894.59	Bank balance b/f	926.66	1450.00	Flower Power	1140.00
8.82	Cash balance b/f	24.75	99.25	AGM	27.00
1898.72	Subscriptions etc	2256.14	198.00	Officers expenses	140.47
45.90	Interest	39.59	20.00	Spares loan refunds	10.00
18.00	Bank number service	33.00	108.27	Rally expenses	161.50
0.00	Sale M. Webber's car	220.00	30.00	Subs FHBVC	35.00
609.91	Models	645.00	28.65	Bank charges	0.00
			458.44	Models	489.21
			111.92	Recovery M. Webber's car	0.00
			20.00	Travel expenses	0.00
			951.41	Balance	2141.96
3475.94	Total income	4145.14	3475.94	Total expenditure	4145.14

	<i>Bank</i>	<i>Cash</i>	<i>Total</i>
Opening balance	926.66	24.75	951.41
Receipts	3187.73	6.00	3193.73
Payments	1986.44	16.74	2003.18
Closing balance	2127.95	14.01	2141.96

Spares Account

<i>Income</i>		<i>Expenditure</i>	
Sale of Spares and Shirts	4475.11	Purchase of Spares	2741.96
Bank interest	54.00	Refund	10.00
		Stationery and packing materials	81.40
		Postage	500.00
		Rent	260.00
		Shirts	379.95
		Practical Classics subsscrip.	28.60
		Excess of income	527.20
	<hr/>		<hr/>
	4529.11		4529.11
	<hr/>		<hr/>
	Bank Balance		
Current account	1211.35	Deposit account	2371.38

LETTERS

Please help!

Dear Phil,

If anyone is going to an autojumble, can they look out for

rubber grommets as per the drawing below. I have tried to obtain them from the Club, to no avail. The grommet is for the carburetor/air filter joint.

I'm also looking for a good old Smiths Vacuum Gauge kit, (which must be complete). Has anyone got one tucked away?

Forbes Alexander
Member 650, Tel: 0131- 662 0693

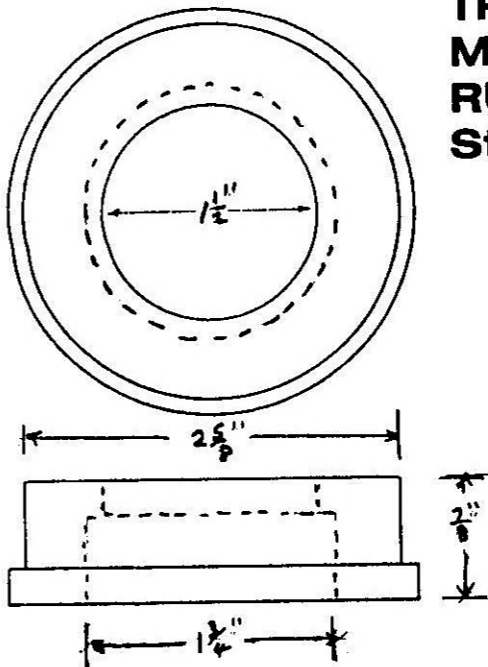

**TRIUMPH
MAYFLOWER
RUBBER GROMMET**
Stanpart No: 101784

VALVE GUIDES

Part No: 100862
Made from bronze
Price: £3.50 each

VALVE SPRINGS

Part No: 47757
Price: £2.20 each

Available from
Spares Secretary

SECONDHAND SPARES FOR SALE

Bonnet, Windscreen,
Gearbox, Headlamps, Coil,
Distributor, etc

Fair price
only wanted

Mr A. Ricketts
19 Elmer Road
Catford, London SE6 2HA

NICE SOLID RESTORATION PROJECT

1953 TRIUMPH MAYFLOWER

Complete and running

Enquiries to:

0181-440 8623

LETTERS**A deal !!**

Dear Phil,

"Free to good home" it read in the winter issue of *Flower Power*.

I was on the phone at once — 10.45 pm, who cares, can't miss a free Mayflower.

A Mr Dickinson was awake. "It wasn't his," he said, "it was nobody's (he thinks)".

He said he was a signalman for British Rail working between Ampthill tunnel and Flitwick.

He had spotted the Mayflower along the side of the track. He said if I could meet him sometime he would take me to it. So I said that I would give him a ring when I was able to make it. But the next week I was working only a couple of miles away from the area so in my lunch break (a long one) I started looking.

Yes, I found it after traipsing over lots of fields. It was behind a builder's yard. So I went back and found my way there by road. A Mr Robinson caught me looking at it.

"Do you want to buy it?" he said, "It's my daughter's. She's been wanting to sell it for years. The sonner the better, it's in my b..... way."

But it was a pile of rust, no windows, no interior, doors hanging off, but an engine all there, also not seized. So I offered him £20 for the engine. "A deal,"

he said. So not free, but a cheap engine. *OR* so I thought!

I went to pick up the engine two or three weeks later, only to find that somebody else had offered £50 for it just the previous weekend, and had taken it away. I was not amused. "Somebody in the club." He thinks! I would like to know who!!!

Martin Bishop, Member 643

On the road

Dear Sir,

Please accept my apologies for not being able to attend the AGM, due to a family gathering the same weekend.

Sincere thanks to John Oaker for all his help in obtaining a registration document (V5) and the original registration MYM 359 — the Mayflower will be on the road mid April and is at present being prepared for a respray.

However I am looking for four presentable hub caps, four overriders and also two "Mayflower" door badges. If any members can help in this direction it will be greatly appreciated to complete my pride and joy, and get us on the road.

J. Christison, Member 769
2 Daw Lane, Bentley
Doncaster, S. Yorks DN5 0PF

[Hub caps and door badges available from the Spares Secretary — Ed]

Have a break

Dear Mr Oaker,

I enclose my annual renewal cheque for £15. It would be lovely if some of the Club members came over to some of our rallies in Northern Ireland. I could arrange Bed & Breakfast accomodation or Hotels etc, cheap or expensive as preferred.

Do any members feel like organising a trip? If so please give me a ring. Tel: 01232 424981.

Charles Maginnes
3 Ardmore Terrace, Holywood
CoDown, N. Ireland BT18 9BH

And a post card

Dear Sir,

In reference to an article in *Classic and Sportscar* magazine — April 1995 — I would like to know if left-hand-drive Mayflowers in good state are on the market and if so, how to locate one as I am very interested in this make. Looking forward to hearing from you I remain with best regards,

Gil Schneider, Postfach 566
CH-8802, Kilchberg, Switzerland

It would be quite an interesting exercise to convert a RHD to a LHD, and quite straight forward I think — Ed.

Thank you

On behalf of all members of the Club, I would like to thank Mr J Wilson (Member 720) of Barnsley who donated a large quantity of surplus second hand spares to the Club. These were collected by Jim Smethurst and Terry Gordon.

See AGM minutes for further details. Ed.

Takeaway

Dear Phil,

Some time ago, you published a photograph of a rather soggy Mayflower owner standing with his umbrella held aloft in front of a pub called the Mayflower in Plymouth and you asked members to scour the world for other establishments of the same name.

You may therefore appreciate my providing you with the photograph of a Chinese takeaway espied in Faringdon in west Oxfordshire which, in its most recent incarnation, has also adopted the hallowed name!

Christopher Naish, Member 647

[I know of a Chinese restaurant in Long Crendon, Bucks, not far from Oxfordshire, also called the Mayflower. My photograph of it did not come out well enough to print, but in the words of Arnie S. "I'll be back" — Ed.]

Congratulations

To the new magazine *Triumph World* which featured a photograph of the three Triumph Mayflowers belonging to Howard Pryor (NLO 739), Bob Collins (FJA 953) and Phil Benson (JBD 807) who met up at the Grand London Autojumble held at Kempton Park Racecourse in September 1994.

**TRIUMPH
MAYFLOWER CLUB
NORTHERN
"GET TOGETHER"**

Doncaster

**Telephone:
01234 857540**



Christopher Naish's picture of the Chinese takeaway

The magazine has lots of interest to all Triumph lovers, but does seem to lean to the sports cars a bit.

It is also a bit expensive at £2.95 — Keep up the quality — Bring down the price! Ed.

**FRONT
AND REAR
BUMPER BOLTS**

Available soon
from the Spares Secretary

FLOWER POWER Nos. 70-73 (1994)

General Index

<i>No.</i>	<i>Date</i>	<i>Editor</i>
70	Winter 1994	Phil Benson
71	Spring 1994	Phil Benson
72	Summer 1994	Phil Benson
73	Autumn 1994	Phil Benson

Each item can be found by reference to the code at the end of the line, eg 70-1 means that it is in Flower Power No. 70, page 1. Where an item runs to more than one page the code takes the form 70-1/2 as necessary.

Body

New Body Parts (apron/sills/chassis mounts etc) 70-17/8 & 71-14
 Replacing those Window Strips 70-21/22

Electrical

Spark Plug equivalent 70-20

Front Suspension and Steering

Steering Idler Box adjustment 70-20

Rear Suspension and Axle

Rear Shock Absorber equivalent 70-20

General interest

Fuel Worries for Classic Car Owners 70-7/8
 Molly goes Racing to Nurburgring 71-15/16/17
 Sunday 12th June 1994 — It Was Me! 73-6/7/8
 Which Oil for Your Classic? 73-15/16/17/18
 Where have all the Flowers gone? 73-19/20

Individual restorations

Christopher Naish (647) CSN 107 70-13/14/15
 Sarah Sanders (534) 71-18/19

1994 AGM

Minutes 72-4/5/6/7/8

The restoration of FCK 895 - Part 1

by Jim Smethurst, Secondhand Spares Secretary

OUR COMET BLUE Mayflower, FCK 895 came into our family when my father-in-law, Fred, bought it from its first owner in 1969. My wife Jennifer has fond memories of "posing" in the car as a teenager, and hopes to do so again in the not too distant future!

In the summer of 1977, FCK was consigned to Fred's garage and replaced by a younger car. There she stayed until 1988, when Fred decided to sell her to my brother-in-law, Dave, who was keen to get her going again.

Firstly, Dave took out the engine and gearbox. Stripping down the engine revealed seized piston rings and the reason why the engine wouldn't run. Sadly, Dave's enthusiasm left him and I was "forced" to buy FCK in March

1990, consigning her to my garage until I had time to do something about her.

Well, five years, many jobs around the house and a new garage later, I have actually started doing something. Previous to that, all I had done was remove the rubber matting and free off the seized handbrake lever!

So far I have spent quite a bit of time underneath the car exploring! A great deal of muck has been dislodged and the sills on both sides found to be in need of replacement. Hello Mr. Collier!

The front bumper and apron are off the car and I am working on the offside chassis member, at the front by the horn bracket, where some new metal will have to be inserted. To that end I have been practising with my small gas welding set. I hope to acquire "the knack", and things are looking promising as I have stuck pieces of metal together on the workbench. However welding underneath the car could be quite different I expect! Not to worry though, I'm enjoying myself.

That's about it for now. More to report on I hope in the summer issue of the magazine, although I still haven't finished the kitchen I started in 1987!

TRIUMPH MAYFLOWER CLUB CAR BADGE

£9.00

Available from the Spares Secretary

“Mabel” does her conours! at the Ally Pally

by Howard Pryor

“MABEL” WAS invited by the Triumph Roadster Club to appear on their stand at the London Classic Car Show at Alexandria Palace for one of the first shows of the season. Held on Saturday and Sunday the 18th and 19th March, the show was organised by Greenwood Exhibitions.

Loads of hard work went into the show stand for about four

weeks prior to the day. The theme was to be a 1950s picnic.

Part of my job was to organise the painting of the scenery to go at the back of the stand. It was finished the day before the show and unfortunately came out looking more like the Swiss Alps than the English countryside it was meant to be, but that’s yet another story. Anyway this was our first indoor two-day show and nothing was going to spoil it.

Saturday was the Concours judging day, and at 6 pm the tannoy announced which Club stands should attend the Prize giving ceremony.

We were one of the stands named. All three of the cars on the stand had previously won club or show concours at some time, but as this was the Roadster stand, I expected it to be a Roadster winning a prize, not “Mabel”.

One of the Roadsters had been caught up in the storms of Friday so had a dirty bottom, the other

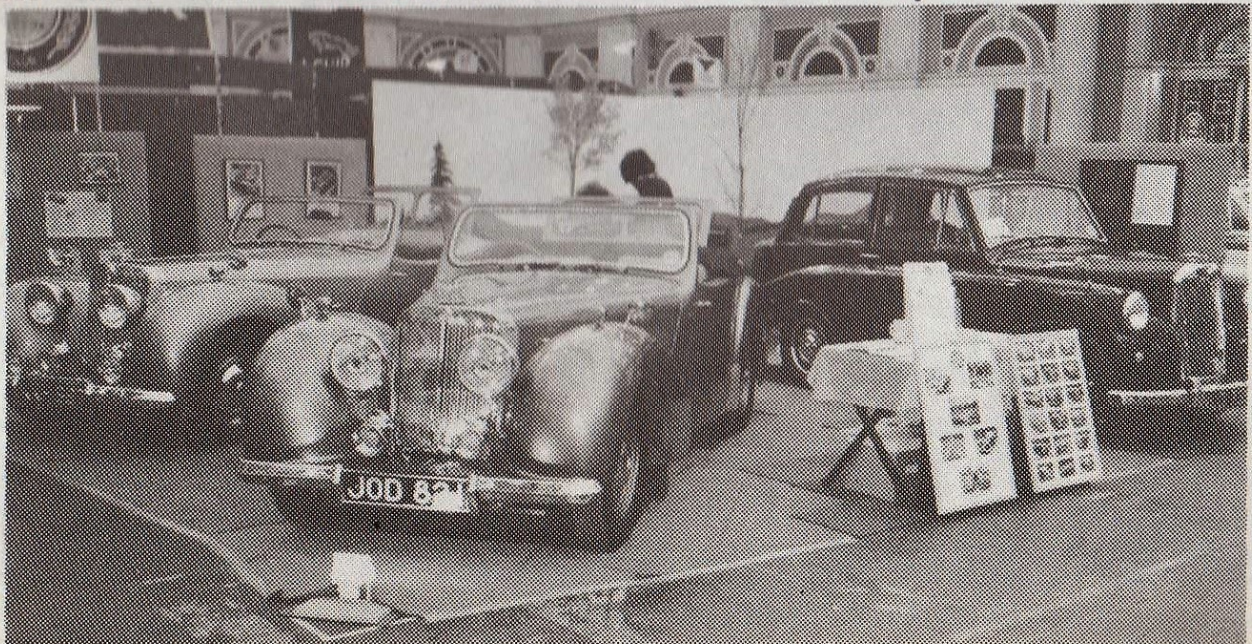

one won Runner Up in the Sports and Convertible Section to which I applauded very loudly and I thought that was it, but then came the Pre 60s Saloon section and the man was muttering something about, how you don't see these anymore and how nice it is and what a super little car and then "The Runner Up is the Mayflower on the Triumph Roadster Club stand".

Well knock me down with a feather, I was chuffed then and still am and I will say this to all you who own Mayflowers, we have one of the best loved little cars that ever was, judging by the attention that "Mabel" received at that show — "Blimey, I haven't seen one of these

for ages" was the cry every few minutes or so.

So for all you out there, don't think it! Do it! Promise yourself to get your car on the road this year, you will be amazed at the interest in Mayflowers and the fun you will get at these shows.

My season has started great. We are at the Enfield Pageant at the May Bank Holiday weekend (27th-29th) If you wish to join me, phone 0181-440 8623 anytime. If not I'll see you at the Annual Rally in July.

PS. Very well done to Peter Benfield on the article in *Classic Car and Spotscar* magazine. In my opinion it is one of the best articles on Mayflowers ever written.



Howard with "Mabel" not looking at all soggy this time!!

FORTHCOMING EVENTS

Time and Space do not permit me to publish as large a list of events as last year. However here are some of the ones where you could well see Mayflowers in attendance. Follow our advice — book in to a few of these yourself, and have a great time.

APRIL

29/30	Southern Counties Historic Vehicles 'starter' rally - Gatwick	01737 761800
29/30	Bristol Classic Car Show	01272 701370
30	Windy Harbour Rally, Blackpool	01253 393638

MAY

6/7	Goosedale Extravaganza & Rally — Nottingham	01159 289149
8	Vintage Vehicle Rally — Chatham Dockyard	Doug Barrow 01634 727777 extn 2009
8	Classic Car Rally — Leeds Industrial Museum	0113-263 7861
13/14	Borde Hill Steam Rally — Haywards Heath	01243 641284
21	Leicester Mercury Pageant	01246 239264
27/28/29	Pageant of Motoring — Enfield	0181-367 1898

JUNE

11	London to Brighton Classic Car Run — Greenwoods	01296 631181
17/18	Parham Steam Rally Sussex	Info from Old Mill SteamFairs 17 Old Mill Sq, Storrington, W. Sussex RH20 4NQ
17	Classic Car Show, Ramsbottom, Lancs	0161-792 0951
24/25	Goodwood Festival of Speed — Goodwood House	01243 774107

JULY

9	Triumph Mayflower Club Annual Rally — Broughton Castle, Banbury, Oxon	
15/16	Ardingly Rally — South of England Showground	01273 306817
16	Uxbridge Autoshow — Uxbridge Middx	0895 230421
16	Classic Car Roadshow, Elvaston Castle, Derby	01442 826371
29/30	Bluebell Railway Rally, Horstead Keynes Station, Sussex	
29/30	Cumbria Steam Gathering, Cark Airfield	01524 271584

AUGUST

5/6	Redhill Steam Rally, Redhill, Sussex	01293 773834
12/13	Rudgwick Steam & Country Show	Terry Hand — 01403 822378
12/13	Yeovil Festival of Transport, Yeovil, Somerset	01935 22319
19/20	Wolverhampton Festival of Transport	0121-5023713
27/28	Classic Car Roadshow, Wythenshaw, South Manchester	01442 826371

SEPTEMBER

9/10	Strood Steam Rally, Rochester Kent	Ken Tappenden — 01634 727777
9/10	Beaulieu Autojumble, Hants	0590 612445
10	Triumph Mayflower Club, Northern 'Get Together' — Doncaster	01234 857540
17	York Racecourse Vehicle Rally, York	0904 702108

FOR SALE 1953 TRIUMPH MAYFLOWER

NLM 888 — Dry stored for 30 years. Unrestored original condition. New clutch and exhaust. Black with red upholstery

£850 ono

Mr C. Terry, 14 The Causeway, East Hanney, Wantage, Oxon OX12 0SN
Telephone: 01235 868530

Membership and Vehicle Details

<i>Member No. Expiry Date</i>	<i>Name and Address</i>	<i>Commission Number</i>	<i>Current Car Reg & Condition</i>	<i>Date first Registered</i>	<i>Colour now Exter/Intern (Original)</i>
0 hon					
2 hon					
3 hon					
20 3-95					wn
42 3-95					
119 3-95					
121 3-95					
138 3-95					
143 3-95					
147 3-95					
160 3-95					
161 3-96					
172 3-95					
185 3-95					
211 3-95)/brown
230 3-95					
248 3-95					
262 Hon.					
316 3-95					
330 3-94					
359 3-95					
364 Hon.					
373 3-95					
399 3-95					
407 3-95					

FLOWER POWER

409 3-95

422 3-95

427 3-95

437 3-95

439 3-95

445 Hon

462 3-95

465 3-95

481 3-95

487 3-95

490 3-95

497 3-9

507 3-95

523 3-95

524 3-95

525 3-9

527 3-9

534 3-9

538 3-9

539 3-9

541 3-9

543 3-9

544 3-9

549 3-8

551 3-9

553 3-8

556 3-9

563 3-9

FLOWER POWER

567 3-9

568 3-9

570 3-9

571 3-9

572 3-9

575 3-9

580 3-9

583 3-9

585 3-9

593 3-9

599 3-9

617 3-9

619 3-9

623 3-9

627 3-9

628 3-9

630 3-9

633 3-9

640 3-9

643 3-9

644 3-9

646 3-9

647 3-9

649 3-9

650 3-9

651 3-9

654 3-9

655 3-9

FLOWER POWER

656 3-9

664 3-9

668 3-9

669 3-9

670 3-9

671 3-9

672 3-9

674 3-9

679 3-9

681 3-9

682 3-9

683 3-9

684 3-9

686 3-9

689 3-9

691 3-9

692 3-9

693 3-9

695 3-9

697 3-9

698 3-9

701 3-9

702 3-9

703 3-9

704 3-9

705 3-9

706 3-9

708 3-9

FLOWER POWER

710 3-9
711 3-9
712 3-9
713 3-9
715 3-9
716 3-9
717 3-9
718 3-9
719 3-9
720 3-9
721 3-9
722 3-9
723 3-9
724 3-9
725 3-9
726 3-9
727 3-9
728 3-9
729 3-9
730 3-9
731 3-9
732 3-9
733 3-9
734 3-9
735 3-9
736 3-9
737 3-9
738 3-9

m

FLOWER POWER

739 3-9

740 3-9

741 3-9

742 3-9

743 3-9

744 3-9

745 3-9

746 3-9

747 3-9

748 3-9

749 3-9

750 3-9

751 3-9

752 3-9

753 3-9

754 3-9

755 3-9

756 3-9

757 3-9

758 3-9

759 3-9

760 3-9

761 3-9

762 3-9

763 3-9

764 3-9

765 3-9

766 3-9

FLOWER POWER

767 3-
768 3-
769 3-
770 3-
771 3-
772 3-
773 3-
774
775 3-
776 3-
777 3-
778 3-
779 3-
780 3-
781 3-
782 3-

I hope that the information on list is correct. As the secretary I could have made one or two errors. If I have please let me know. You may find it interesting just browsing through. You may find it useful for contacting a fellow member or vehicle owner who lives near you. If you could make any additions to the list about your vehicle's details please contact me.

If, for any reason, you do not want your name and/or address published in future editions of *Flower Power* please let either John Oaker, club secretary, or Phil Benson, magazine editor, know and they will adhere to your request.

I am hoping to catagorise the condition of our cars under the following headings: = spares car; = under restoration; = runs unrestored; = runs restored (I have already started with my own vehicles and with a bit of help I am sure I could complete the task). This list will be updated and published as space permits in future editions of *Flower Power*.

If there are any other details about our cars that you would like to share with other members please let us know so that we can act on your suggestions.

P.S. — May this list also be a reminder to those of us who have not yet paid our 1995-96 membership subscriptions which were due on April 1st (members in ***bold italic*** type owe two years subs; those in *italic* have paid). Please note that members who are not fully subscribed as of July 31st will not receive any further issues of *Flower Power* or be entitled to purchase spare parts. Subscriptions are: UK £15; Overseas £21. Any members in USA or Canada who would like to pay in dollars (U.S.) should make a personal cheque payable to J. Gogay for \$35.

**Sunday
JULY 16**

**SHOW
SCHEDULE**

Show open 10 a.m. to 5.30 p.m.
Official Prize-giving 4 p.m.

Entries are welcomed in the following classes:

- | | | |
|-----------------------|--------------|-----------------------|
| 1 Veteran | up to 1919 | 10 Classic American |
| 2 Vintage | 1919 to 1930 | 11 Custom Cars |
| 3 Pre-war | 1931 to 1939 | 12 Kit Cars |
| 4 Post-war | 1945 to 1959 | 13 Replicas |
| 5 Post-war | 1960 to 1969 | 14 Military Vehicles |
| 6 Post-war | 1970 onward | 15 Master-Class |
| 7 Fire Engines | | 16 Spectators' Choice |
| 8 Motorcycles | | 17 Best Club Stand |
| 9 Commercial Vehicles | | 18 Best Trade Stand |

**UXBRIDGE
Auto
SHOW**



'CAR OF THE SHOW' Cup

Cups and Certificates of Commendation are awarded in each class.

During the day vehicles entered in the Concours sections of Classes 1 to 15 will be judged on condition and originality. Vehicles on Club Stands will not be judged individually. Club entrants who wish their vehicles to be judged should enter the Concours section of the appropriate class and may move to their club stand after judging.

Club enclosures are available for any number of cars required.

**CAR PARADES · THE 'CAR AND COSTUME' COMPETITION
AUTOJUMBLE · TRADE STANDS · REFRESHMENTS · ARENA EVENTS
CRAFT and ANTIQUES FAIRS · CHILDREN'S ENTERTAINMENTS**

MIDDLESEX SHOWGROUND · PARK ROAD · UXBRIDGE off A40

PRESENTED BY THE ROTARY CLUB OF UXBRIDGE

Entry forms from Richard Hansom, 19 Queen's Road, Uxbridge UB8 2NN
Telephone: 01895 234513

YOU NEED LODGE

for

More M.P.G.



Better acceleration



Easier starting

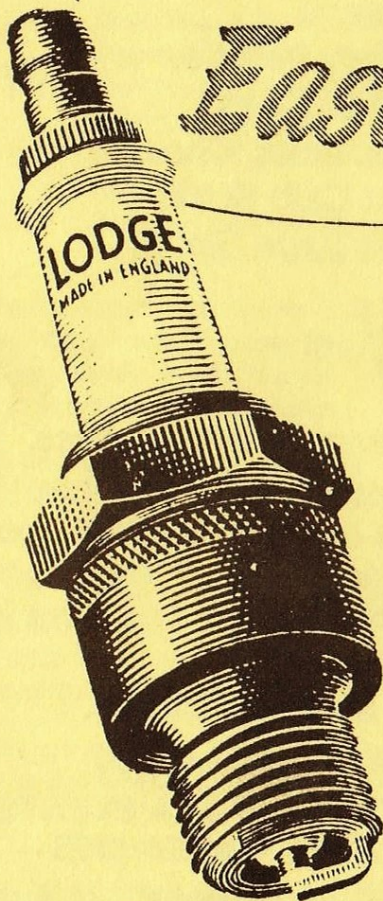

FIT

LODGE

**SPARK PLUGS
in your Triumph car**

TRIUMPH

2000
Herald 1200, 1250
Herald & Herald "S"
TR2, TR3, TR4
1800 (18T, 18TR)
2000 (20ST, 20STA, Renown)
Mayflower (12T)

	Gap size
HLNY	.025"
CNY	.025"
HLN	.025"
CNY	.025"
CN	.025"
CN	.025"
CLNH	.025"