

55

# TRIUMPH MAYFLOWER CLUB

WINTER ISSUE 1990 1989.



(MEMBERSHIP) WORLD WIDE



# FLOWER POWER



# THE TRIUMPH MAYFLOWER CLUB

## Club Officials for 1989-90

<i>CHAIRMAN &amp; CLUB SECRETARY</i>	Terry Gordon 12 Manor Close Houghton, Preston Lancashire PR5 0EN Tel: (0254) 853469
<i>VICE CHAIRMAN &amp; RALLY SECRETARY</i>	John Oglesby 33 Wroot Road Finningley Doncaster DN9 3DN
<i>TREASURER</i>	Mike Webber 31 Phillips Avenue Exmouth, Devon EX8 3HZ
<i>SPARES SECRETARY</i>	John Gogay 18 The Close, Wilmington Dartford, Kent DA2 7ES Tel: (0322) 221493 after 7 pm
<i>SECONDHAND SPARES SECRETARY</i>	Stephen Parnell Stag Cottage, Wooton Courtney, Nr Minehead Somerset TA24 8RH Tel: (0643) 84253 after 7 pm
<i>MAGAZINE EDITOR &amp; ARCHIVIST</i>	Mike Hurst 39a Littleworth, Wing Leighton Buzzard Bedfordshire LU7 0JX
<i>ORDINARY MEMBER No 1</i>	Tony Booth 26 Wharton Road Headington, Oxford OX3 8AH
<i>ORDINARY MEMBER No 2</i>	Edith Webber 31 Phillips Avenue Exmouth, Devon EX8 3HZ
<i>ORDINARY MEMBER No 3</i>	Reg Varney 32 Mackie Road Filton, Bristol, Avon

---

*When writing to a committee member and you require a reply, please enclose a  
Stamped Addressed Envelope*

*Please note that all the above committee members fulfil their posts in their spare time and not  
as a full-time occupation, so when contacting them other than by letter, please ensure that you  
choose a reasonable time of day*



# FLOWERPOWER

SPRING EDITION 1990

## CONTENTS

EDITORIAL

CHAIRMANS COMMENTS

DVLC UPDATE

LETTERS

BODY SHOP

TECH-TIPS

SALES / WANTS

## COVER STORY

This issue features a photograph sent to us from Paul Norton (462) which appeared in library book on Australia.

I suppose that we could say that even in death the Mayflower still comes out on top.

## ISSUES

SPRING.      SUMMER.      AUTUMN.      WINTER.



# FLOWERPOWER

## EDITORIAL

Letters from members to the magazine are now starting to become more numerous and contain all sorts of interesting items, many thanks and please keep them coming.

We have had a large number of replies in response to our request for information on your cars but we are far from complete yet so if you have not yet sent us the details on your car please do so especially the overseas members.

I hope you have all had an enjoyable Christmas and are looking forward to another year of rallies and meets, I managed to get into my garage and spend some time on my own flowers restoration.

The way things are going I hope to make the national rally in my own car this year, after three years of re-building I have now only the re-paint and interior to fit out, but its nearly there.

Over the winter period I took the opportunity to have most of the bright work re-chromed, the company I used is based in Watford and is called AA Electro-Platers.

The majority of there work is commercial but one of the owners has an interest in older cars and he will take in work from classic restorers. The work is good and not overly expensive, although they will not repair damaged items or metal work which is found to be very thin after the polishing process.

As a guide the cost of stripping, polishing and replating per items is; Hub caps = £10. O/riders = £15.  
Bumpers = £70. Window frames £10. window catches and small items a couple of pounds each.

If your interested, they will accept items through the post or by red star rail link, and can be contacted at: Caxton Way. Watford Business Park. Watford. Herts: WD1-8UA. tel Watford 226662.

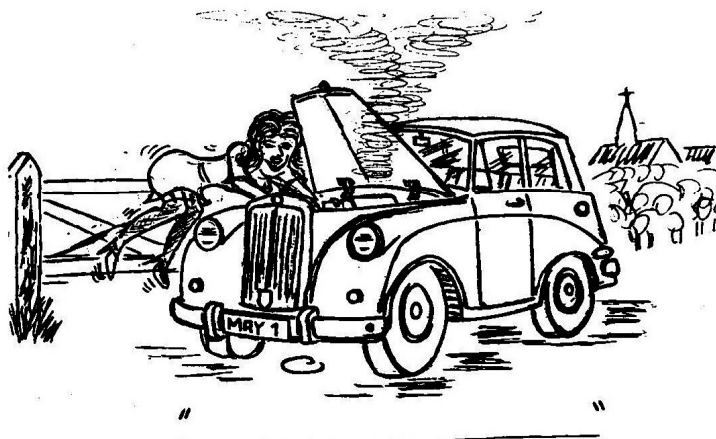

## CARTOON COMPETITION

Due to problems with the Xmas post and the cut off date of the cartoon competition in the last issue, the deadline for suggestions has been extended. So put pen to paper with your solutions, to reach the editor by May to allow results to be published in the summer issue.



## FLOWERPOWER

### IMPORTANT ANNOUNCEMENT FROM THE CHAIRMAN

#### 1990/91 SUBSCRIPTIONS

If you joined the Mayflower club before the 1st of October 1989 YOUR subscription is now due, the current rate is £8.00 for UK members and £10.00 for overseas members.

At the AGM which will be held on the Sunday the 29th of April at the Eathorpe Park Hotel, Eathorpe, the committee will be discussing an increase in the subscription rate to cover the increased cost of publishing and postage.

Overseas members (outside Europe) have asked if it is possible to send their editions of Flowerpower by air mail, this would cost the club an extra £1.00 per issue in postal charges.

If the subscription rate is increased it will be with immediate effect after the AGM, so it will obviously pay to re-new as soon as possible, Please send an S.A.E. if you require a membership card to be sent to you directly.

A renewal form can be found at the back of this issue.

#### NOTE.

AGM SUNDAY 29th APRIL 1990, EATHORPE PARK HOTEL, EATHORPE, WARWICKSHIRE. at 2pm come early to meet the committee and discuss the clubs operation.

Overnight accommodation and meals are available at the hotel

**NEW**

# **HUB CAPS**

**with centre hole**

**PRICE: £9.50 EACH OR £36 A SET**

**Enamelled Globe for fixing in centre hole and on  
Radiator Grille**

**PRICE: £7.00 OR £32.00 FOR FIVE**

*Available from the Spares Secretary*



## FLOWERPOWER

### DVLC UPDATE

"Lost" registration numbers: first, an apology to the RAC, the British Motor Industry Heritage Trust, the MG Owners Club, the Jaguar Drivers Club and the Vintage Motor Cycle Club whose involvement was not mentioned in the hasty interim News Sheet we sent to subscriber organisations.

This followed the news early in October that Robert Atkins, Minister of Transport, had agreed in principle to a change in policy to enable "lost" registration numbers to be re-issued in genuine cases, albeit on a non-transferable basis.

The delegation which met the Minister, and which persuaded him to this change, comprised representatives of the organisations listed above as well as the Federation Chairman, Derek Grossmark, who had laid the ground for the change in policy at a meeting in 1988 with the then Minister, Peter Bottomley.

Robert Atkins was very much more receptive to the ideas being put forward than his predecessor had been, and was very keen to be helpful to the movement. Officials of the DVLC met with representatives of the same organisations (the Federation being represented by Deputy Chairman, Tom Ryland)

In November at a meeting chaired by Jack Smeaton of the RAC, to discuss the implementations of the new policy. The DVLC officials were very willing and co-operative, but face much greater problems than might at first be thought.

First, DVLC has to be cost effective: re-issuing old plates is a very small part of the DVLC operation and so can warrant only a very small portion of resources. Second, there is still considerable concern about fraud.

Whilst making re-issued numbers non-transferable, the key to the new policy, removes the obvious possibility of fraudulent applications for gain by selling the re-issued number, there is the very real risk that the unscrupulous will use the re-issuing facility to give authenticity to fake vehicles, whether those built up from original parts, replicas or "clones."  
(two or more vehicles made from one original one)

In order to overcome this problem, DVLC will be placing a great reliance on the integrity of Clubs to vouch for the pedigree of vehicles. An integral part of the re-issuing procedure will be authentication of the application by authorised Clubs. Applicants will have to provide documents to an official of an appropriate Club for checking.

DVLC still have much work to do in preparing their computer for this change in policy. The final details of how the new system will work, and when it will start, will not be known until mid-1990.

Our advice to anyone wishing to apply for the re-issue of an old number is to wait until the new policy has been implemented before writing to DVLC. Premature applications will probably lead to disappointment and will occupy time of officials at Swansea who could be better employed working on the implementation of the policy.



## FLOWERPOWER

Those with a pressing need to register a vehicle for road use may have to be willing to accept an age related number, but before doing so, they should ensure that such acceptance will not prejudice a claim for the original number at a later date.

---

## *LETTERS TO THE EDITOR*

Letter from J P Moat to Chairman

You may recall me writing to you earlier this year regarding the Mayflower HFM 75 which I was endeavouring to get into the Swansea computer. Well, thanks to your efforts and the assistance of the archivist of my local old motor club we have now been successful.

It now remains for me to put the engine together, I'll enjoy that and get it roadworthy.

I see from the summer edition of "Flower Power" that a survey into the numbers of cars left is being sought - I am sure this will help in future requests to Swanswea - provided we don't find too many.

Once again, many thanks for your help. I hope to see you sometime at one of the events one day.

### LETTERS

Lionel De Villers, has written from Montreal in Canada, he tells of two Mayflowers he has found about forty miles north of Montreal in a town called St Jerome.

Both cars are reported to be in a restorable condition and are complete, there is some rust about and both are sitting in a shed alongside an old Jaguar and a large Rolls !.

Lionel has also an advertisement for a third car which appeared in a local paper in Quebec city, it is advertised as being in good condition but with a Datsun engine, (heaven forbid) still hope is to be found in that the seller still has the original engine in his garage.

Anyone interested should contact Lionel De Villers at:  
369 Mousseau.  
Montreal.  
Quebec.  
HIL-4TB.  
Canada.



# FLOWERPOWER

## LETTERS

Bert Lacey has written and enclosed a copy of an account for a de-coke, MOT, and a number of small repairs effected in 1966.

The work was carried out by a small garage in Winslow Bucks; in fact the village is only a few miles from my own home.

Now take a look at the cost of the work, can you imagine the cost now if you could a garage willing to do it.

I wish I could find spares at those prices now.



## ALF CHAPMAN

MOTOR ENGINEER - REPAIRS - TYRES - ACCESSORIES

14a HORN STREET, WINSLOW, BUCKS.

Telephone: WINSLOW 2782

A/C No. 1427

Mr.S.Gillard,  
46, station road,  
WINSLOW.  
Bucks.

5th May, 1966.

N.B. Customers care are stored & driven by our staff entirely at owners risk.

### TRIUMPH MAYFLOWER.

Decarbonise & grind in new exhaust valves. Repair steering box in situ. Fit re-lined brake shoes all round, freeing off siezed cylinders as required. fit new brake hoses all round. Fit new rear hub seal. Fit new handbrake cable. Bleed and adjust all round. Change engine oil. Tighten loose track rod ball joint. Re-fit front number plate. Take car to Buckingham for M.O.T. Test. ... £ 25. 0. 0.

### PARTS SUPPLIED:-

1 Gasket Set	16	0	
4 Exhaust Valves	2	2	0
6 Pts. Castrol XL		16	6
1 Brake Cable		12	0
1 Set Re-lined Brake Shoes	6	2	0
3 Brake Hoses	1	14	5
1 Hub Seal		6	6
M.O.T. Test & Certificate		15	0

£ 38 4 5

RECEIVED WITH  
THANKS

OS abett



## FLOWERPOWER

### LETTERS

Former club secretary and chairman Phil Hall writes to say that at the 1989 Craven Old Wheels Society meeting at Broughton Hall, Skipton, eight flowers represented the club and thanks should go to Neil Kershaw and John Oglesby.

This was followed by another eight flowers at the club's national rally, Now as I see it, if our national rally only rates the same turn out as John's and Neil's efforts then something is wrong.

I believe I know what it is,! ADVERTISING so fellow members start by marking in your diaries our next national rally.

JULY THE 22nd AT BLENHEIM PALACE, instead of eight flowers perhaps sixteen plus, so don't let us down BE THERE and I will see you all.

Phil Hall.

# **NATIONAL RALLY**

**SUNDAY JULY 22nd 1990**

**BLENHEIM PALACE**

**SUPPORT *YOUR* CLUB AND BE THERE!**

### LETTERS

" A Shocking tale"

Some weeks ago I had occasion to phone the spares secretary with regard to the rear shock absorbers, although they are listed in the in the spares list they are not priced.

I was told they were not priced because there are none available, however my local branch of G.K.N. were very helpful to me when trying to get spares for the Mayflower.

In this instance they came up with the identical item, from a modern vehicle, the shock absorbers from a Bedford Midi Van can be used without any difficulty.

Our thanks to Mr DL.Pragnell member 599 for this information.



# SPARES UPDATE

## AMENDMENTS TO JULY 1989 PRICE LIST

### NEW ITEMS

Thrust Washer set	100327	2.50
Shim (Crankshaft)	27138	0.40
Drain Tap (Engine Block)	61478	2.75
Regulator (up to TT6155)	101929	24.00
Side Lamp Lens and Rim	70339	2.90
Side Lamp Rim	70341	1.40
Stop Tail Lamp Glass	500496	1.50
Starter Motor Parts Kit	70391	1.50
Trunnion Grease Nipple	56934	0.40
Set Screw, drum to hub	V5435	0.30
Set Screw, rear axle	100878	0.30
Abutment for Accelerator Cable	101614	0.30
Radiator Badge	101042	7.00
Headlamp Light Unit	500518	15.00

### PRICE CHANGES

Timing Chain Locking Plate	36411	0.20
Starter Ring	201350	28.00
Master Cylinder Repair Kit	500900	7.00
Master Cylinder	300868	25.00
Front Wheel Cylinder	201098	14.00
Front Wheel Cylinder	201099	14.00
Rear Wheel Cylinder	200914	14.50
Rear Wheel Cylinder Repair Kit	TMC180	5.50
Side Lamp Glass	70340	1.50
Hub Grease Cover	102689	2.50
Pinion Oil Seal	100898	2.80
Gearbox Oil Seal	60215	2.50
Spare Parts Catalogue	TMC153	10.00
Doorway Surround Rubber	700242/3	10.00
Rear Side Window Rubber	800099/100	10.00

### NO LONGER AVAILABLE

Bottom Hose	200280
End Clip	601179
Carburettor	201209
Wheel Brace	101761
Clutch Driven Plate	500436
Heater Control Unit	700381

### AVAILABLE SOON

Hub Cap, with centre hole

-

9.50



LETTERS

Glyn Morris writes from Harare and includes two photographs of his pride and joy, the first shows his car in the 23rd annual vintage Umtali car rally.

The second shows his flower snuggling up alongside an expensive attempt at a Mayflower lookalike !.

As far as Colin knows his flower is the only example in his part of the world, he also has a spare engine block, sprocket and timing chain if anyone is interested, they are free to anyone who can arrange transportation.



GLYN MORRIS'S MAYFLOWER alongside the lookalike !

# FRONT HUB BEARING KIT

Inner and Outer Bearings and Grease Seal

PRICE £13.00 + P&P

*Available from the Spares Secretary*



# SPARES UPDATE

LETTERS

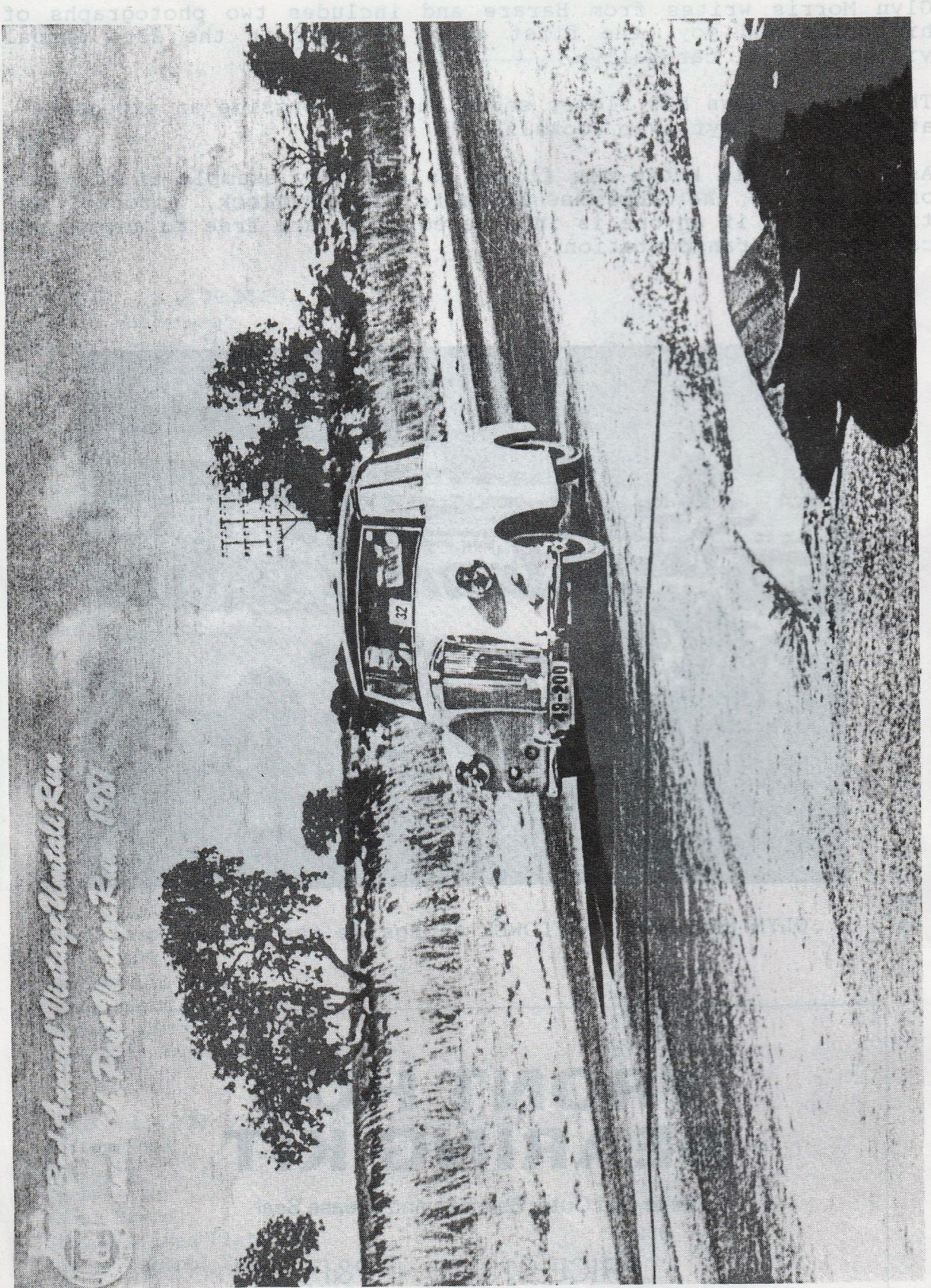

*20th Annual Vintage Umiak Run  
Crested Butte Race-Manager Ra. 1931*

Glyns car taking part in the post vintage run

Available from the Spares Secretary, I.A.V.A. Ltd. 100, 101, 102, 103, 104, 105, 106, 107, 108, 109, 110, 111, 112, 113, 114, 115, 116, 117, 118, 119, 120, 121, 122, 123, 124, 125, 126, 127, 128, 129, 130, 131, 132, 133, 134, 135, 136, 137, 138, 139, 140, 141, 142, 143, 144, 145, 146, 147, 148, 149, 150, 151, 152, 153, 154, 155, 156, 157, 158, 159, 160, 161, 162, 163, 164, 165, 166, 167, 168, 169, 170, 171, 172, 173, 174, 175, 176, 177, 178, 179, 180, 181, 182, 183, 184, 185, 186, 187, 188, 189, 190, 191, 192, 193, 194, 195, 196, 197, 198, 199, 200, 201, 202, 203, 204, 205, 206, 207, 208, 209, 210, 211, 212, 213, 214, 215, 216, 217, 218, 219, 220, 221, 222, 223, 224, 225, 226, 227, 228, 229, 230, 231, 232, 233, 234, 235, 236, 237, 238, 239, 240, 241, 242, 243, 244, 245, 246, 247, 248, 249, 250, 251, 252, 253, 254, 255, 256, 257, 258, 259, 260, 261, 262, 263, 264, 265, 266, 267, 268, 269, 270, 271, 272, 273, 274, 275, 276, 277, 278, 279, 280, 281, 282, 283, 284, 285, 286, 287, 288, 289, 290, 291, 292, 293, 294, 295, 296, 297, 298, 299, 300, 301, 302, 303, 304, 305, 306, 307, 308, 309, 310, 311, 312, 313, 314, 315, 316, 317, 318, 319, 320, 321, 322, 323, 324, 325, 326, 327, 328, 329, 330, 331, 332, 333, 334, 335, 336, 337, 338, 339, 340, 341, 342, 343, 344, 345, 346, 347, 348, 349, 350, 351, 352, 353, 354, 355, 356, 357, 358, 359, 360, 361, 362, 363, 364, 365, 366, 367, 368, 369, 370, 371, 372, 373, 374, 375, 376, 377, 378, 379, 380, 381, 382, 383, 384, 385, 386, 387, 388, 389, 390, 391, 392, 393, 394, 395, 396, 397, 398, 399, 400, 401, 402, 403, 404, 405, 406, 407, 408, 409, 410, 411, 412, 413, 414, 415, 416, 417, 418, 419, 420, 421, 422, 423, 424, 425, 426, 427, 428, 429, 430, 431, 432, 433, 434, 435, 436, 437, 438, 439, 440, 441, 442, 443, 444, 445, 446, 447, 448, 449, 450, 451, 452, 453, 454, 455, 456, 457, 458, 459, 460, 461, 462, 463, 464, 465, 466, 467, 468, 469, 470, 471, 472, 473, 474, 475, 476, 477, 478, 479, 480, 481, 482, 483, 484, 485, 486, 487, 488, 489, 490, 491, 492, 493, 494, 495, 496, 497, 498, 499, 500, 501, 502, 503, 504, 505, 506, 507, 508, 509, 510, 511, 512, 513, 514, 515, 516, 517, 518, 519, 520, 521, 522, 523, 524, 525, 526, 527, 528, 529, 530, 531, 532, 533, 534, 535, 536, 537, 538, 539, 540, 541, 542, 543, 544, 545, 546, 547, 548, 549, 550, 551, 552, 553, 554, 555, 556, 557, 558, 559, 560, 561, 562, 563, 564, 565, 566, 567, 568, 569, 570, 571, 572, 573, 574, 575, 576, 577, 578, 579, 580, 581, 582, 583, 584, 585, 586, 587, 588, 589, 590, 591, 592, 593, 594, 595, 596, 597, 598, 599, 600, 601, 602, 603, 604, 605, 606, 607, 608, 609, 610, 611, 612, 613, 614, 615, 616, 617, 618, 619, 620, 621, 622, 623, 624, 625, 626, 627, 628, 629, 630, 631, 632, 633, 634, 635, 636, 637, 638, 639, 640, 641, 642, 643, 644, 645, 646, 647, 648, 649, 650, 651, 652, 653, 654, 655, 656, 657, 658, 659, 660, 661, 662, 663, 664, 665, 666, 667, 668, 669, 670, 671, 672, 673, 674, 675, 676, 677, 678, 679, 680, 681, 682, 683, 684, 685, 686, 687, 688, 689, 690, 691, 692, 693, 694, 695, 696, 697, 698, 699, 700, 701, 702, 703, 704, 705, 706, 707, 708, 709, 710, 711, 712, 713, 714, 715, 716, 717, 718, 719, 720, 721, 722, 723, 724, 725, 726, 727, 728, 729, 730, 731, 732, 733, 734, 735, 736, 737, 738, 739, 740, 741, 742, 743, 744, 745, 746, 747, 748, 749, 750, 751, 752, 753, 754, 755, 756, 757, 758, 759, 760, 761, 762, 763, 764, 765, 766, 767, 768, 769, 770, 771, 772, 773, 774, 775, 776, 777, 778, 779, 780, 781, 782, 783, 784, 785, 786, 787, 788, 789, 790, 791, 792, 793, 794, 795, 796, 797, 798, 799, 800, 801, 802, 803, 804, 805, 806, 807, 808, 809, 810, 811, 812, 813, 814, 815, 816, 817, 818, 819, 820, 821, 822, 823, 824, 825, 826, 827, 828, 829, 830, 831, 832, 833, 834, 835, 836, 837, 838, 839, 840, 841, 842, 843, 844, 845, 846, 847, 848, 849, 850, 851, 852, 853, 854, 855, 856, 857, 858, 859, 860, 861, 862, 863, 864, 865, 866, 867, 868, 869, 870, 871, 872, 873, 874, 875, 876, 877, 878, 879, 880, 881, 882, 883, 884, 885, 886, 887, 888, 889, 890, 891, 892, 893, 894, 895, 896, 897, 898, 899, 900, 901, 902, 903, 904, 905, 906, 907, 908, 909, 910, 911, 912, 913, 914, 915, 916, 917, 918, 919, 920, 921, 922, 923, 924, 925, 926, 927, 928, 929, 930, 931, 932, 933, 934, 935, 936, 937, 938, 939, 940, 941, 942, 943, 944, 945, 946, 947, 948, 949, 950, 951, 952, 953, 954, 955, 956, 957, 958, 959, 960, 961, 962, 963, 964, 965, 966, 967, 968, 969, 970, 971, 972, 973, 974, 975, 976, 977, 978, 979, 980, 981, 982, 983, 984, 985, 986, 987, 988, 989, 990, 991, 992, 993, 994, 995, 996, 997, 998, 999, 1000



## FLOWERPOWER

Eric Watts, has written written and enclosed a photograph of his flower which he purchased in August 1989, it had a current MOT and he tells us that it is in very good condition for the year, the car was first registered in October 1952.

Eric's son used the car for a few months and attracted a lot of attention in the Bristol area, since then Eric has started a restoration program. To date the seats have been recovered and he is now in the process of replacing the floor coverings and sealing rubbers.

Unfortunately at some time in its history the body had been rather badly brush painted, however this seems to have had a preserving effect on the car, although it is to be re-sprayed in the future prior to its attendance at rallies.

The only problem has a blown head gasket, which was replaced, and after having the head skimmed has given no more trouble.





## TECH-TIPS

This month's article is a reprint from an old issue of the Standard Car Review, dealing with the gear lever assembly, it shows both the fork and pin type of lever.

Incidentally the club has a few of the earlier levers in stock at a cost less than that of

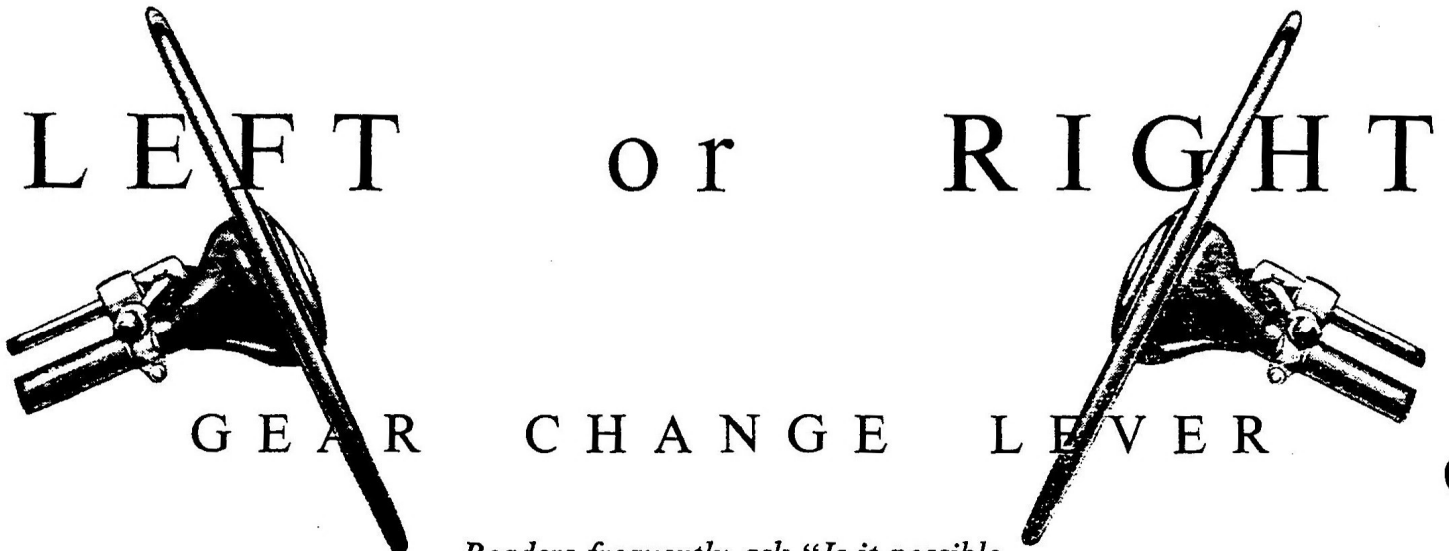

*Readers frequently ask "Is it possible to change the gear lever position from one side to the other?"*

THE Standard Vanguard, Triumph Renown and Triumph Mayflower are all fitted with steering column gear change levers. During the past two years the position of these levers has been standardised with the lever pointing towards the centre of the car, whether the driving position is right- or left-handed. This coincides with most other makes of cars whether English or American.

We are frequently asked by owners if it is possible to alter the gear lever position to operate from the opposite side, usually because of some disability of the left hand.

It is not unduly difficult to change the lever from one side to the other, and anyone of a reasonably mechanical turn of mind should be able to make the alteration.

We illustrate the two slightly different types of gear levers; Fig. 1 is the earlier type and Fig. 2 shows the slight modifications which were introduced in later models. Their construction can be clearly seen and with the aid of the following description we hope those who wish to change their control will be able to carry out the work without undue difficulty.

The only difference between the two types is that in type 1 (Fig. 1) the end of the lever is forked and fits into the forked end of the gear control shaft, the fork on the lever fitting over a small pin. In type 2 (Fig. 2) the end of the gear lever is rounded and this fits into a hole, *H*, in the gear control shaft, the top of which has two flats to locate the lever cap and inner sleeve assembly, otherwise the movement and operations are

identical. The following brief description and instructions for removal and replacement in the reverse positions apply whether on right- or left-hand driven cars:

The gear control lever consists of the following parts—*A*, gear lever and knob assembly. *B*, lever cap and inner sleeve assembly which is screw threaded and screws into the bush *D*; this is fitted in *G*, the gear lever clamp; which secures the assembly to the steering column. These

two parts, *B* and *D*, are not screwed together completely, consequently *B* is free to rotate in either direction in *D*. The control shaft *E* passes freely through *D* and *B*. Gear lever *A* engages *E* near top of shaft, secured by fulcrum pin *C*. It will, therefore, be seen that up and down movement of gear lever *A* lifts control shaft *E* up or down, whilst horizontal movement of lever *A* rotates gear control shaft *E*, the two movements necessary to change gear.

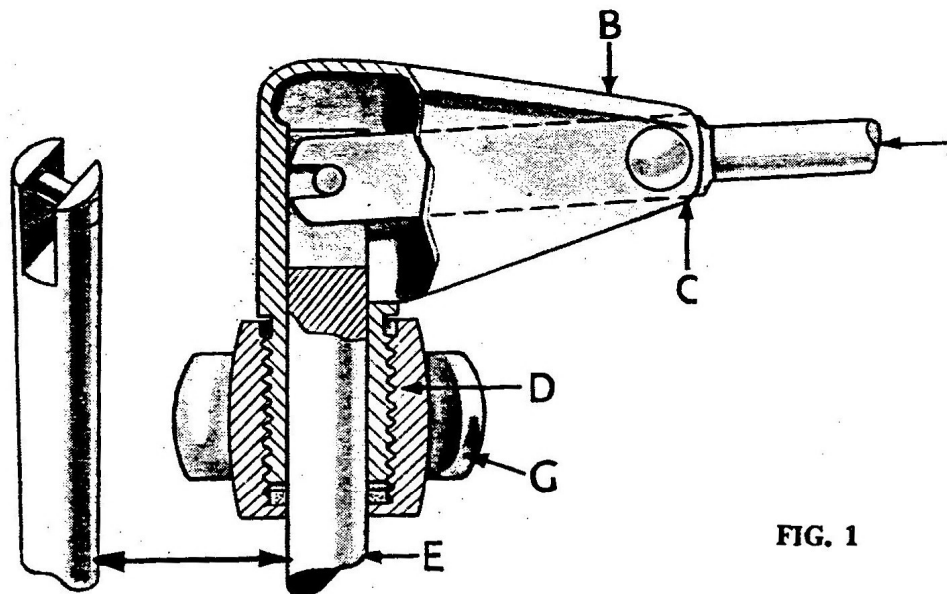

FIG. 1



rechroming, it is quite easy to measure and saw through the lever between point C and the fork, as seen in Fig. 1.

The pin action can then be welded on to the earlier shaft, it works, I have done it with my own restoration.

**To dismantle and reverse.**

(1) Remove gear lever A by withdrawing fulcrum pin C (after removing circlip, see Fig. 3). (2) Rotate cap and inner sleeve B through 180 degrees to the opposite side of the steering column. (3) Re-insert gear lever A and fulcrum pin C. Unfortunately the change is not quite so simple as it sounds, as in most cases, especially with the later type lever, it will be necessary to remove the steering wheel in order to give room for the cap to be lifted off its flats and rotated to the opposite side.

**Removing Steering Wheel.**

To remove steering wheel we refer to sketches 4, 5 and 6. First remove the three screws indicated in steering wheel hub, and gland nut at bottom of steering box. The complete centre control for horn and trafficator switches can then be withdrawn after the connections for the horn and trafficator wires, which pass through the centre of the stator tube, have been detached at the lower end. Within the steering wheel hub will be found a large nut which must be removed. The wheel is then free to be withdrawn from its taper and splines. A proper extractor should be used for this as tapping on the wheel hub may easily damage the hub, unless great care is taken.

With the steering wheel removed and securing clamp G slackened (Figs. 1 and 2), the whole unit can be lifted, B turned to desired position and all parts then replaced. If difficulty is found in threading the electrical wires through the stator tube a wire may first be threaded through, the wires attached to this and pulled through like a cleaner in a rifle barrel.

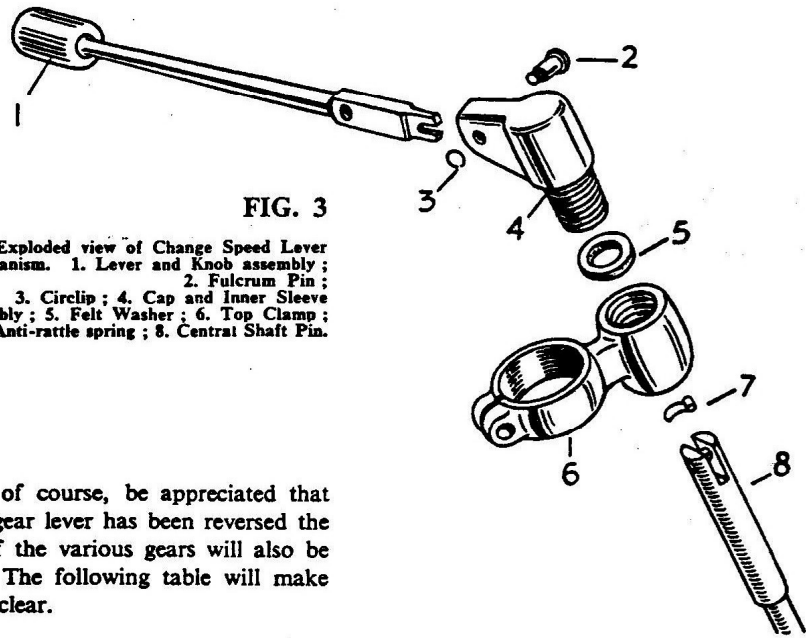

It will, of course, be appreciated that when the gear lever has been reversed the position of the various gears will also be changed. The following table will make this point clear.

Gear positions— lever pointing towards centre of car. Right- or left-hand steering.	Gear positions— when lever reversed.
Top—Down and back.	Top—Down and forward.
2nd—Down and forward.	2nd—Down and back.
1st—Up and back.	1st—Up and forward.
Reverse— Up and forward.	Reverse— Up and back.

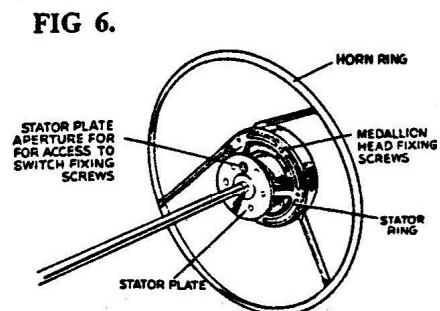
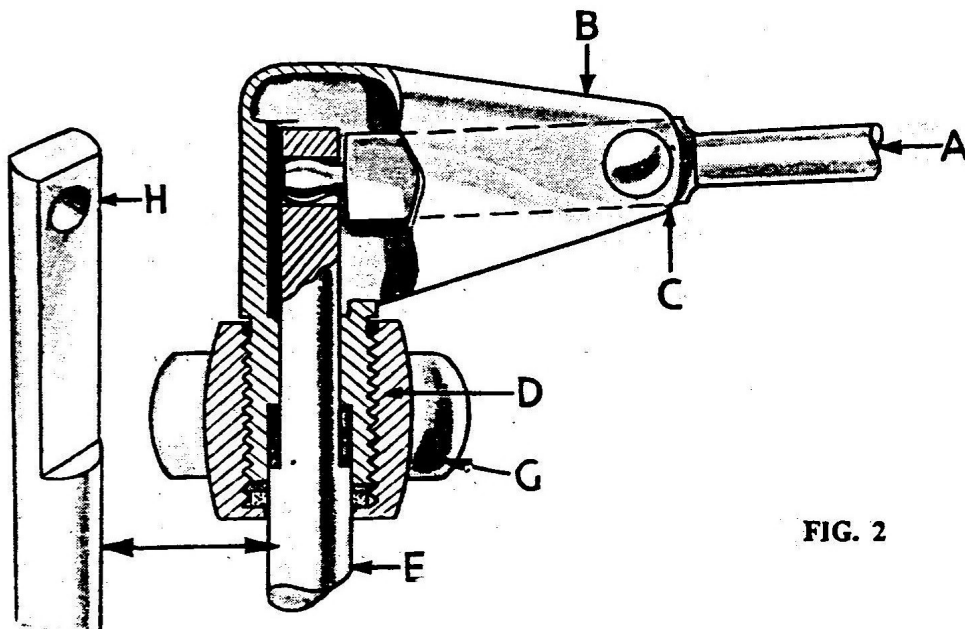
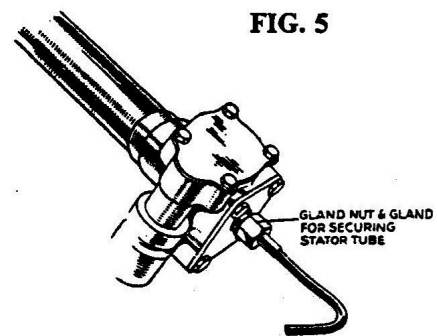
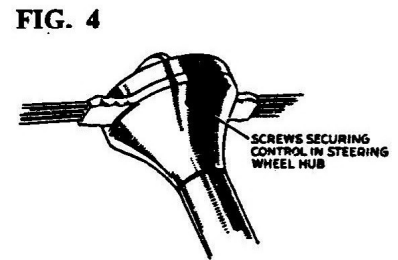



## FLOWERPOWER

### LETTERS

Colin Eastwood was at one time the chairman of the Pre-1940 Triumph Owners Club and has written to us with some photographs of a recent find he and his wife Jean made in Samos.

"We were on the Greek island of Samos which is about two miles from Turkey last October, and spotted a Mayflower alongside the main road which heads into the mountains from a small fishing village called Koumaradei.

The car was just visible from the road under two walnut trees and close to a shed full of Turkeys, the cars was complete as far as I could tell but it has a non-standard radiator grill".

Colin Eastwood.

### THE MAYFLOWER FOUND ON SAMOS





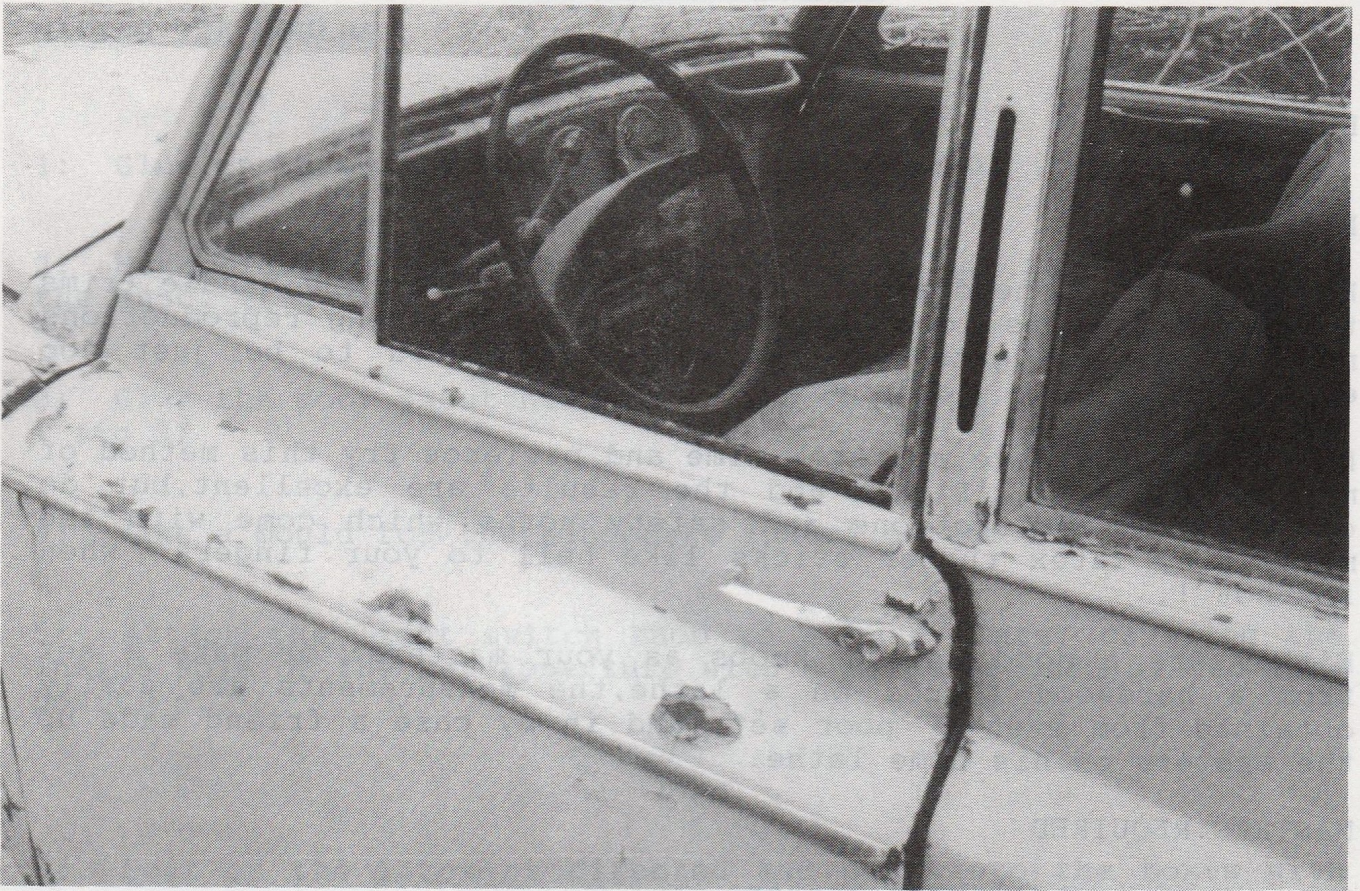

Now take a closer look at the photographs which Colin sent, there are a few non-standard parts on the car: steering Wheel, Grab Handles and Chrome Door trim not to mention the Radiator Grill. If there are any detectives amongst you perhaps you can supply the answers.

Is it a rare version or has it been kept alive with odd parts !.





# FLOWERPOWER

## BODY-SHOP

### Plastic knobs

How many of you need a good set of plastic knobs and handle trims to make your cars look better, the cost of having reproductions made was investigated by the club but proved to be just too expensive to be a viable proposition.

However if you have a little time and patience try this method of making your own, I did and the results are excellent, but do observe the instructions and safety notes which come with the materials, latex rubber sticks like hell to your fingers when its hot !.

Either use a good set of knobs as your masters: or make a set from a hardwood turned on a lathe, the measurements are easily obtained from even a poor set, and in my case a friend made up the masters on his home lathe.

### MASTERS REQUIRED

One set of control knob masters.  
One light switch knob in good condition.  
One light switch insert. (home made)  
One door escuthin master.  
One handbrake insert master.

Balsa wood sheet.  
Balsa wood glue.  
Latex rubber compound.  
(Gelflex vinyl compound. from most model shops)

Glass fibre resin.  
(Supercast resin natural. from most model shops)

Modelling paint.  
(Humbol, again from most model shops)

I filled the cracks in my light switch and polished it, before using it as my master, this meant that the engraved letters were also reproduced.

It is a good idea to make the knob masters slightly oversized as there is some shrinkage as the resin hardens.

If you use wooden masters first seal them with a teflon spray or coat with varnish, this prevents them sticking to the latex and stops air bubbles forming when the hot rubber is poured.

## **BODY SHOP SUPPLEMENT**

Fits into the Workshop Manual Ring Binder

*Price £4.00 + Post & Packing*

*Available from the Spares Secretary*



# FLOWERPOWER

## MAKING THE MOULDS

- 1: Glue or screw the knob to a balsa baseboard. (fig 1)
- 2: Make sides to form a box, allow at least one inch deeper than the knob. (fig 2)
- 3: Glue the door escutcheon to a baseboard and make up a box. ( fig 3)
- 4: Make a mould for the handbrake insert as above.
- 5: Attach the light switch knob to a base plate, covering the inside hole of the key apperture with a peice of card glued into position.
- 6: Heat up the latex as directed and pour into the boxes with care. Leave for at least three hours to cool and harden.(fig 4)
- 7: Remove the sides of the box, then Break off the base leaving the knob in position.
- 8: Gently release the knob by working the rubber mould when the knob is loose press from underneath to release and remove from the mould.

KNOB ATTACHED TO BASEBOARD.

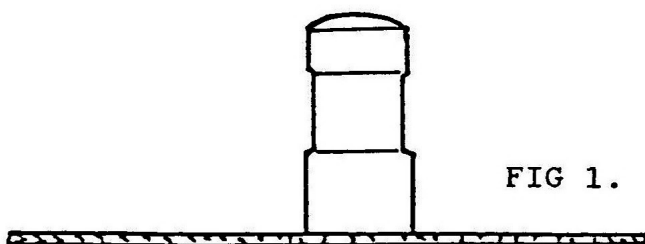

BOX CONSTRUCTED

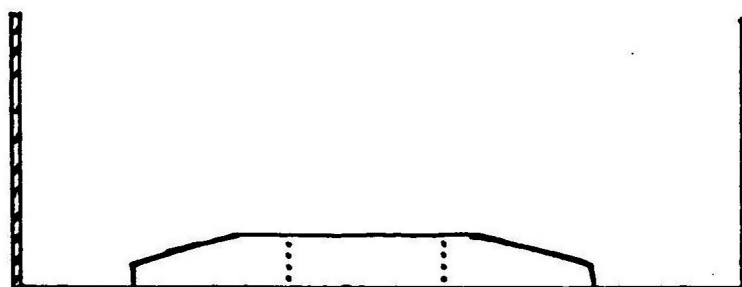
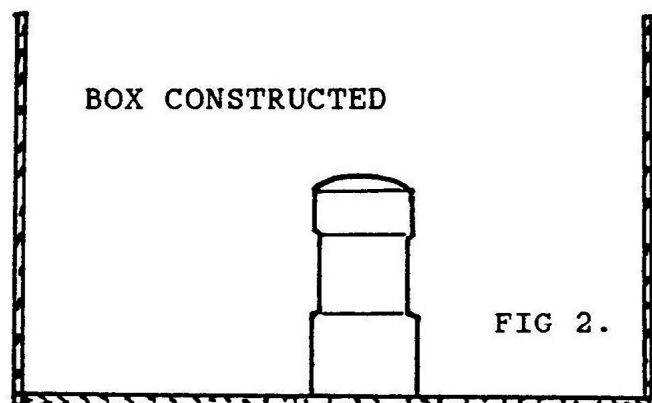



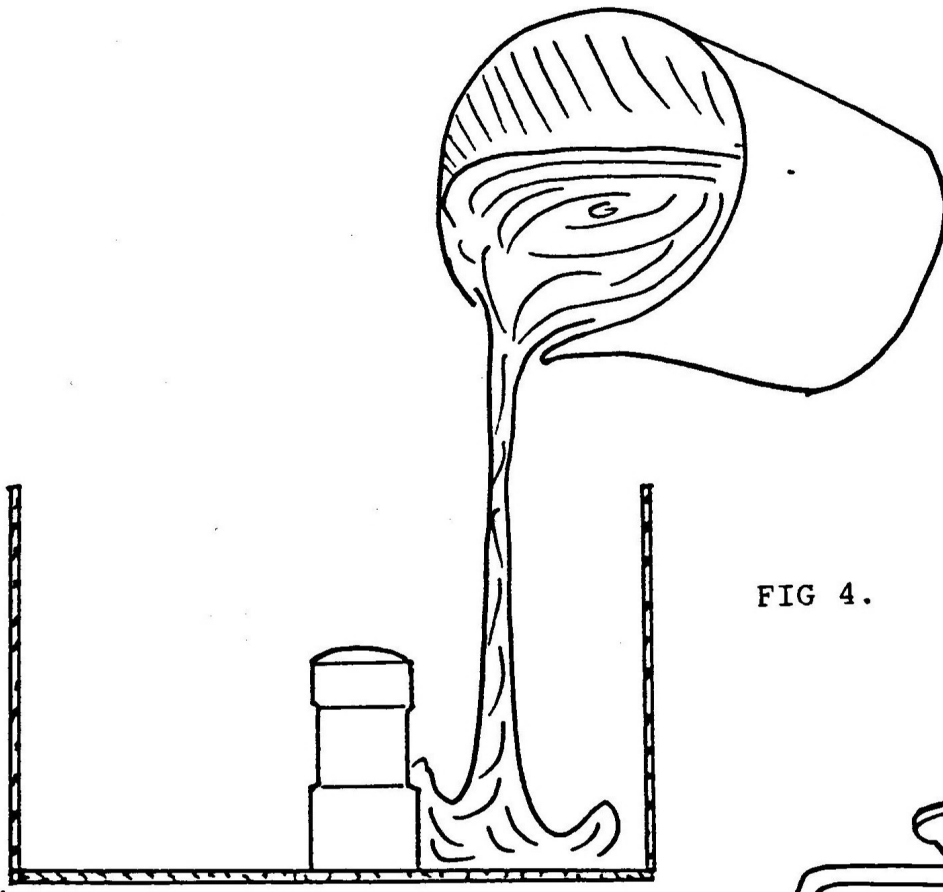

FIG 4.

POUR LATEX RUBBER INTO CASTING BOX

CLAMP AN ALLEN KEY IN  
CENTRE OF MOLD  
BEFORE POURING THE RESIN

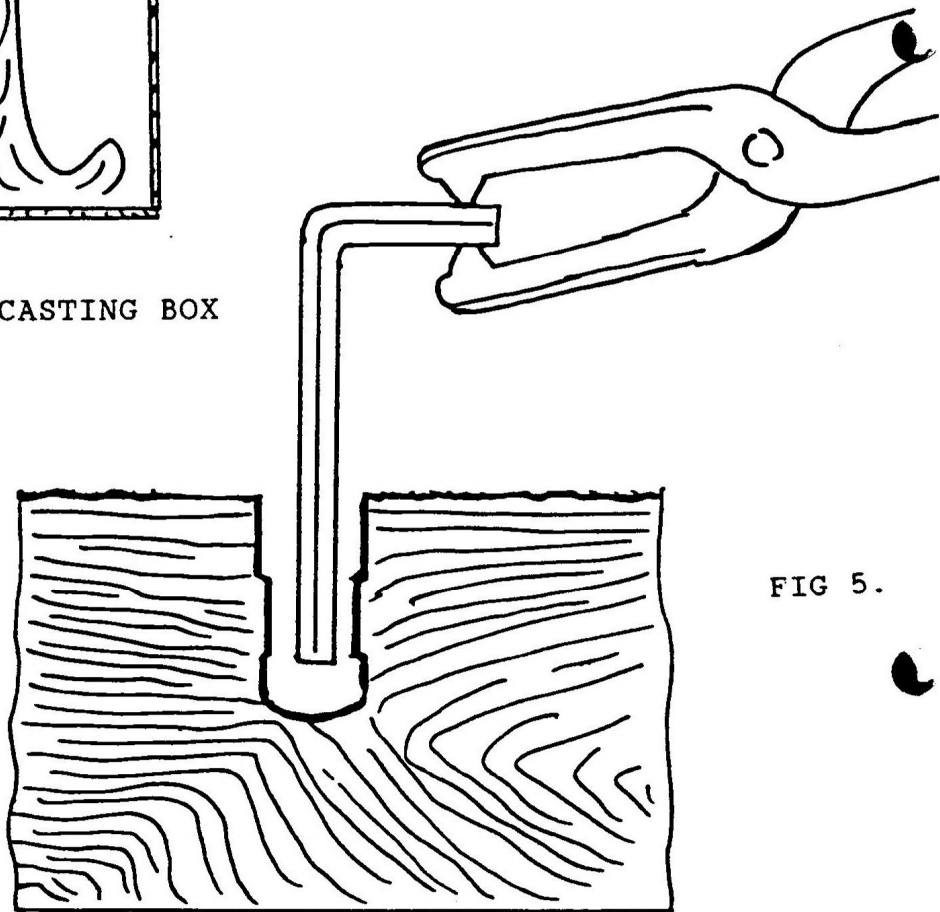

FIG 5.

PREPARE THE RESIN

- 1: When you buy the resin choose a clear version.
- 2: Mix your paint to the desired colour "Ivory" and add to the the resin. This way all the castings will be the same colour and shade when completed.



## FLOWERPOWER

### CASTING THE KNOBS

- 1: When casting the knobs select an Allen key the same size as the switch spindles and make a jig as shown.  
(fig 5)
- 2: Lightly grease the shaft of the Allen key.
- 3: Mix up a quantity of resin and pour.
- 4: Once the casting has hardened withdraw the Allen key and release the knob from the mould.
- 5: The knob should be examined for the indentation of the peg hole, and then drilled out.
- 6: The knob should now be smoothed with wet and dry paper and polished with T-cut.
- 7: Cast the handbrake insert.
- 8: Cast the door escutcheon mouldings, when releasing press the centre of the latex mould with your thumb to release.

### **FOR SALE/ WANTED ADS**

This service is available free for all club members. Take advantage of it. It makes the magazine a lot more interesting as well as selling or finding that particular part!

Send your copy to the Magazine Editor. A small charge will be made if a photograph is required.

**TRY IT!**

*AT LAST!*

### **THE TRIUMPH RADIATOR BADGE**

**Price £7.00 + p&p**

*Available from:  
The Spares Secretary*



## FLOWERPOWER

### CASTING THE LIGHT SWITCH

This is the most difficult item to make and requires patience.

1: Make up the insert for the light switch as shown and check the fit inside the original knob.

2: Construct a jig to hold the insert steady inside the mould as shown. (fig 6)

3: When positioning the insert either measure or gauge the the height above the mould bottom. I made this measurement by the use of eye and it worked well.

4: Pour the resin and when set release the rubber mould before the insert, release the insert by pressing thru the centre of knob with your thumb.

5: You should find that the mould will reproduce the engraved letters and show the mark for the peg, which you should now drill out

6: Smooth and polish the casting, both inside and out to achieve a good fit.

NOW AVAILABLE

# **LOOSE LEAF WORKSHOP MANUAL**

Reproduced Workshop Manual in PVC Ring Binder

**Price £15.00 plus £2.50 post & packing**

*Available from the Spares Secretary*



INSERT FOR THE LIGHTING SWITCH KNOB

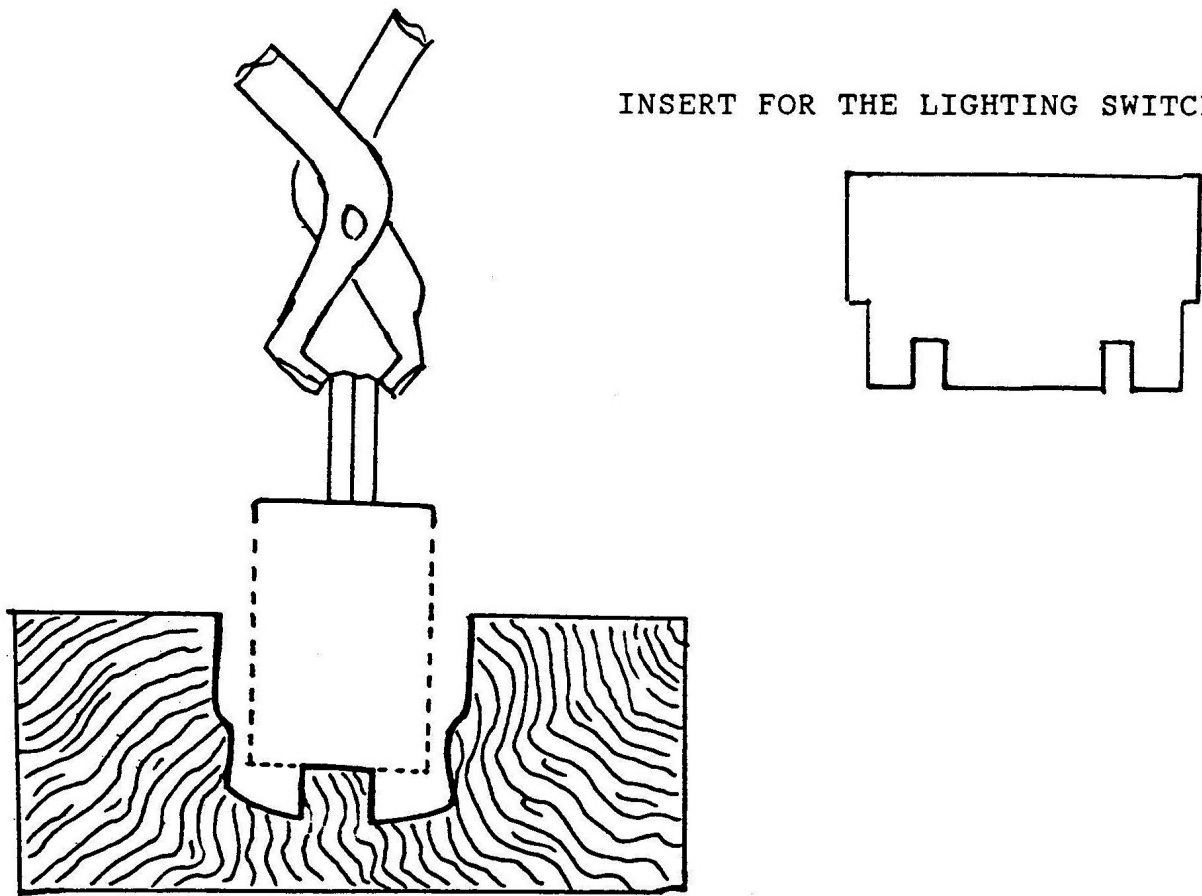

INSERT CLAPMED INPLACE INSIDE SWITCH MOLD  
BEFORE POURING THE RESIN

FIG 6.

After making your castings you may find them a little bright, to tone down use varnish which gives an aged effect.

If you make a mistake with the latex moulding you can cut it up and re-melt it for your next attempt, not so however with the resin, I made several before I selected the final set.

I had hoped to produce a number of castings for sale by the club but the time required the produce them makes it impractical, I may be able to bring along some moulds to the national rally if anyone requires them.

If you should need any advice on the making of these knobs please contact me, they seem to be quite strong enough for use as a number of prototypes are still in use by club members without failure so far.

ed.

## WINDSCREEN RUBBERS

Windscreen, Side Rear Window and Door Surround Rubbers  
now available

*Available from Spares Secretary*



**NEW REPRINT**

# **SPARE PARTS CATALOGUE**

**180 pages packed with all part numbers along with  
diagrams and illustrations**

***A must for any restoration project!***

**PRICE: £9.50**

***Available from the Spares Secretary***



***Mark Norris in the Florida sunshine with his collection of cars***



# FLOWERPOWER

## LETTERS

G.Hagger member 230, has written to advise any members that may be visiting Wales this year, that bed & breakfast accommodation is available with safe parking for old or new cars from Easter.



Tel: (0286) 881170

## **NORTH WALES**

Bed & Breakfast or  
Bed, Breakfast & Evening Meal.

With view of Snowdonia through  
Nantlle Valley surrounded by mountains  
and in easy reach to the beach of  
Caernarfon Bay.

MRS G.E HAGGER,  
COED MADOG FARM,  
TALYSARN,  
CAERNARFON,  
GWYNEDD,  
LL54 6HY.



FLOWERPOWER

SALES / WANTS

1953 Mayflower for restoration, £450.00 O.N.O.

Contact Adrian Meads at; 7 St Christophers Way.  
Burnham on Sea.  
Somerset.  
TAB-2PD.

0272-797359.(W).  
0278-783961.(H).

.....

Engine block, timing sprocket and chain.(see letters)

Glyn Morris, PO Box GD-3.  
Greendale.  
Harare.  
Zimbabwe.

.....

Wanted 4 resonably dent free over-riders and two interior door pulls. (any condition trim)

reply to

P.Norton 10 Kenyon Close.  
Bromsgrove.  
Worcs:  
B60-2DL. tel.77392.

.....

A flower originally bought as a source of spares, but could be restored, complete but in pieces. It has a good running engine and has been stored in a garage for the past couple of years.

If you are interested contact:

DC.Tilling.  
113 Worsbrough Road.  
Birdwell.  
Barnsley.  
South Yorkshire. S70-5RF. tel.0226-288504.

---

WANTED

Starting Handle, Positive earth radio, preferably an original one  
also screw type ignition coil

*Details to:*

Lionel de Villiers, 369 Mousseau, Montreal, Quebec, Canada H1L HT8



FLOWERPOWER

SALES \ WANTS

If any member is interested in purchasing a first issue manual for the Mayflower, date inside reads 1945 ! contact :

Mr Walter Heap tel : 061-202-4109.  
2 Crestwood Walk  
Collyhurst  
Manchester  
lancs. M10-7TW

.....

Has anyone a Mayflower for sale, preferably in sound condition although some work is not objected to:

Please contact one of our carless members with details:

M.Williams. (member 620)  
60 Bellhouse Road.  
Eastwood.  
Leigh-on-Sea.  
Essex.  
SS9-5NH.

ANNUAL SUBSCRIPTIONS	
NAME.....	M/No.....
ADDRESS.....	
.....	
.....	
.....	
Please complete the following information for use with the DVLC.	
Reg No.....	Commission No.....
Date first registered.....	

I will/will not be able to attend the AGM on the 29th of April 1990. (please delete as applicable)

Cheques should be made payable to the TMC.  
UK members = £8.00 O/seas members = 10.00  
To: T.Gorden, membership secretary, 12 Manor close. Houghton.  
Preston. Lancashire. PR5-OEN.



DON'T  
FORGET



SUNDAY  
JULY 22nd