

Triumph Mayflower Club



Worldwide Membership

WINTER ISSUE 2011 No. 139



FLOWER POWER

THE TRIUMPH MAYFLOWER CLUB

Club Officials for 2011-2012

<i>LIFE PRESIDENT</i>	Peter Benfield, Northallerton, North Yorkshire Tel: 01609 761260
<i>CHAIRMAN</i>	Howard Pryor, High Barnet, Herts - Tel: 020-8440 8623 E-mail: howard.pryor@tiscali.co.uk
<i>VICE CHAIRMAN</i>	John Castle, Hinckley, Leics - Tel: (01455) 613041 E-mail: john_castle@btinternet.com
<i>GENERAL AND MEMBERSHIP SECRETARY</i>	John Oaker, 19 Broadway North, Walsall, West Midlands WS1 2QG - Tel: (01922) 633042 E-mail: johnchoaker@btinternet.com
<i>NEW SPARES SECRETARY</i>	John Gogay, Cherry Hinton, Orchard Way, Wilmington, Kent DA2 7ER - Tel: (01322) 221493 E-mail: jgogay@aol.com
<i>TREASURER</i>	Paul Norton, Bromsgrove, Worcs - Tel: (01527) 575651 E-mail: tvs520@hotmail.co.uk
<i>EDITOR</i>	Nico ten Wolde, Meernijk 110, 3454 HV De Meem, The Netherlands - E-mail: mail@nicotenwolde.nl
<i>RALLY SECRETARY</i>	John Castle, Hinckley, Leics - Tel: (01455) 613041 E-mail: john_castle@btinternet.com
<i>SECONDHAND SPARES</i>	Brian Redshaw, Darlington, Co Durham - Tel: 01325 262567 E-mail: brian21250@yahoo.co.uk
<i>REGALIA SECRETARY</i>	Fred Newman, Tenterden, Kent - Tel: 01580 765951 E-mail: frederick.newman1@btinternet.com
<i>CLUB HISTORIAN</i>	Steve Coulman, Messingham, N. Lincs - Tel: (01724) 762061 E-mail: mayflowerhistorian@nicouls.globalnet.co.uk
<i>TECHNICAL OFFICERS</i>	Malcolm Barnsley, Aylesford, Kent - Tel: 01732 849140 E-mail: judy.barnsley@hotmail.co.uk Larry Spouler, Richmond, BC, Canada - Tel: 1-604-272-7250 E-mail: spoulers@shaw.ca
<i>CO-OPTED MEMBERS</i>	Maurice Wilkes - E-mail: boundarylodge@gmx.com Clive Lungmuss - E-mail: Lungmuss@aol.com
<i>WEBMASTER</i>	Robert Gannon, Hockessin, Delaware, USA - Tel: 1-302-234-1131 E-mail: trsix74@comcast.net

*When writing to a committee member and you require a reply, please enclose a Stamped Addressed Envelope
Please note that all the above committee members fulfil their positions in their spare time and not
as a full-time occupation, so when contacting them other than by letter, please ensure that
you choose a reasonable time of day*

FLOWER POWER
CONTENTS

EDITORIAL	Page 2
RUBY THE CUSTOM CAR	Pages 3 and 4
LETTERS	Pages 5, 7, 10 - 11, 14, 15
IS THERE A DIPSTICK IN YOUR REAR END?	Page 6
THE SAGA OF MAGGIE MAY	Pages 8 - 9
RALLY NEWS	Page 15

*Cover: Sculpture made from old car parts by Australian artist James Corbett.
Spot the Triumph badge!*

The information contained within Flower Power is the view of the writers and not necessarily those of the editor or the Mayflower Owners Club. Every effort is made to ensure the accuracy of the information contained, however use of such information is entirely at the members own risk and neither the club nor any individual shall in any way be liable for injury, loss or damage resulting directly from the use of such information.

ANNUAL GENERAL MEETING

The Triumph Mayflower Club Annual General Meeting will be held on Sunday, March 25, 2012 at the Holiday Inn in Tempus Way, Walsall WS2 8TJ West Midlands at 2.00 pm (room available from 1 pm). This is the venue we used last year. The location is superb being almost immediately off the M6 at Junction 10. All members are welcome to attend and to have a say and indeed it would be great if anyone felt they could volunteer a little help in the running of the club. This is your opportunity to come along and say so. The committee, as is usual, will offer there positions for re-election and any new nominations or offers to stand again for positions are taken on the day without too much formality. If necessary a vote is taken to satisfy our constitution. We shall this year be looking for a Chairman and if anyone is interested in taking on New Spares Secretary as John Gogay is looking to retire after 32 years!

SUNDAY 25th MARCH 2012

**Holiday Inn, Tempus Way
Walsall WS2 8TJ at 2.00 pm**

Editorial

LUCKILY WE have had some beautiful days in the last few months, so I was able to take my Mayflower out for a few runs. It ran great until the last run. It looked like it was misfiring at certain revs so I ordered a new condenser, points, rotor and distributor cap from our Spares Secretary. I received the new parts really quickly (thanks John!) and replaced the old items. It seems like the Mayflower is running fine again but I will not know until spring next year when I take her out for a long trip again.

I have received quite a lot of reactions on the fitting of modern indicators! Many thanks to all the members that came up with a solution. I haven't been able to put all the reactions together into one article on time for this magazine, so have included one and the rest will be in the next magazine.

If you found other ways to improve your Mayflower please let me know, it might be interesting for other members as well!

Included with the above you will find some interesting stories in this magazine, a few pictures on a heavily modified Mayflower (although I really don't like the result) and some "wanted" items for our club members, please see if you can help them!

If you can find some spare time during the last days of this year, please take a moment to write down what you have done with your Mayflower during the past year and send it to

Welcome to new members

On behalf of the club welcome and happy Mayflowering to our new members:

1145
1146
1147
1148
1149
1150

If you have an e-mail address and wish to receive club updates electronically please send your e-mail address to John Oaker at johnchoaker@btinternet.com

me. I will include all your stories in the next magazine.

Well, I wish you all a Merry Christmas and a Happy New Year and happy motoring in 2012! Enjoy reading and please keep on writing!

Very best regards, Nico ten Wolde

Copy dates

Copy deadlines to send your articles for the next editions of *Flower Power* are March 1 2012; June 1; September 1; December 1. All correspondence should be sent to Nico ten Wolde by post or by e-mail in English, German, French or Dutch.

CLUB REGALIA

Base Ball Cap	£6.00
Key Fob	£3.00
Lapel Badge	£2.60
Polo Shirt (new style)	£11.00
Woven Badge	£2.00
Club Car Badge	£11.00
Magazine Binder	£5.00
Sweat Shirt (new style)	£16.00
Mugs	£4.00
Pens	£2.00
T-Shirt	£10.00

Plus Postage and Packaging

Available from:

Fred Newman

Pippbrook, Pope House Lane

Ashford Rd, St Michaels, Tenterden TN30 6SS

Tel: 01580 765951

Instruction Handbook

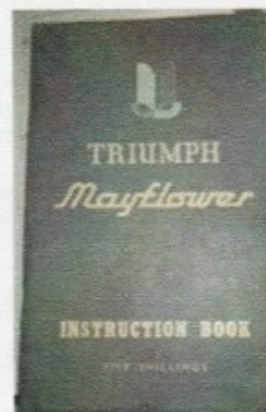

Copy of the original Handbook priced at £8.00 (Part No. TMC 152). Available from the Spares Secretary

Ruby the custom car

The following is from an eBay sale on the USA site and at the time this was extracted had a bid of \$7,000, although the reserve price was \$12,000!

This car — Ruby — is a one of a kind, custom created, inspired and partially built by the Blastolene Brothers, Randy Grub and Michael Leeds. The Blastolene Brothers created many other custom creations including the “Tank Car” for Jay Leno.

Ruby was finished by Baron Margo, a prolific Los Angeles artist. See pictures of Ruby on Baron’s website with the artist at the wheel.

Ruby sits on a Triumph chassis and has a four-cylinder engine although not Triumph. Exact mileage is not known. Beautifully designed and custom built black Carson style top, skirted aluminum fenders front and rear, and custom aluminum nose.



FLOWER POWER

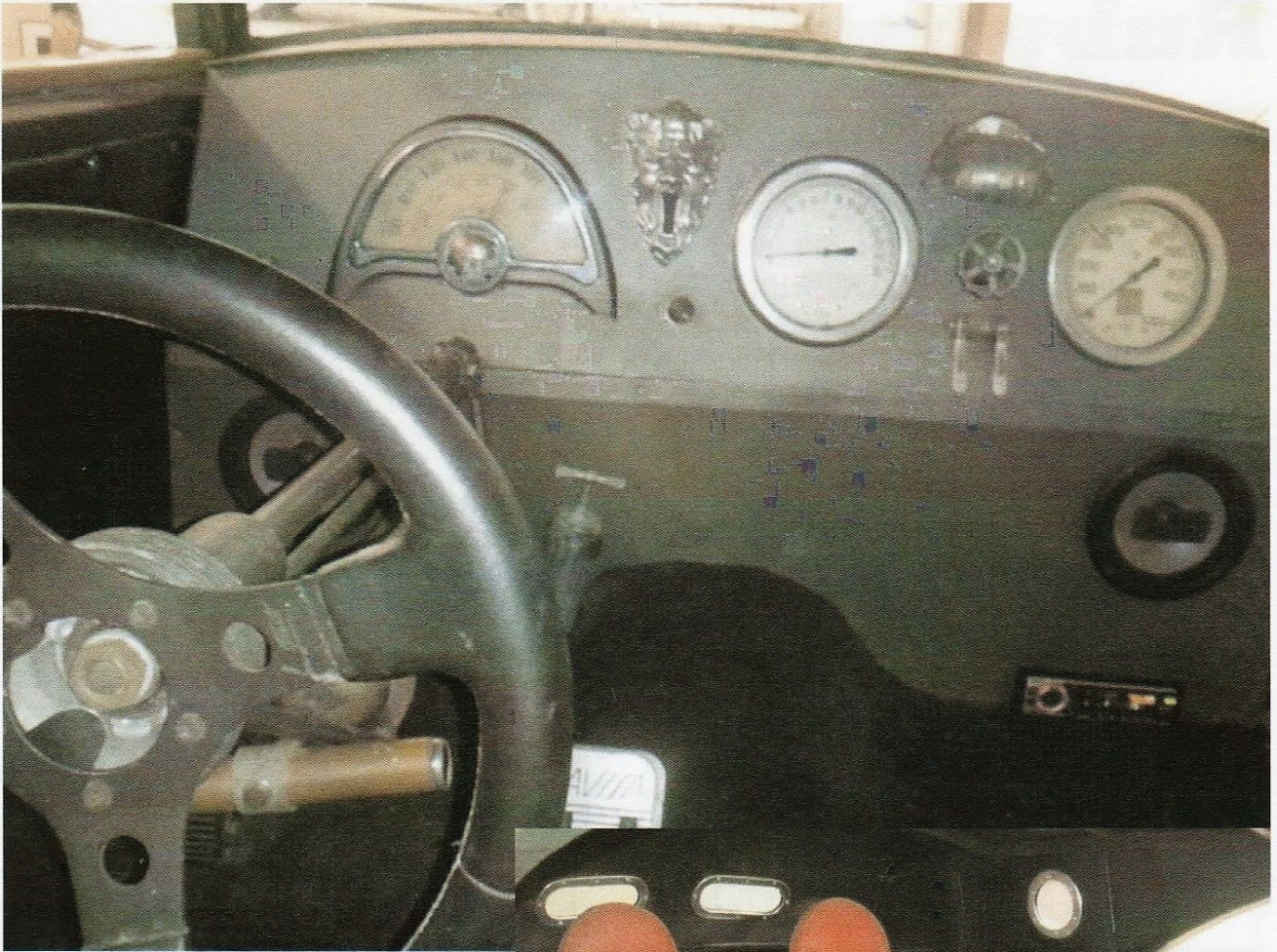

Ruby does not have side windows in the doors. The interior has red bucket seats, black carpet and a dashboard that makes Ruby extra special. The red exterior colour is red primer and Ruby has definitely developed a nice patina over the years!

Ruby starts, runs and is driveable. There is a car stereo installed but I cannot confirm it works. It appears — I'm not for sure and cannot prove it — that Ruby started out as a 1953 Triumph Mayflower and was built/modified into what she is today. Title in hand but the registration expired in 2003.

Be the proud new owner of Ruby! The highest bidder — once reserve is met — will be able to give her a new home.

Bid with confidence — buyer is required to have a Paypal account — bidders with (0) feedback: please contact me prior to bidding.



New French member

Hello

My name is Eric Sallefranque, I live in France near Bordeaux: 13 rue Edouard Branly, Apartment 39, 33110 Le Bouscat. My e-mail is eric8-4@hotmail.fr

I have just bought a 1951 Triumph Mayflower and would like to join your club for advice and parts.

Would you kindly send me a membership form and details.

Thank you very much for your reply. It is with a great pleasure that I join your club. As you offered me, I prefer to pay the joining fee in Euros. So, can I send you a mandate of 40 euros (which I think is about 35 pounds)?

I apologise for my approximate spelling but I don't speak English very well. I use the translator on my computer. So I'm afraid of making mistakes. Please forgive me again.

Currently, my Mayflower is located in Saint-Vivien de Médoc, where I own a house. This is where I hope to restore it. I send you some pictures. Therefore, at first, I need a technical



manual written in French if it's possible. Can you help me to get one? Thank you for the help and advice you can give me. I hope I hear from you soon.

Sincerely, Eric Sallefranque

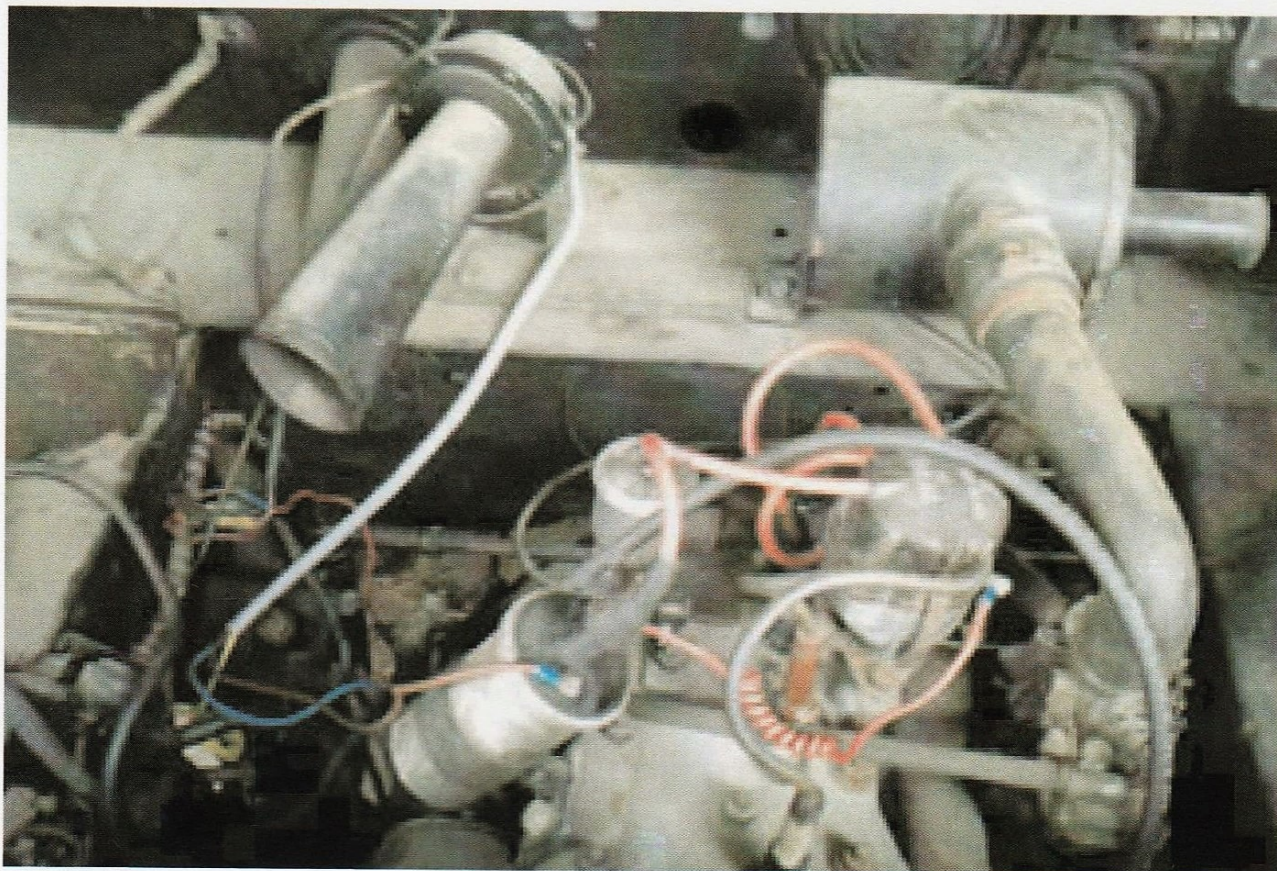

Is there a dipstick in your rear end?

by Russ Hoenig

WHILE LOOKING up the part number for a new red fibre washer for the rear end filler plug for TT20192, I noticed that the spare parts lists calls 56912 "washer for the plug".

In the service manual, the same part number is called "washer for the dipstick"!

This is call for further investigation as the spare parts list diagram shows the rear end filler plug drawn with a little "dipstick" to measure rear end fluid. What a novel idea, I had always thought you fill to the bottom of the threads but here is an exact measuring devise.

If there is supposed to be a dipstick in the rear end, TT20192 is going to get one, if it needs it or not!

TT6215's rear axle is out in the old horse barn, so a trip out there with a 9/16 wrench and lo and behold, the plugs are different. The plug from TT6215 shows the remnants of a stem that passed through the threaded plug body.

This stem appears to have been ground off flush with the length of the threaded area of the plug. There are no burrs so it does not appear to have been sawn off. It was definitely longer at one time and probably as shown in the spare parts list.

TT20192's rear end filler plug was never drilled to accept any type of stem. The photographs show TT6215 on the left.

So, the questions are: does anyone have a car with an intact "rear end filler plug with a dipstick" and "what are the dipstick measurements", or "were they all slowly ground off by the rear end gears" and "when did the change eliminating them come about"?



Letters

International journeys ...

Dear Nico,

It has been a while since I wrote to *Flower Power* and thought it time that I did!

It has also been a while since I drove my Mayflower on a long run since I did Lands End to John 'O Groats in 2008 and so this summer I drove from Scunthorpe, England to Galway, Ireland and back.

If I get the time I'll try and write up my journey, how well my car behaved and what a wonderful reception we got everywhere we went.

Next June I am planning to drive to Nessonvaux, Belgium to visit the Imperia site where Mayflowers were made up from kits.visit and drive on the track, or at the very least walk it.

From Google I can see that half of the factory roof and test track still stand and I am hoping to visit and drive on the track, or at the very least walk it.

If anyone knows who owns the site or has any ideas on how I may find out can they please contact me. My e-mails and enquiries to companies listed in the area, via Google, have drawn a blank to date.

Can I ask that you please put an advert in *Flower Power* for a bonnet? I'm planning to drive to Madrid in 2014 and I want to fit ventilation louvers in a bonnet to assist with engine cooling.

I am also going to install a high efficiency radiator core and electric fan. If any members have undertaken this kind of upgrade I'd appreciate any advice or tips!

Keep up the good work!

*Many thanks, regards
Stephen Coulman*

WANTED

**Triumph Mayflower
Bonnet Lid**

Contact:

Stephen Coulman 01724 762061



**Out on
parade ...**

Dear Ed,

I spotted this lovely looking Mayflower at the Erewash Rally in July.

*Regards
Dave Gothard*

Well done Brian (Barker 810), nice to see our cars out and about. Ed

The Saga of Maggie Ma

by Dave Walton, Membership No. 1111, previously No. 14

MAY I START by saying I have been a bit of a Mayflower nut since the early 60s!! As an impoverished young family man in need of "smarter" transport I ditched the dog-eared 1951 Hillman Minx (heavily rotted) and invested in a very smart 10-year-old 1953 Mayflower, LEW 192, if anybody knows of her.

She really was a very presentable car at low cost as by then she was somewhat "old hat". She was not perfect, at one point, having tried all else, I drove her 10 miles with the cylinder head nuts slacked off until "BANG" it lifted! Pulled the nuts back down and drove home to machine the head and replace the gasket.

She did well over two years, even towing an 18 cwt caravan through Wales. I think perhaps she was even the first Mayflower to sprout a second set of rear light pods as flashing indicators (somebody will, I am sure, know better).

Disappeared

She disappeared when the urge for a more "street cred" mode of transport took control and a 1957 Hillman Minx replaced her.

On to the early 70s when the need for a Mayflower again coursed through the veins, this time I could afford an old car as a hobby, everyday transport being satisfied by the company rep mobile!

I figured six months and she would be on the road. Six years later she rolled out of the garage and back into the wide world as JBD 807. Immaculate she was not but she provided an enjoyable year or two trundling around locally until family issues forced her release.

On to 2009, ambling about on the Internet I fell upon a Mayflower Club rally photo. In the middle of a group sat JBD 807! The blood surged again and the search started!

LLV 606 had been, I was assured, slumbering in a falling down lean-to on the outskirts of Liverpool since 1964, who knows? She had no documentation and was in need of some serious TLC. Just sills I told myself!

Over the last 20 months I have laboured manfully, learning new skills (welding, painting,

interior fitting, etc) and spending many happy hours immersed in *Mayflower Ology!* She is no longer just black as she left the factory, having gained a rich cream centre section to match the 1950s BSA C12 that she will tow to local shows.

After much work she was ready for the MoT, she was not running well but an MoT is a prerequisite of the DVLA assigning a registration number so she headed for a pre-booked test.

She made it half way and stopped, naturally on a major traffic island at rush hour. Trying not to attract too much attention to this "unusual" old motor car, I nonchalantly leaned against the boot lid (to hide the lack of number plates) and called for a tow. My "ex" friends at the MoT station thought this hilarious.

After a blow through the fuel line with compressed air she trundled into the test and *PASSED!* Much relieved I started home, she boiled before we got there! However at least she could now be allocated a number 634 YUG!

As summer approached I targeted the 50s weekend at the Crich Tramway Village, a serious gathering of all things fifties. The plan was I would do the Saturday in my Metropolitan as usual but this time the Sunday would be reserved for Maggie! The best efforts of mice and men, she never made it!

A re-cored radiator later and investigation of the fuel problem highlighted the rust in the petrol tank.

Tank out, in, etc

Tank out, washed out with paraffin and stones tank in! No fuel at carb.

Tank out, steam cleaned, tank in, no fuel at carb.

Fuel line replaced from tank to carb, engine runs! Engine stops, no fuel!

Tank out, chemically cleaned, tank in, engine runs for five minutes, no fuel at carb!

Tank out, top cut off, internals bead blast clean, at last *NORUST!*

(Series 1 Mayflower)

seem to recall)



Tank welded up, back in, petrol over garage floor, tank now porous!

At this stage I am about to loose all interest in old motor cars!

Please note that the above sequence has been simplified for dramatic effect, normal tests and procedures were undertaken at each stage.

A similar saga relates to the poor running, which involved the usual dismantling and cleaning of carburettor, distributor rebuild, replacement capacitor, distributor cap and leads along with plugs and coil.

With summer all but gone I resolved to make our local clubs late run to the Catton Park do in early September. She made it (only 40 miles round trip) without petrol gauge and with a temporary 5-litre boot-mounted tank, vented to atmosphere of course!

Well that is the story so far, a new tank has been organised and will hopefully soon be fitted so she should soon be ambling around Derbyshire on the odd fine day.

Incidentally, if anyone should have any knowledge of LLV 606 I would appreciate any help in getting this original number back, DVLA will not consider this without documentary evidence.

**HAVE YOU GOT
ANYTHING TO SELL?**
or
DO YOU NEED SOMETHING?

Club members can place
advertisements in *Flower Power*
absolutely FREE

Australian Mayflower

Dear John,

I have enclosed a couple of photographs of my Mayflower. I live on Woodford Island in the River Clarence on the north coast of New South Wales and the south arm of the river is in the background.

Regards Ted Newbery
271 South Arm School Road
NSW 2460, Australia

WANTED Mayflower Fuel Filler Cap

Please contact:
Steve Watts at
01759 373383
or e-mail gingersjw@hotmail.com



Letters**Trafficators in a flash!**

Dear members,

Soooo you wanna have your turn lights flash AND still have the traficators work, well so did I and here is how I did it!

First as you know the turn indicator switch is just above the horn button. Coming to the turn switch in the steering column are three wires. One is power from the dash (my wire diagram from the Mayflower manual indicates it to be green). The trafficator leads were: 'right' — green with white and 'left' was green with red.

If your wires no longer have the colour code here is a suggestion — first locate the wires coming out of the steering column in the engine compartment.

One will be the power to the horn and turn signals. The "trafficator" or turn signal is a solenoid and requires a steady 12 volts to work. If wired through a flasher unit the arm will only jump and will not stay activated.

To determine which wire you will need:

- 1) Use a straight pin attached to a wire and an ohm meter. See picture.
- 2) + or - ground will not matter to the trafficator.
- 3) Ground the other side of the ohm meter (should register 12 volts).
- 4) Turn the ignition on.
- 5) Insert the pin into one of the wires.

a) If the meter does not register you're lucky, you may have discovered one of the turn indicator leads (green with white, or green with red) — activate one of the trafficators, if nothing try the other side. If still nothing have someone toot the horn (black). One of the wires should have caused the meter to register (see c).

b) You now have one of the wires identified. Label it with masking tape.

c) Now go to the next wire. If the meter indicates you have found one of the power leads either the horn or the turn signal power supply — it won't matter, just mark it "hot".

d) Now on to the next until you have all the wires identified.

e) If you didn't stick your finger at least once you did better than me!

You will have to change the parking light bulb socket on each front fender. Replace it with one from an MGA, TR-4, Austin or anything that had a turn flasher as it will have two contacts one for parking and one for flashers.

The three screws holding the socket base should match the ones from your Mayflower. You will have to run the new wire to the flasher unit (again, see the attached diagram).

I could not modify the rear tail light, so I added the bar with two lights one on each side of license plate. I have added a picture and again see the attached diagram.

Now comes the fun part

The flasher units are Wagner No. 552 — 12 volt from Auto Zone or any parts store and I made the holder from a small piece of angle aluminum.

Again look at the picture — hold your breath and cut one of the wires going to one of the trafficators (if you are lucky there may be a push connector).

Replace it with a two way push connector socket and use one outlet to run a new wire to the "new to be" flasher unit).

The existing wire will run to the trafficator (and now it should work). The new wire as mentioned goes to one of the flashers — from that flasher run two wires, one wire running to the front fender (preferably the same side as the trafficator) and the other wire to the rear tail light on the license plate.

Now do the same thing for the other trafficator wire.

When activated, the hot lead will continue to activate the solenoid and the branch wire to the flasher will cause the turn lights to flash. I'm not sure if the new LED lights will produce enough resistance to cause the flasher to flash.

In addition just for safety measure I also hooked up a lead from the brake light on one side to a Cyclops light in the rear window. Found the Cyclops light in the same place I bought the flashers.

If you get lost my e-mail is lelandfelix@yahoo.com

Leland Felix
124 Leigh Circle, Hot Springs
Arkansas, 71901 USA

TRIUMPH MAYFLOW WIRING DIAGRAM

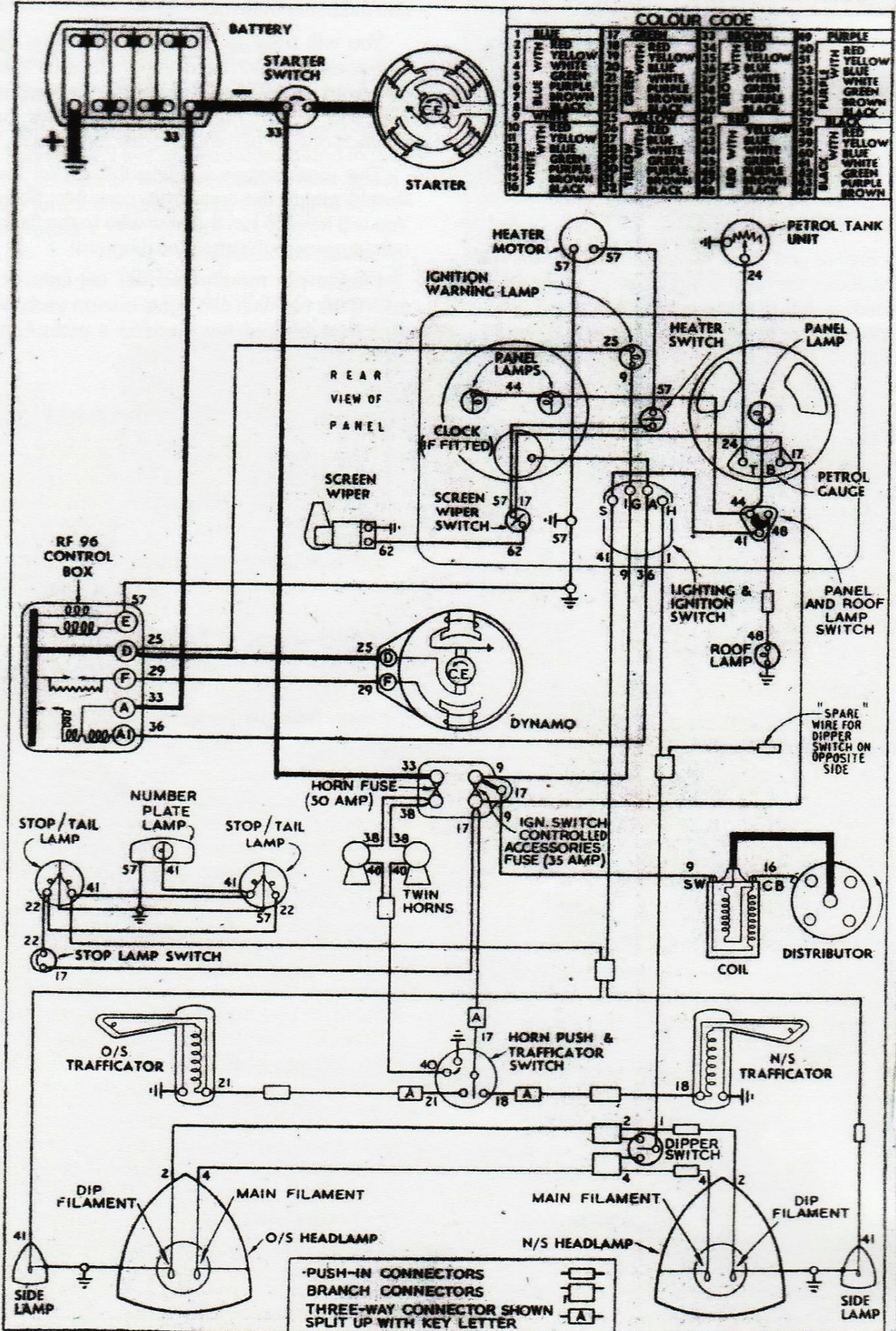

FLOWER POWER

1/2" X 1/2"
Angle Aluminum
To hold the
Flashers in place

10X 32 Screw

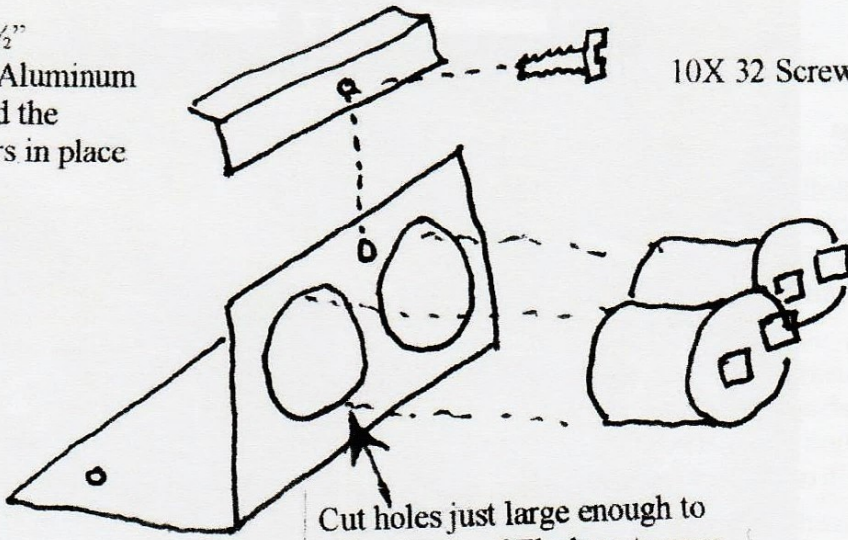

2" X 2" Angle
Aluminum

Cut holes just large enough to
Allow body of Flashers to pass
Thru. The lip of the flasher
Will rest against the bracket.

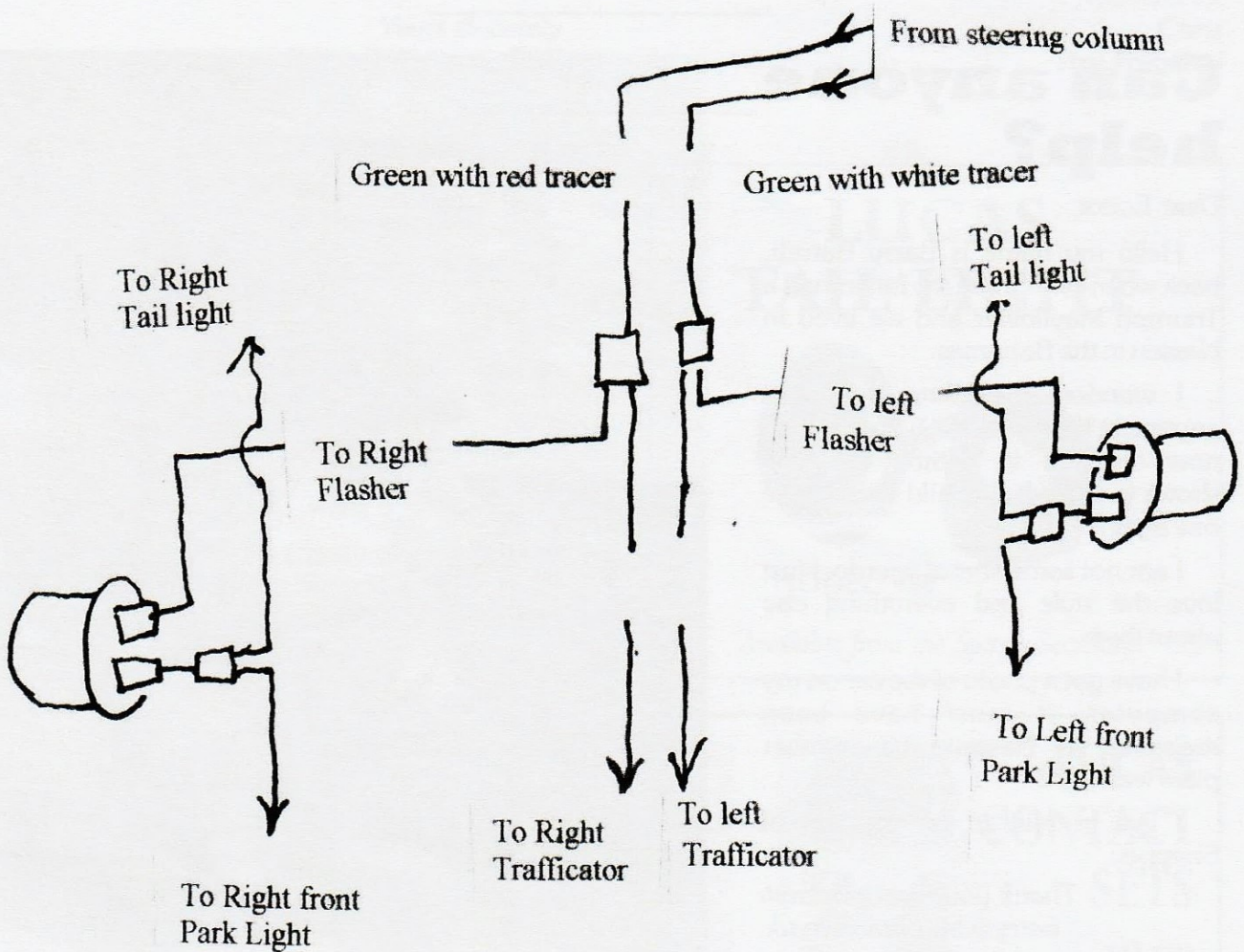

Letters

New member from Essex

Dear John (Oaker),

I have attached the completed membership application form together with a photograph of my car in its new home.

*Many thanks
Ian Sisterson
Burnham on Crouch
Essex*



Can anyone help?

Dear Editor,

Hello my name is Barry Barrett, back when I was three my father had a Triumph Mayflower and we lived in Nassau in the Bahamas.

I wondered whether there was anyone in Kent who still has one. I am now disabled so getting to some shows is difficult. I would love to see one again.

I am not some sort of wierdo, I just love the style and everything else about them.

I have got a photo of the car on my computer, it must have been registered in Nassau, the number plate was 1492.

I live in Minster on the Isle of Sheppey.

*Thank you, Barry Barrett,
barry@bb-photos.co.uk*

If anyone can help please contact John Oaker — Ed

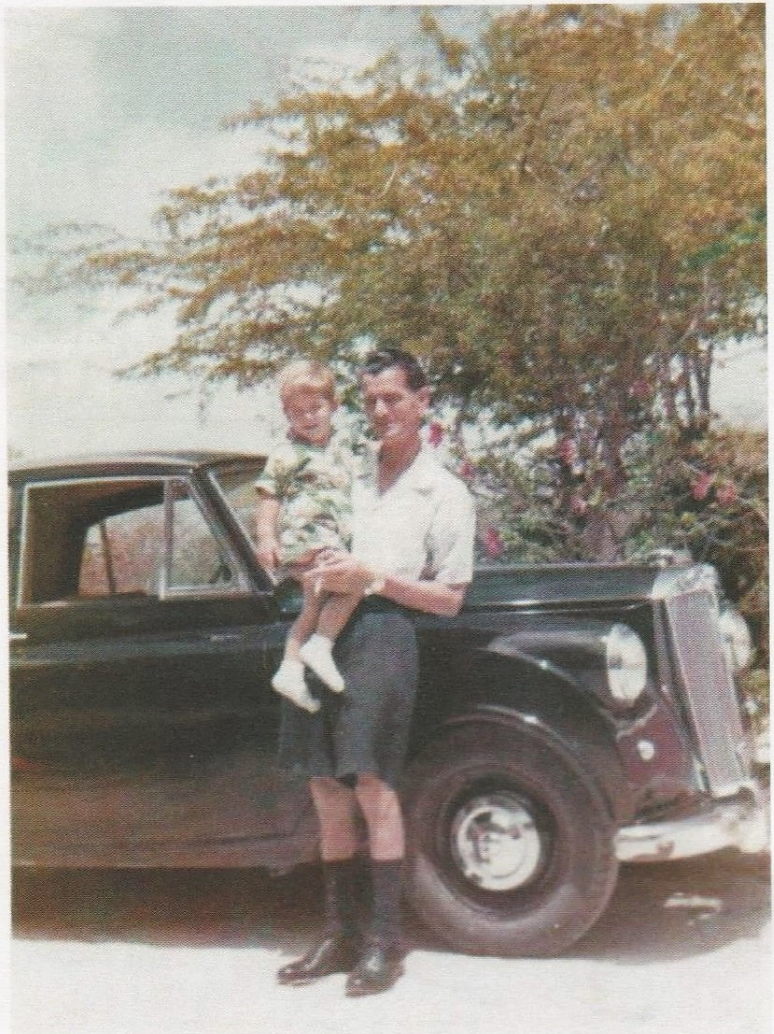

Success at Knebworth

Dear Nico

I am now able to advise you relative to the recent success of my Triumph Mayflower at Knebworth House at the Classic Car event organized by Greenwood Exhibitions over the 2011 August bank holiday.

My 1952 Triumph Mayflower, registration number PMV 97, was voted Concours 2011 Class Winner which goes to prove that there is something special about the Mayflower.

My car created a great deal of attention, some loving it and some not loving it, but at the end of the day it was the only one of its kind there and it proved to be the best out of approximately 200 cars.

To all the members of the Triumph Mayflower Club this should be an encouragement and prove that it is a beautiful car and, for the most part, very much admired.

Yours sincerely
Brian B Winston, OBE

May we help?

Hello,

I saw your website and thought i'd drop you a line.

We are a company based in Bury St Edmunds in Suffolk who specialise in brake and clutch restoration for the older vehicles and thought you might benefit from having us as a contact for those hard to find spare parts.

We can sleeve any hydraulic cylinder in stainless steel to restore the bore and new seals are fitted as standard. You can expect your cylinder to come back looking like new with one years warranty on it!

Usually our turn around time is about a week from receipt but due to seasonal changes this can vary.

Our website address is www.pastparts.co.uk and restore@pastparts.co.uk is our e-mail address. if you have any further questions, please do contact us!

Thanks a lot
Chris
Past Parts Ltd

Rally news

by John Castle, Rally Secretary

THE 2012 RALLY will be held on Sunday, July 15, at Broughton Castle, Banbury in conjunction with the Triumph Renown Club.

It has yet to be confirmed with Broughton Castle but let's have as many cars as possible please, let's try for a big turn out,

If anyone would like to stay over night near or have a meal as a club on the Saturday night then drive to the rally Sunday morning all together please let me know I will sort it out.

LUCAS TAIL LIGHT

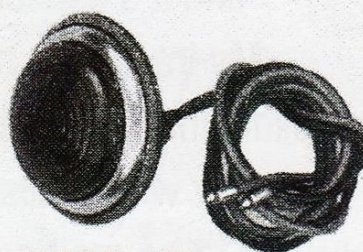

MODEL 488

Available from the Spares Secretary

NUMBER PLATE LIGHT

ONLY £22.00 EACH

From the Spares Secretary

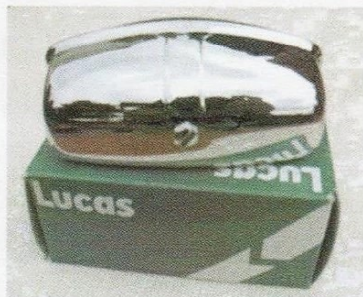

LUCAS CONTACT SETS

£9.00

EACH



If My Body Was a Car

(This is scary, how true it is!!)

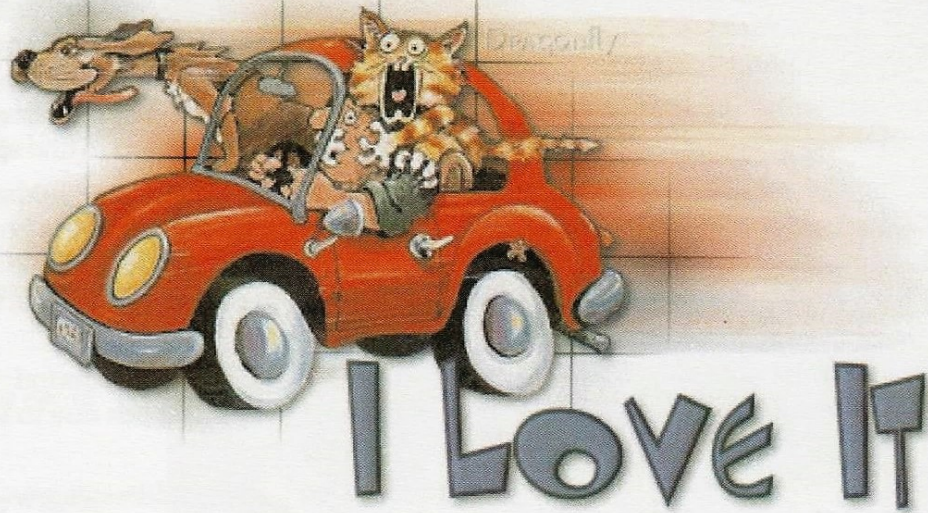

If my body was a car

This is the time I would be thinking about trading it in for a newer model.

I've got bumps and dents and scratches in my finish
and my paint job is getting a little dull ...

But that's not the worst of it.

My headlights are out of focus
and it's especially hard to see things up close.

My traction is not as graceful as it once was . . .

I slip and slide and skid and bump into things even in the best of weather.

My whitewalls are stained with varicose veins.

It takes me hours to reach my maximum speed.

My fuel rate burns inefficiently.

But here's the worst of it . . .

Almost every time I sneeze,
cough or sputter,
either my radiator leaks
or my exhaust backfires!



Classic Car Sills

Parts for the Triumph Mayflower

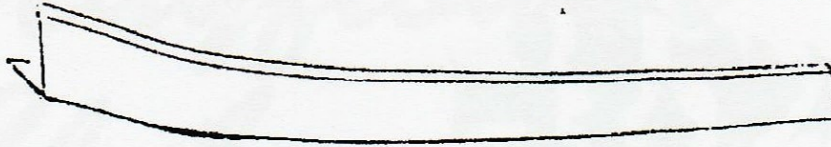

SILL £25.00

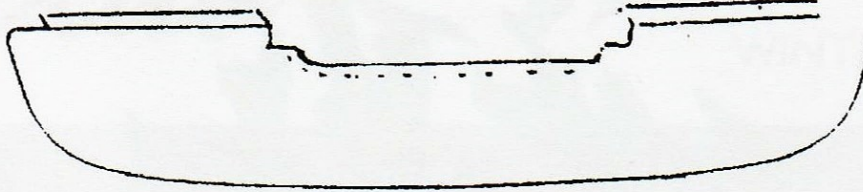

FRONT
APRON £48.00

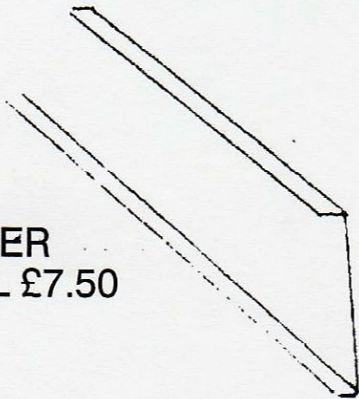

INNER
SILL £7.50

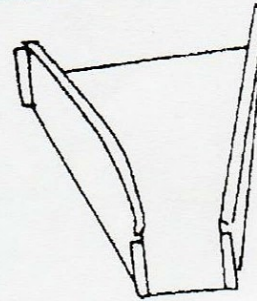

OUTRIGGER
£10.00

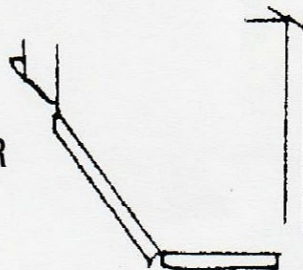

REAR SPRING
CHASSIS
£7.50

OUTRIGGER
£10.00

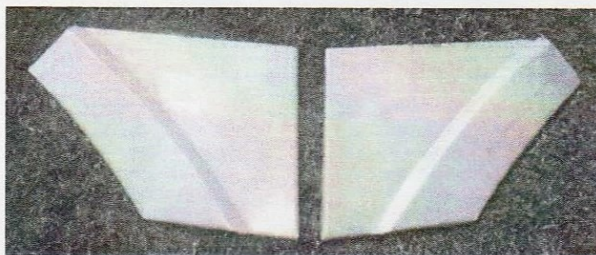
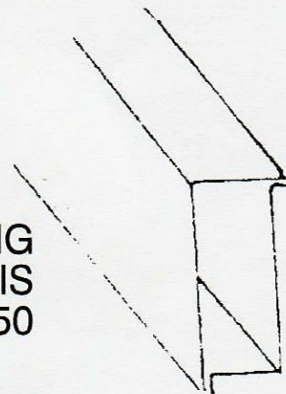

BOTTOM FRONT WING PATCHES £15.00



FRONT WHEEL
ARCH SPLASH
PANEL
£5.00

*Prices at 2008

J. COLLIER

4 Mortimer Road, Kempston, Bedford MK42 8RE
Tel: 01234 840958 (Evenings) or 01480 477530 (Works)

Season's Greetings



from all the Club Officers

The Saga of Maggie May (Series 1 Mayflower)

by Dave Walton, Membership No. 1111, previously No. 14 (seem to recall)

MAY I START by saying I have been a bit of a Mayflower nut since the early 60s!! As an impoverished young family man in need of "smarter" transport I ditched the dog-eared 1951 Hillman Minx (heavily rotted) and invested in a very smart 10-year-old 1953 Mayflower, LEW 192, if anybody knows of her.

She really was a very presentable car at low cost as by then she was somewhat "old hat". She was not perfect, at one point, having tried all else, I drove her 10 miles with the cylinder head nuts slacked off until "BANG" it lifted! Pulled the nuts back down and drove home to machine the head and replace the gasket.

She did well over two years, even towing an 18 cwt caravan through Wales. I think perhaps she was even the first Mayflower to sprout a second set of rear light pods as flashing indicators (somebody will, I am sure, know better).

Disappeared

She disappeared when the urge for a more "street cred" mode of transport took control and a 1957 Hillman Minx replaced her.

On to the early 70s when the need for a Mayflower again coursed through the veins, this time I could afford an old car as a hobby, everyday transport being satisfied by the company rep mobile!

I figured six months and she would be on the road. Six years later she rolled out of the garage and back into the wide world as JBD 807. Immaculate she was not but she provided an enjoyable year or two trundling around locally until family issues forced her release.

On to 2009, ambling about on the internet I fell upon a Mayflower Club rally photo. In the middle of a group sat JBD 807! The blood surged again and the search started!

LLV 606 had been, I was assured, slumbering in a falling down lean-to on the outskirts of Liverpool since 1964, who knows? She had no documentation and was in need of some serious TLC. Just silks I told myself!

Over the last 20 months I have laboured manfully, learning new skills (welding, painting,

interior fitting, etc) and spending many happy hours immersed in *Mayflower Ology!* She is no longer just black as she left the factory, having gained a rich cream centre section to match the 1950s BSA C12 that she will tow to local shows.

After much work she was ready for the MoT, she was not running well but an MoT is a prerequisite of the DVLA assigning a registration number so she headed for a pre-booked test.

She made it half way and stopped, naturally on a major traffic island at rush hour. Trying not to attract too much attention to this "unusual" old motor car, I nonchalantly leaned against the boot lid (to hide the lack of number plates) and called for a tow. My "ex" friends at the MoT station thought this hilarious.

After a blow through the fuel line with compressed air she trundled into the test and PASSED! Much relieved I started home, she boiled before we got there! However at least she could now be allocated a number 634 YUG!

As summer approached I targeted the 50s weekend at the Crich Tramway Village, a serious gathering of all things fifties. The plan was I would do the Saturday in my Metropolitan as usual but this time the Sunday would be reserved for Maggie! The best efforts of nice and men, she never made it!

Are-cored radiator later and investigation of the fuel problem highlighted the rust in the petrol tank.

Tank out, In, etc

Tank out, washed out with paraffin and stone tank in! No fuel at carb.

Tank out, steam cleaned, tank in, no fuel at carb.

Fuel line replaced from tank to carb, engine runs! Engine stops, no fuel!

Tank out, chemically cleaned, tank in, engine runs for five minutes, no fuel at carb!

Tank out, top cut off, internals bead blast clean, at last! *NORUST!*



Tank welded up, back in, petrol over garage floor, tank now porous!

At this stage I am about to loose all interest in old motor cars!

Please note that the above sequence has been simplified for dramatic effect, normal tests and procedures were undertaken at each stage.

A similar saga relates to the poor running, which involved the usual dismantling and cleaning of carburettor, distributor rebuild, replacement capacitor, distributor cap and leads along with plugs and coil.

With summer all but gone I resolved to make our local clubs late run to the Catton Park do in early September. She made it (only 40 miles round trip) without petrol gauge and with a temporary 5-litre boot-mounted tank, vented to atmosphere of course!

Well that is the story so far, a new tank has been organised and will hopefully soon be fitted so she should soon be ambling around Derbyshire on the odd fine day.

Incidentally, if anyone should have any knowledge of LLV 606 I would appreciate any help in getting this original number back, DVLA will not consider this without documentary evidence.

HAVE YOU GOT
ANYTHING TO SELL?

OR

DO YOU NEED SOMETHING?

Club members can place
advertisements in *Flower Power*
absolutely FREE